

MANUAL
OWNER'S

Instructions and warnings **IE**
Installer and
Maintenance technician

1.044631ENG



AUDAX PRO 4 - 6 - 9 V2

Outdoor
Condensing
Unit



INDEX

Dear Customer,.....	3	8	Installation of chiller lines.	28	
General warnings	4	8.1	Allowed length of the refrigerant pipe and installation examples.	28	
Safety symbols used.....	6	8.2	Selection of refrigerant pipe.	29	
Personal protective equipment.	6	8.3	Keep the refrigerant pipe clean and dry.....	29	
1	Product specifications.	7	8.4	Cutting and flanging of pipes.....	30
1.1	Product range.....	7	8.5	Choose the insulation of the refrigerant pipe.	32
1.2	Accessories.....	7	8.6	Insulating the refrigerant pipe.	32
2	Outdoor unit specifications.	8	8.7	Braze welding the pipe.	32
3	Main components.	9	8.8	Testing for refrigerant gas leaks.	33
4	Installation of the unit.....	10	8.9	Creating vacuum.....	34
4.1	Outdoor unit installation position.	10	8.10	Select the additional refrigerant charge.	35
4.2	Installation guide near the sea.	10	8.11	Recharging the refrigerant.....	35
4.3	Preparation of fire extinguisher.	12	8.12	Adding refrigerant.	37
4.4	Free ignition sources.	12	8.13	Closing the valve stem.....	38
4.5	Ventilation of the area.	12	8.14	Opening the valve stem.....	38
4.6	Leak detection methods.....	12	9	Cooling cycle diagrams.....	39
4.7	Labelling.....	12	9.1	Audax Pro 4-6 V2 diagram.....	39
4.8	Recovery.....	13	9.2	Audax Pro 9 V2 diagram.	39
4.9	Installation place requirements.....	13	10	Wiring diagrams.	40
4.10	Moving the outdoor unit with wire ropes.	13	10.1	Audax Pro 4-6 V2 wiring diagram.	40
4.11	Clearance requirements for the outdoor unit.	14	10.2	Audax Pro 9 V2 wiring diagram.....	41
4.12	Installing the outdoor unit.	16	11	Microswitch and key function settings.	42
4.13	Mount of outdoor unit.	16	11.1	Audax Pro 4-6 V2 testing operations.....	42
4.14	Drain.....	17	11.2	Audax Pro 9 V2 testing operations.....	44
4.15	Positioning the unit in a rigid climate.....	19	12	“Pump down” execution.....	47
5	Electrical connections.	20	12.1	Purpose of “Pump down”.....	47
5.1	General configuration of the system.	20	12.2	Important warnings for “Pump down” execution.....	47
6	Connection of the cable.....	21	12.3	Collect the refrigerant in a specific vessel before “Pump down”.....	48
6.1	Power cable specifications.	21	13	Completion of installation.....	49
6.2	Specifications of connecting cables.	21	14	Final inspections and test operation.	50
6.3	Specifications of single phase terminal block.	21	14.1	Inspection prior to test operation.....	50
6.4	Power cable connection diagram.....	22	14.2	Test operation.....	50
6.5	Connection of power terminal.....	24			
6.6	Installation of earthing wire.	24			
6.7	How to connect extension cables.....	25			
7	Checking correct earthing.....	27			

Dear Customer,

Congratulations for having chosen a top-quality Immergas product, able to assure well-being and safety for a long period of time. As an Immergas Customer, you can also count on a qualified after-sales service, prepared and updated to guarantee constant efficiency of your heat pump. Read the following pages carefully: you will be able to draw useful tips on the proper use of the device, compliance with which will confirm your satisfaction with the Immergas product.

For assistance and routine maintenance, contact Authorised Service Centres: they have original spare parts and are specifically trained directly by the manufacturer.

The company **IMMERGAS S.p.A.**, with registered office in via Cisa Ligure 95 42041 Brescello (RE), declares that the design, manufacturing and after-sales assistance processes comply with the requirements of standard **UNI EN ISO 9001:2015**.

For further details on the product CE marking, request a copy of the Declaration of Conformity from the manufacturer, specifying the appliance model and the language of the country.

The manufacturer declines all liability due to printing or transcription errors, reserving the right to make any modifications to its technical and commercial documents without forewarning.



Correct disposal of the product

(Waste electrical and electronic equipment)(Applicable in Countries with separate waste collection systems)

When this symbol is applied on the product, on the accessories or on its documentation, it means that the product and relative electronic accessories must not be disposed of with other waste at the end of its life cycle. To avoid damaging the environment or health due to incorrect waste disposal, the user is recommended to separate the product and the above-mentioned accessories from other types of waste and to recycle them responsibly by sending them to authorised facilities in compliance with local standards.

Household users are encouraged to contact the dealer where they purchased the product or the competent authorities to receive all of the information regarding the separate waste collection of these products so that they may be disposed of properly without harming the environment.

Corporate users should contact their supplier and verify the terms and conditions of the purchase contract. This product and relative electronic accessories must not be disposed of together with other commercial waste.

GENERAL WARNINGS

- Carefully follow the precautions listed below as they are crucial to guarantee the safety of the product.

ATTENTION:

- **always disconnect power to the condensing unit before performing maintenance on it or accessing the components inside the unit.**
- **Make sure that installation and inspection operations are carried out by qualified personnel.**
- **They must comply with the precautions and other important warnings to avoid seriously damaging the system and injuring the users.**



- Carefully read the content of this manual before installing the condensing unit and keep it in a safe place so that it can be referred to after installation.
- For greater safety, the installers should always read the following warnings with the utmost attention.
- Store the use and maintenance manual in a safe place and remember to hand it over to the new owner should the condensing unit be sold or transferred.
- This manual explains how to install the condensing unit. Using other types of units with different control systems can damage the units and invalidate the warranty. The manufacturer will not be held liable for damage resulting from improper use of the unit.
- The manufacturer cannot be held liable for damage resulting from unauthorised changes or improper connection of the electric and hydraulic lines. Failure to comply with these instructions or with the requirements set forth in the “Operating limits” table, including those in the manual, immediately invalidates the warranty.
- Failure to comply with the instructions indicated in the production specifications immediately invalidates the warranty.
- Do not use the units if you notice any damage on them or if you perceive something strange, such as a loud noise or burnt smell.
- To prevent electrocution, fire or injury, always switch off the unit, disable the protective switch and, if smoke escapes or if the unit is extremely noisy, contact the Authorised Technical Service Centre.
- Remember to inspect the unit at regular intervals, including the electrical connections, the refrigerant pipes and the protections.
- These operations must only be done by qualified personnel.
- The unit contains moving and electric parts which must always be kept out of the reach of children.
- Do not have unauthorised personnel attempt to repair, move, modify or reinstall the unit. These operations could cause damage to the product, electric shocks and fire.
- Do not place liquid containers or other objects on the unit.
- All the materials used to manufacture and package the condensing unit are recyclable.
- The packaging material and the dead batteries of the remote control (optional) must be disposed of in compliance with local standards.
- The refrigerant in the condensing unit must be disposed of as special waste. At the end of its life, the condensing unit must be disposed of in an Authorised Assistance Centre or returned to the shop so that it can be disposed of correctly and safely.
- Wear protective gloves to unpack, move, install and repair the unit so that its edges do not injure your hands.
- Do not touch the internal parts (water pipes, refrigerant pipes, heat exchanger, etc.) while the unit is operating. If it needs to be adjusted, leave it as long as necessary to cool off and make sure to put on protective gloves.
- In case of refrigerant leaks, try not to come into contact with the refrigerant as this could cause serious injury.
- If the condensing unit is installed in a small room, consider adequate ventilation to avoid a leak level beyond the maximum allowed limit. In that case, there is the risk of death by suffocation.

- Make sure to dispose of the packaging materials safely. The packaging items, such as nails and other metals or wooden pallets can cause injuries to children.
- Inspect the shipped product and make sure it was not damaged during transport. If you notice any damage, **DO NOT INSTALL THE PRODUCT** and immediately report any damage to the carrier or dealer (if the installer or authorised technician withdrew the material from the dealer).
- Our units must be installed according to the clearance spaces described in the installation manual so that both sides are accessible and to allow for repairs and maintenance to be performed. If the units are installed without complying with the procedures described in the manual, additional costs could be required since special wiring, ladders, scaffolds or any other elevation system for repairs are **NOT** considered covered by the warranty and are therefore charged to the end customer.
- Always make sure that the power supply complies with local safety standards.
- Check that the supply voltage and frequency comply with the specifications and that there is sufficient input power to guarantee operation of any other household appliance connected to the same power lines. Always make sure that the on-off switches and circuit breakers are selected appropriately.
- Always check that the electrical connections (cable inlet, wire cross-section, protections, etc.) comply with the electrical specifications and with the instructions in the wiring diagram. Always check that all of the connections comply with the regulations applicable to installation of the heat pumps. The devices not connected to the power supply must be completely disconnected according to the conditions envisaged by the overvoltage categories.
- Do not connect the earth wire to the gas piping, to the water piping, to the lightning rod, to the overvoltage absorber or to the telephone cable. An electric shock or a fire could occur if earthing is not complete.
- Make sure to install both the earth leakage detector and the circuit switch of the capacity specified in compliance with local and national standards in force. If they are not installed properly, they can cause electric shocks and fires.
- Make sure that condensate exits properly from the unit at low room temperature. Do not allow frost or ice to form on the drain pipe or on the heater. If the drain is not done properly for release of condensate, the units could be damaged by ice blocks and the system could be stopped, covered with ice.
- Install the power cable and the communication cable between the indoor and outdoor unit at least 1 m from the household appliance.
- Protect the appliance against mice or small animals. If an animal creates a contact with electric parts, it could cause malfunctioning, smoke or fires. Inform the customer to keep the area around the unit clean.
- Do not disassemble or modify the heater on your own initiative.
- This appliance is not intended to be used by persons (including children) with reduced physical, sensory or mental capabilities or lacking experience and the necessary knowledge, unless they are supervised or trained on use of the appliance by someone in charge of their safety. Children must be supervised to make sure they do not play with the appliance.
- For use in Europe: this appliance may be used by children at least 8 years old or by persons with reduced physical, sensory or mental capabilities or lacking experience and basic notions, as long as they are supervised or properly trained on safe use of the appliance and are aware of the risks posed by it. Do not allow children to play with the appliance. The appliance must not be cleaned and serviced by children without the supervision of an adult.
- Make sure not to modify the power cable, to make extensions or connections with several wires.
- This could cause electrocutions or fire due to connections or insulation made improperly or exceeding the current limit. If extensions need to be made due to damage along the power line, see chapter “How to connect extension cables” in the installation manual.
- Do not use means to speed up the defrosting operation or to clean other than those recommended by Immergas.
- Do not puncture or burn.
- Be aware that refrigerants are odourless.

SAFETY SYMBOLS USED.



GENERIC HAZARD

Strictly follow all of the indications next to the pictogram. Failure to follow the indications can generate hazard situations resulting in possible harm to the health of the operator and user in general.



ELECTRICAL HAZARD

Strictly follow all of the indications next to the pictogram. The symbol indicates the appliance's electrical components or, in this manual, identifies actions that can cause an electrical hazard.



LOW FLAMMABILITY MATERIAL

The symbol indicates that the appliance contains low flammability material.



WARNING FOR INSTALLER

Read the instruction booklet carefully before installing the product.



NOTE FOR INSTALLER

Indicates useful tips or additional information for the installer.



WARNING FOR USER

Read the instruction booklet carefully before using the product.



READ AND UNDERSTAND THE INSTRUCTIONS

Read and understand the appliance's instructions before performing any operation, carefully following the indications provided.



INFORMATION

Indicates useful tips or additional information in general.



The user must not dispose of the appliance at the end of its service life as municipal waste, but send it to appropriate collection centres.

PERSONAL PROTECTIVE EQUIPMENT.



SAFETY GLOVES



SAFETY GOGGLES



SAFETY FOOTWEAR

1 PRODUCT SPECIFICATIONS.

1.1 PRODUCT RANGE.

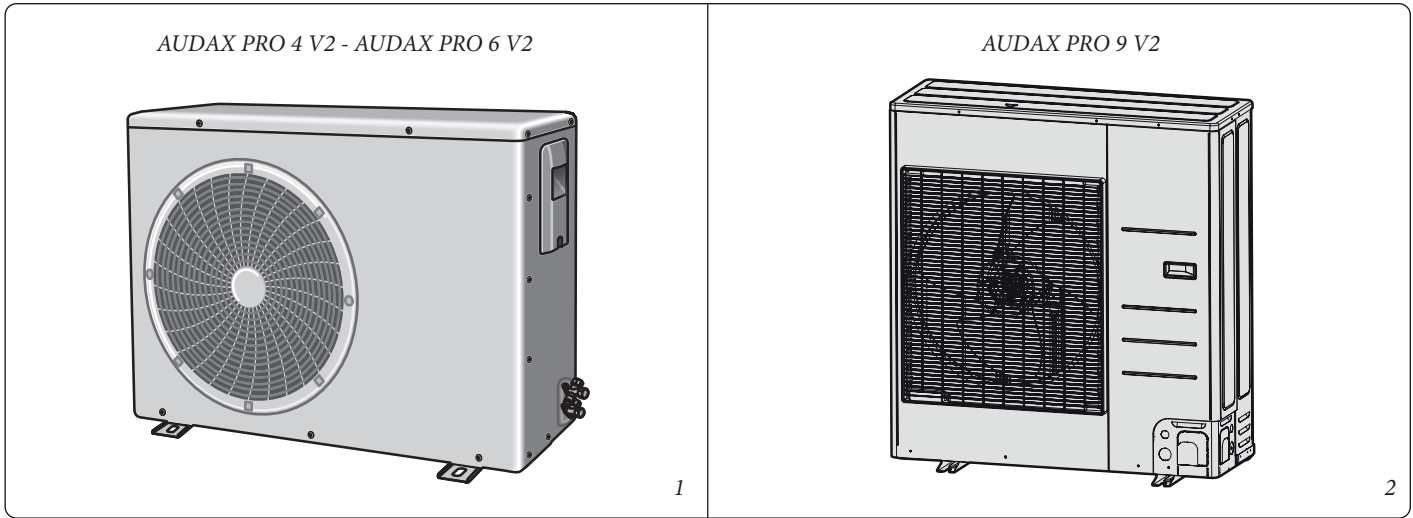



1.2 ACCESSORIES.

Keep the supplied accessories at hand until installation is finished.

Give the installation manual to the customer at the end of installation. The amounts are indicated in brackets.

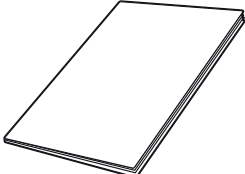
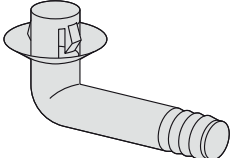
The outdoor condensing unit of the basic heat pump for interiors works according to the outside climate.

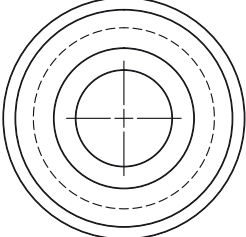
Installation manual (1)	Drain plug (2)	Rubber feet (4)	Drain plug (3)
			

2 OUTDOOR UNIT SPECIFICATIONS.

Type	Unit	Audax Pro 4 V2	Audax Pro 6 V2	Audax Pro 9 V2
Power supply	-	1P, 220~240 VAC, 50 Hz		
Compressor	-	Twin Rotary		
Oil compressor	-	POE		
Fan - Unit number		1		
Fan - Air flow	CMM	40	43	66
Refrigerant load	Kg	1.2		1.4
Type of refrigerant		R32		
Refrigerant control method		EEV		
Chiller line section - liquid phase	ø	1/4"		
Chiller line section - gaseous phase	ø	5/8"		
Sound pressure level (central heating / cooling)	dB(A)	44 / 46	47 / 47	49 / 49
Sound power level (central heating / cooling)	dB(A)	58 / 61	60 / 62	64 / 63
Operating field (central heating / cooling)	°C	-25~35/10~46		
Weight (net / gross)	kg	46.5 / 49.5		73.0 / 81.5
Dimensions (L x H x D, overall clearance)	mm	880 x 638 x 310		940 x 998 x 330

3 MAIN COMPONENTS.

General dimensions in mm Audax Pro 4-6 V2

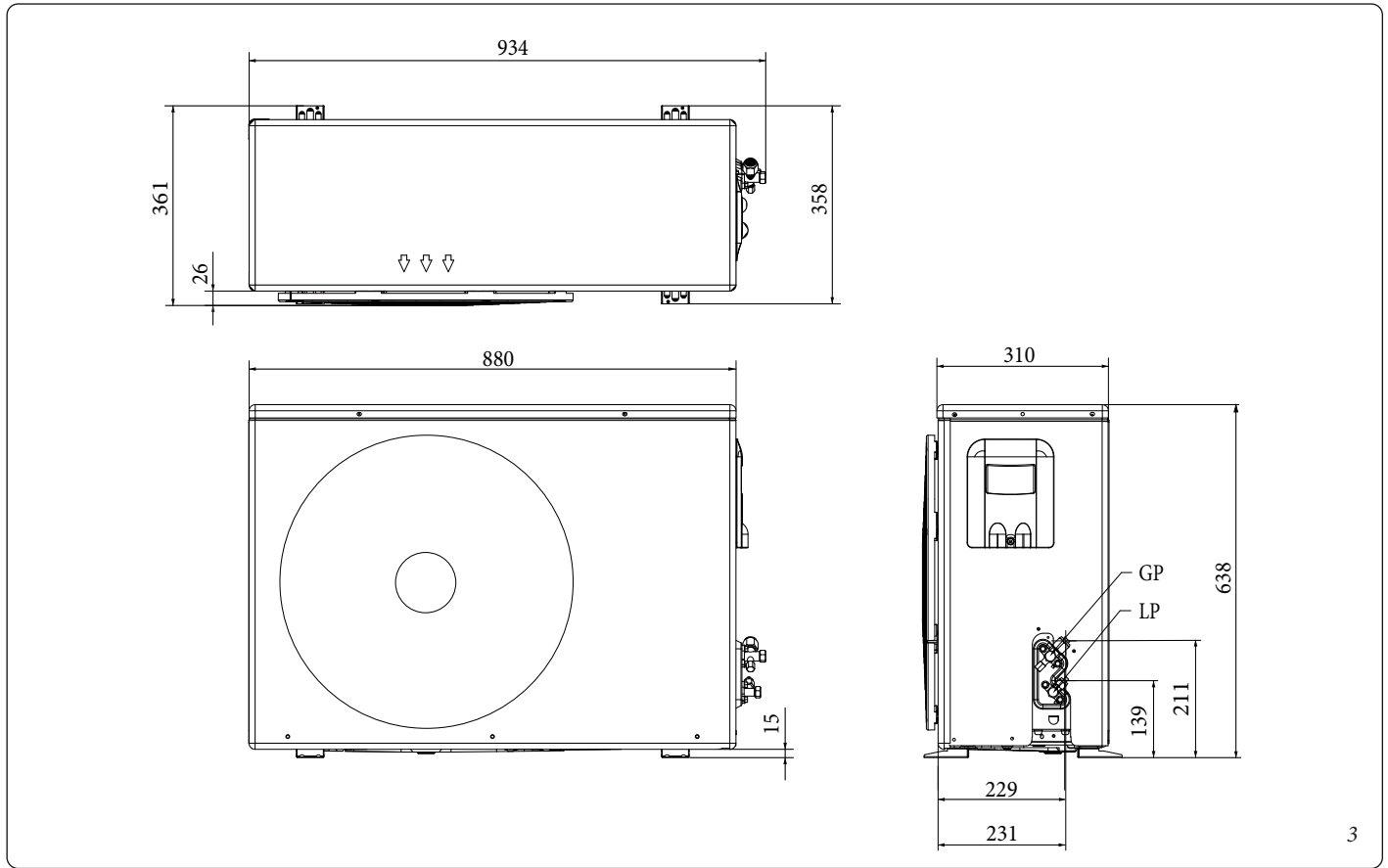

General dimensions in mm Audax Pro 9 V2

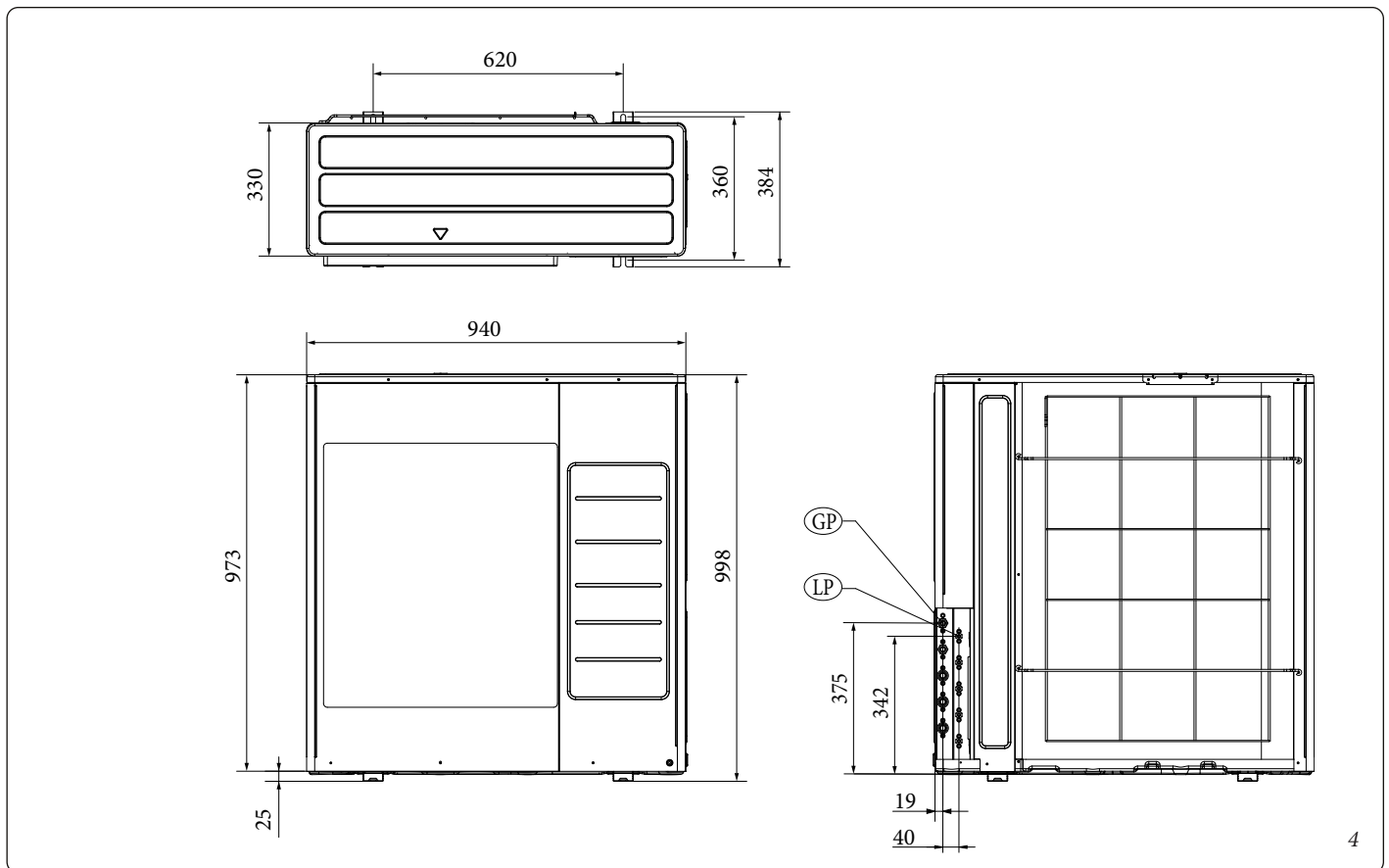

4 INSTALLATION OF THE UNIT.

4.1 OUTDOOR UNIT INSTALLATION POSITION.

Determine the installation site considering the following conditions and get the user's approval.

- The outdoor unit must not be positioned on its side or upside down, as the lubricating oil of the compressor could enter the cooling circuit and seriously damage the unit.
- Choose a dry and sunny position, though not exposed to direct sunlight or to strong wind.
- Do not block passages or exit routes.
- Choose a position where the noise of the condensing unit during operation or the discharge air do not disturb neighbours.
- Choose a position where the pipes and cables can be easily connected to another hydraulic system.
- Install the outdoor unit on a flat and stable surface capable of bearing its weight and which does not generate any useless noise and vibrations.
- Position the outdoor unit so that the air flow is directed outdoors.
- Position the outdoor unit where there are no trees or animals which could impair its operation.
- Leave sufficient space around the outdoor unit, especially for radios, computers, stereo systems, etc.

4.2 INSTALLATION GUIDE NEAR THE SEA.

Make sure to follow these guidelines for installation along the sea coast.

1. Do not install the appliance where it is directly exposed to sea water or breeze.
 - Install the product behind a structure (like a building) which can block the sea breeze.
 - Even when it is inevitable to install the appliance along the seacoast, make sure it is not exposed directly to the sea breeze by installing a protective wall.
2. Consider that the saline particles which adhere to the external panels must be sufficiently washed.
3. Since residual water at the bottom of the outdoor unit significantly promotes corrosion, make sure the slope does not affect drainage.
 - Keep the floor level so that rain does not make any puddles.
 - Be careful not to obstruct the drain hole with foreign substances
4. When the appliance is installed on the beach, clean it regularly with water to remove any attached salinity.
5. Make sure to install the appliance where water can be drained conveniently. In particular, make sure that the part of the base drains well.
6. If the appliance is drained during installation or maintenance, make sure to restore it.
7. Regularly check the condition of the product.
 - Check the installation site every 3 months and perform an anti-corrosion treatment with grease and water-repellent wax according to the conditions of the appliance.
 - Take appropriate measures to cover the product when it needs to be stopped for a long period of time, for example peak hours.
8. The product requires a special anti-corrosion treatment if installed within 500 m from the sea.

For further information, contact the Authorised Technical Assistance Centre.

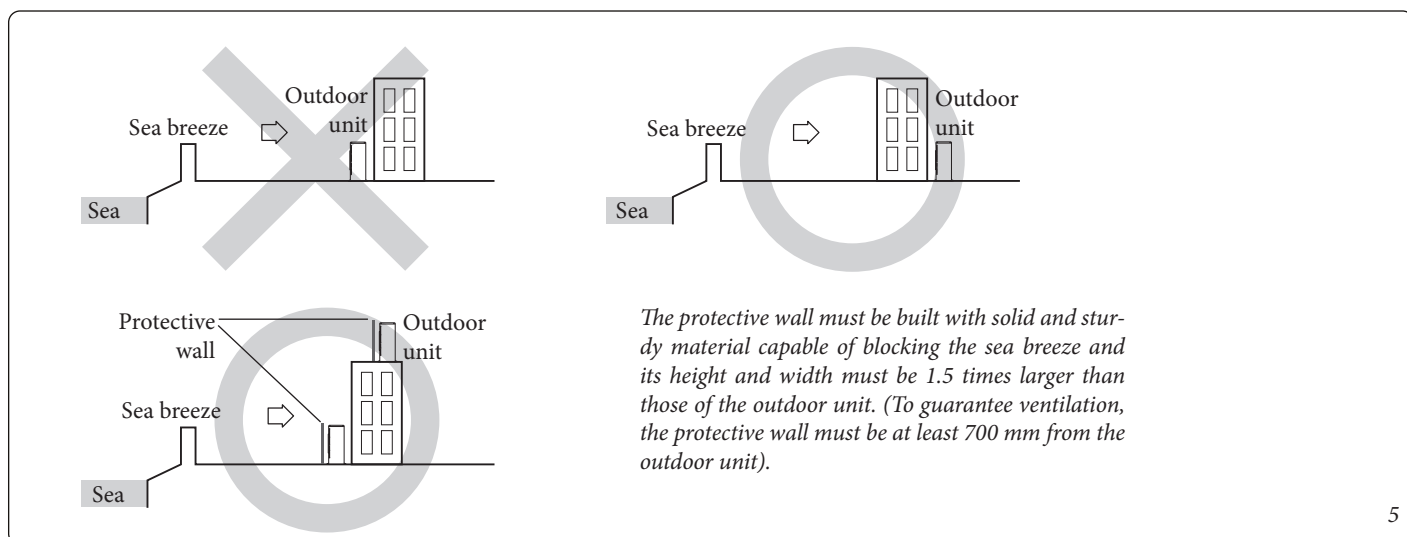

ATTENTION:

depending on the power supply conditions, power instability or voltage can cause malfunctioning of the parts or of the control system. (On ships or in places powered by an electric generator, etc.).



Do not install the condensing unit in the following places.

- Places where there is mineral oil or arsenic acid. Parts could be damaged by burnt resin. The capacity of the heat exchanger could be reduced or the condensing unit could fail.
- Places where exhaust fans eject corrosive gases such as sulphuric acid. Copper pipes or connection pipes would be corroded with subsequent refrigerant leaks.
- Places with the risk of leaks of combustible gases, carbon fibres or flammable dust. Places where thinners or petrol are handled.

ATTENTION:

this device must be installed according to current electrical standards. If the outdoor unit has a net weight over 60 kg, we suggest not to install it on the wall but on the floor.



- If the outdoor unit is installed at a certain height, make sure that its base is firmly fastened in place.
- Make sure that the condensate water collected by the drain hose is disposed of properly and safely.
- When the outdoor unit is installed on the road, it must be installed 2 m higher or in such a way that the heat emitted by the outdoor unit does not come into direct contact with passers-by. (Refer to standards in force relating to structures in the construction field).
- During installation or transfer of the product, do not mix the refrigerant with other gases, including air or unspecified refrigerant. Otherwise it could cause an increase in pressure, causing ruptures or injury.
- Do not cut or burn the container or the refrigerant pipes.
- Use clean parts, such as pressure gauge, vacuum pump and flexible hose to charge the refrigerant.
- Installation must be carried out by personnel qualified to handle the refrigerant. Also consult the regulations and laws.
- Do not allow foreign substances (lubricating oil, refrigerant other than R-32, water, etc.) to penetrate into the pipes.
- When mechanical ventilation is required, the vents must be kept clear of obstacles.
- Follow the local laws and standards to dispose of the product.
- Do not work in a closed area.
- The work area must be blocked.
- The refrigerant pipes must be installed in a position where there are no substances which can cause them to corrode.
- The following checks must be carried out for installation:

- The fan devices and the outlets work properly and are not obstructed.
- The signs and signals on the equipment must be visible and legible.
- Air out the room if any refrigerant leaks. Toxic gas could be generated if the refrigerant leak is exposed to fire.
- Make sure there are no flammable substances in the work area.
- Use a vacuum pump to bleed the air in the refrigerant.
- The refrigerant is odourless.
- The units are not explosion-proof. Therefore they must be installed in areas without risk of explosion.
- This product contains fluorinated gases which contribute to the global greenhouse effect. For this reason do not release the gases into the environment.
- To perform installation involving handling the refrigerant (R-32), use dedicated tools and materials of the pipes.
- Maintenance and installation must be carried out according to the manufacturer's instructions. If other qualified persons participate in maintenance, it must be carried out under the supervision of personnel competent in handling slightly flammable refrigerants.
- For maintenance of units containing slightly flammable refrigerants, safety checks must be performed to minimise the risk of fire.
- Maintenance must be carried out according to the control procedure to minimise the risk of refrigerant or flammable gas leakage.
- Do not install in places where there is the risk of combustible gas escaping.
- Do not install near sources of heat.
- Pay attention not to generate sparks as follows:
 - Do not remove the fuses while the unit is on.
 - Do not unplug the unit while it is on.
 - It is recommended to install the outlet high up. Lay the cables in such a way that they do not get tangled.
- After installation, check for leaks. Toxic gases could be generated in case of ignition with sources such as thermal fan, stove and cylinders. Use only specific refrigerant gas recovery cylinders.
- This could cause serious injury from freezing.
- Never touch any accidental refrigerant leak directly.

4.3 PREPARATION OF FIRE EXTINGUISHER.

- If hot work needs to be carried out, prepare adequate fire-fighting equipment.
- Set up a dry powder or CO₂ extinguisher in the vicinity of the charging area.

4.4 FREE IGNITION SOURCES.

- Make sure to store the units in a place without ignition sources in continuous operation (for example naked flames, gas-fired appliances or electric stoves).
- Maintenance technicians must not use ignition sources that generate the risk of fire or explosion.
- Potential ignition sources must be kept away from the work area where the flammable refrigerant could be released in the surrounding environment.
- The work area must be controlled to make sure that there are no flammable substance hazards or risks of ignition. A “No smoking” sign must be affixed.
- Under no circumstances must potential ignition sources be used during leak detection.
- Make sure that the gaskets and sealing materials are not worn.
- Safe parts are those with which personnel can work in a flammable environment. Other parts can cause ignition due to leaks.
- Only replace the components with the parts specified by the supplier. Other parts can cause ignition of refrigerant in the environment due to leaks.

4.5 VENTILATION OF THE AREA.

- Make sure that the work area is well ventilated before performing hot work.
- Ventilation must also be carried out during work.
- Ventilation must safely disperse all of the released gases and preferably expel them into the atmosphere.

4.6 LEAK DETECTION METHODS.

- The leak detector must be calibrated in an environment without refrigerant.
- Make sure that the detector is not a potential source of ignition.
- The leak detector must be set at LFL (lower flammability limit).
- Detergents containing chlorine must not be used for cleaning as the chlorine can react with the refrigerant and corrode the piping.
- Remove naked flames if you suspect any leaks.
- If the leak is detected during braze welding, all of the refrigerant must be recovered from the product or isolated (for example using shut-off valves). It must not be released directly into the environment. Oxygen-free nitrogen (OFN) must be used to purge the system before and during the braze welding process.
- The work area must be controlled with an appropriate refrigerant liquid detector before and during work.
- Make sure that the leak detector is suitable to be used with flammable refrigerants.

4.7 LABELLING.

- The parts must be labelled to guarantee that they have been dismantled and refrigerant emptied.
- The labels must bear the date.
- Make sure that specific labels are applied on the system to inform that it contains flammable refrigerant.

4.8 RECOVERY.

- When the refrigerant is removed from the system to perform maintenance or decommissioning, remove all of it (refer to legislation in force in the country of destination).
- When the refrigerant is transferred to cylinders, make sure that cylinders with refrigerant recovery are used, specific for slightly flammable gas.
- All of the cylinders used for the recovered refrigerant must be labelled.
- The cylinders must be equipped with pressure limiting valves and shut-off valves in the correct order.
- The recovery system must work normally according to the specified instructions and must be suitable for refrigerant recovery.
- Furthermore, the calibration scales must work normally.
- The couplings of the flexible hoses must not leak.
- The parts must be labelled to guarantee that they have been decommissioned and refrigerant emptied. Consult the manufacturer if you suspect any leaks.
- The recovered refrigerant must be sent back to the supplier in recovery cylinders with the Waste Transfer Note attached.
- Do not mix refrigerants in recovery units or cylinders.
- If compressors or compressor oils must be removed, make sure that they have been evacuated to an acceptable level to guarantee that no flammable refrigerant remains in the lubricant.
- The evacuation procedure must be performed before sending the compressor to the supplier.
- Only electrical heating of the compressor body is allowed to speed up the process.
- The oil must be safely drained from the system.
- Never install a motorised appliance to avoid ignition.
- Empty recovery cylinders must be vacuum and cooled before recovery.

4.9 INSTALLATION PLACE REQUIREMENTS.

- The outdoor unit must be installed in an open space always ventilated.
- Local regulations on gas must be complied with.
- For installation inside a building (whether the indoor unit or outdoor unit installed inside) a minimum surface of the conditioned area is mandatory according to IEC 60335-2-40: 2018 (see the reference table in the installation manuals of the indoor or outdoor unit).
- To handle, bleed or dispose of the refrigerant or to interrupt the refrigerant circuit, personnel must be in possession of a certificate supplied by an accredited authority in the sector.
- Do not install the indoor unit if there are drainage issues.

4.10 MOVING THE OUTDOOR UNIT WITH WIRE ROPES.

Fasten the outdoor unit with two wire ropes, 8 m or larger as shown in figures 6 and 7. Insert a piece of cloth between the outdoor unit and the cables to protect it from damage or scratches, then move the unit.

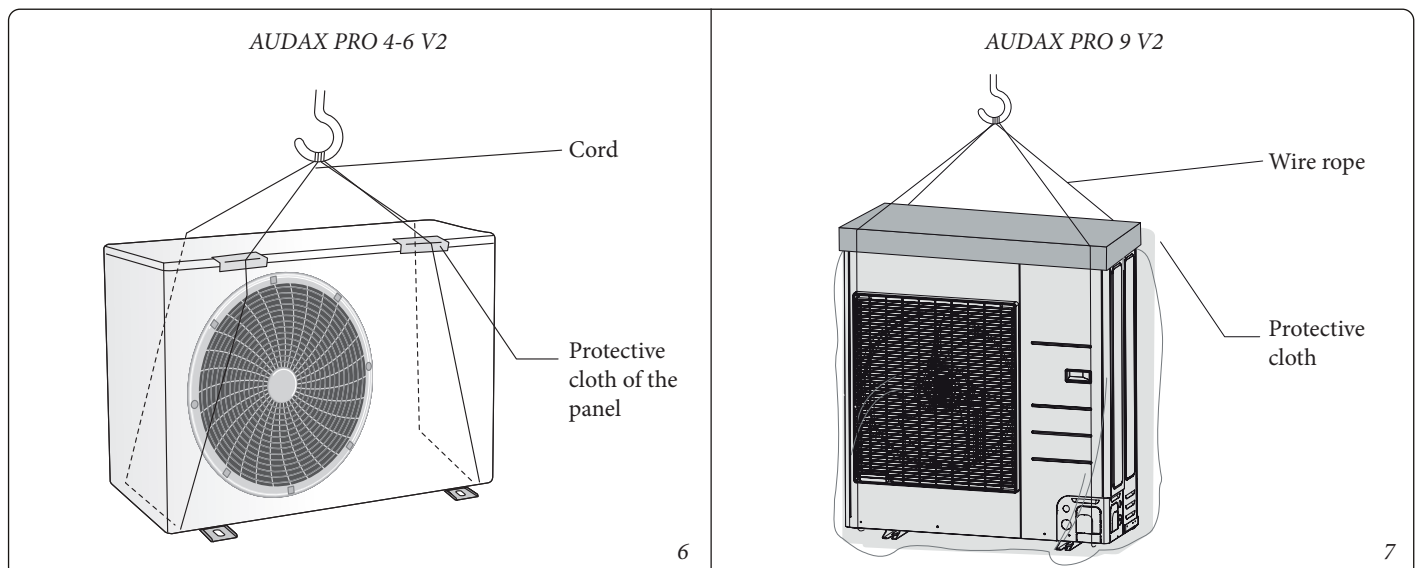

4.11 CLEARANCE REQUIREMENTS FOR THE OUTDOOR UNIT.

Installation of a single outdoor unit

(Unit: mm)

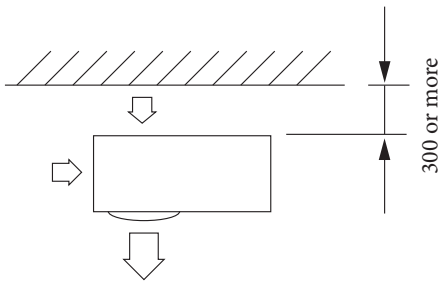

When the air outlet is opposite the wall

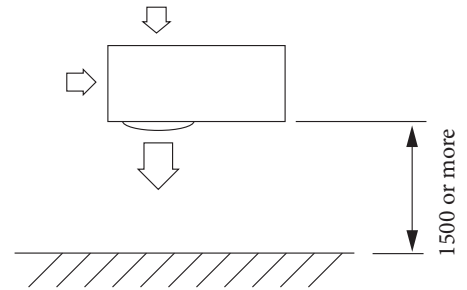

When the air outlet is towards the wall

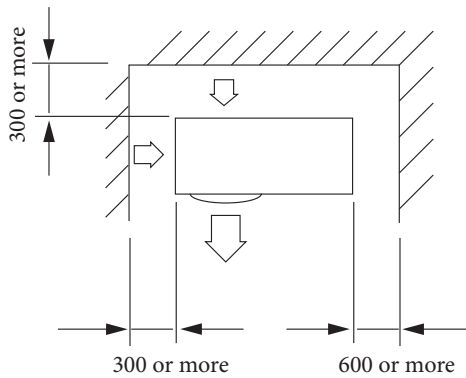

When 3 sides of the outdoor unit are blocked by the wall

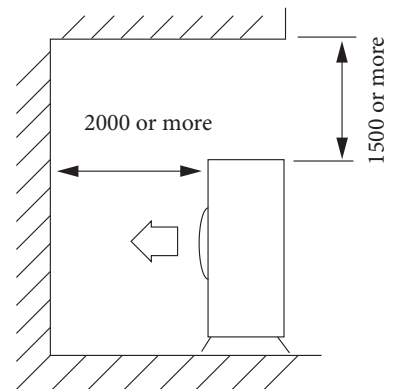

The top of the outdoor unit and the air outlet are towards the wall

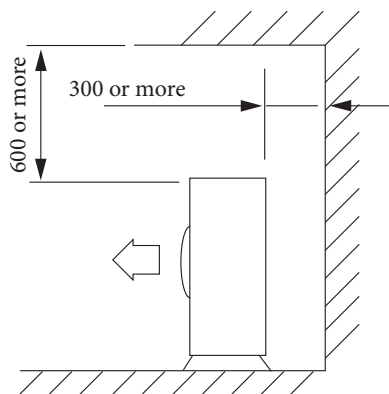

The top of the outdoor unit and the air outlet are opposite the wall

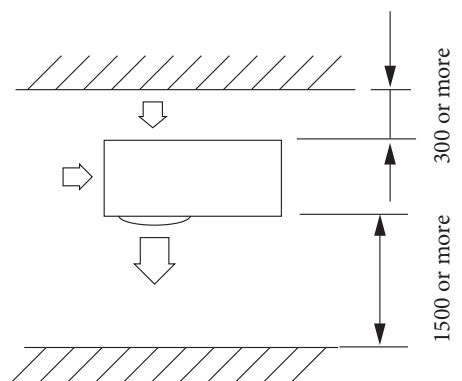

When the front and rear parts of the outdoor unit are towards the wall

Installation of several outdoor units

(Unit: mm)

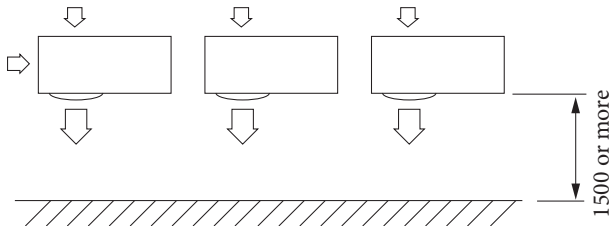

When the air outlet is towards the wall

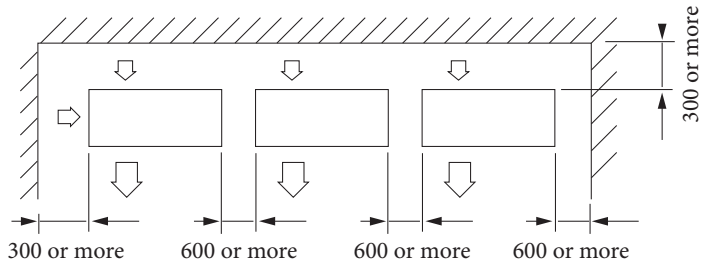

When 3 sides of the outdoor unit are blocked by the wall

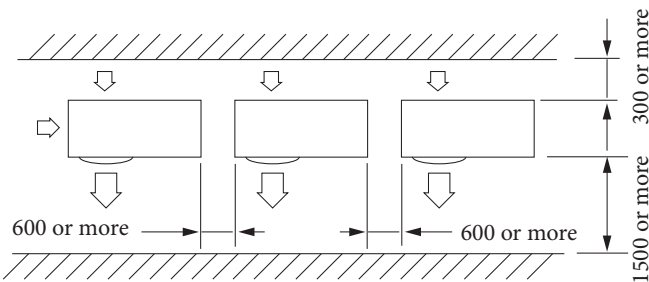

When the front and rear parts of the outdoor unit are towards the wall

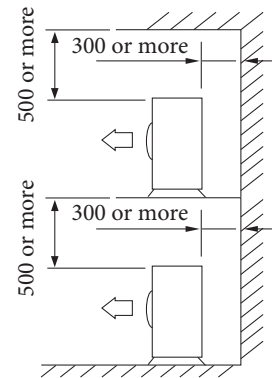

The top of the outdoor unit and the air outlet are opposite the wall

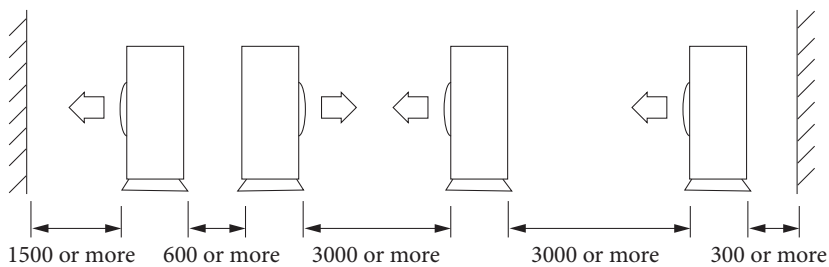

When the front and rear parts of the outdoor unit are towards the wall

9

ATTENTION:



the units must be installed complying with the specified distances so that it can be accessed from both sides and to guarantee the proper operation, maintenance and repair of the appliance. The parts of the unit must be able to be completely reached and removed in safe conditions (or persons or objects).

4.12 INSTALLING THE OUTDOOR UNIT.

The outdoor unit must be installed on a rigid and stable base to prevent any increase in noise or vibration. In particular if the outdoor unit needs to be installed in a position exposed to strong winds or at a certain height, it must be appropriately secured to the structure which supports it (floor or wall).

The anchor bolt must be at least 20 mm from the base surface.



ATTENTION:



- when tightening the anchor bolt, tighten the rubber washer so that the connection part of the bolt to the outdoor unit is not subject to corrosion.
- Make a discharge hole around the base for drainage of the outdoor unit.
- If the outdoor unit is installed on the roof, you must check the resistance of the ceiling and waterproof the unit.

4.13 MOUNT OF OUTDOOR UNIT.

Outdoor unit installed on the wall with mount.

- Make sure that the wall is capable of bearing the weight of the mount and of the outdoor unit.
- Install the mount as near as possible to the column.
- Install an adequate gasket to reduce noise and residual vibration transferred from the outdoor unit to the wall.

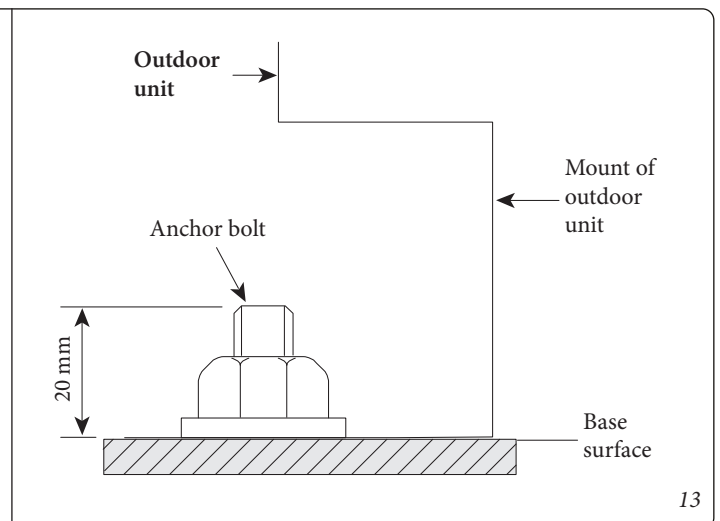
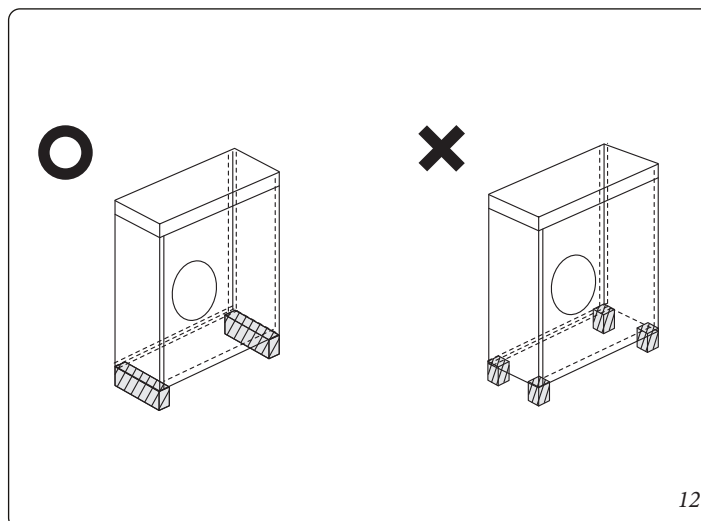
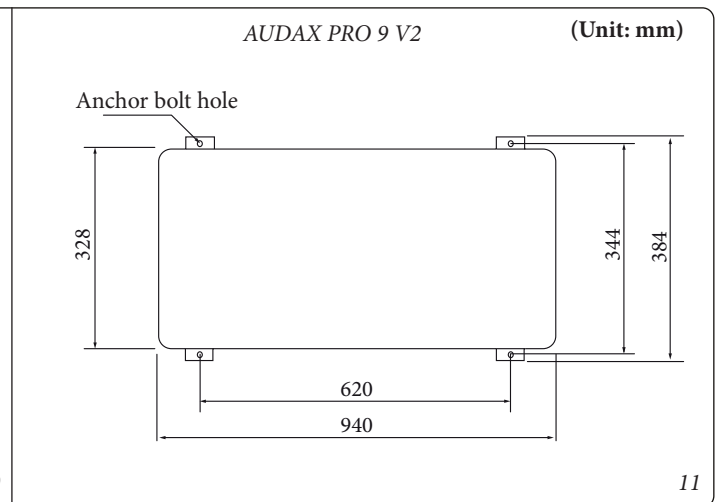
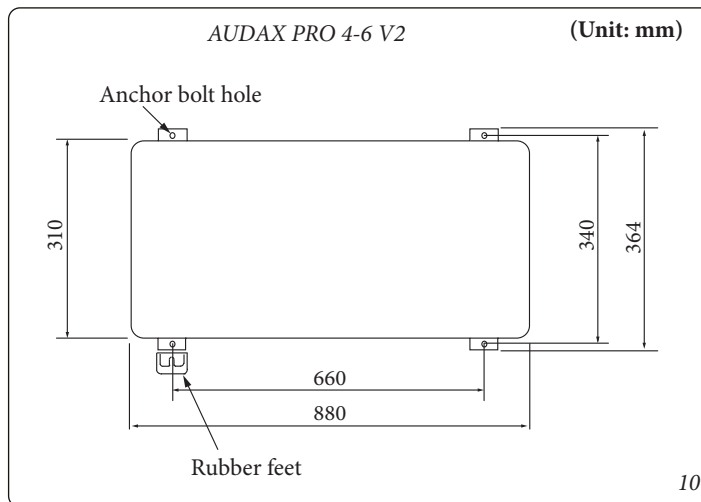

4.14 DRAIN.

General Area

When the condensing unit is running in central heating mode, ice could start to build up on the external finned coil. To prevent the ice from increasing, the system enters defrost mode, transforming the ice on the surface into water. The water dripping on the external finned coil is eliminated by making drainage holes to prevent the ice from growing at low temperatures.

Additional drainages are required if there is not sufficient space to drain the unit. Follow the instructions below.

- Leave more than 100 mm between the bottom of the outdoor unit and the ground to install the drain pipe.
- Insert the drain sleeve in the hole on the bottom side of the outdoor unit.
- Connect the drain pipe to the drain sleeve.
- Make sure that no dust or small branches clog the drain pipe.

ATTENTION:



insufficient drainage could downgrade performance and damage the system.

1. Prepare a water discharge channel around the base, to drain the water around the unit.
2. If the water does not drain easily, lift the unit onto a cement block base, etc. (the height of the foundation should be maximum 150 mm).
3. When installing the unit in a place subject to frequent snow-falls, pay special attention to elevate the base as high as possible.
4. If the unit is installed on a frame, assemble a waterproof plate (supplied on site) (within 150 mm from the lower side of the unit) to prevent the drain water from dripping. (See figure 15):

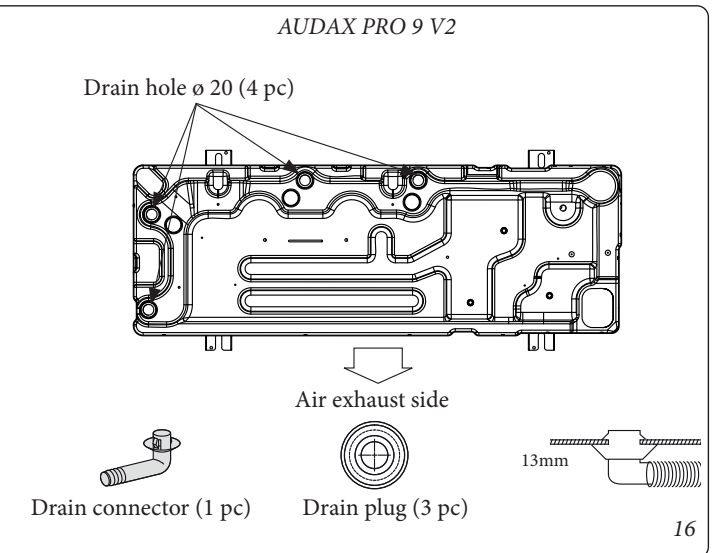
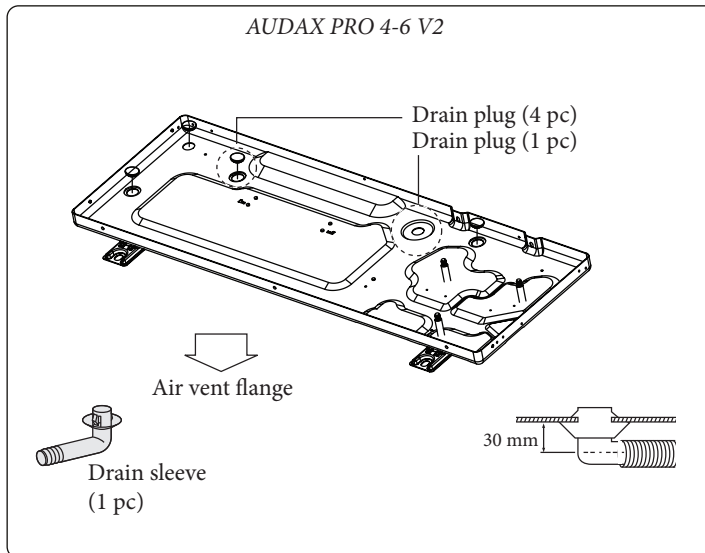
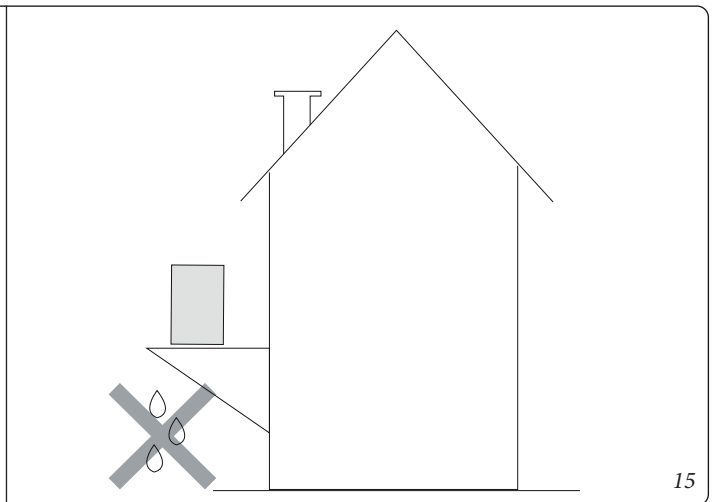
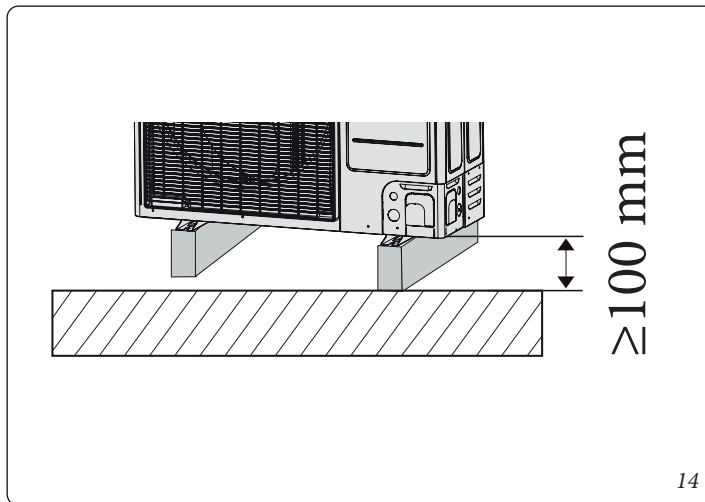

Area with intense snowfalls (natural drain)

Ice can build up when using the air conditioner in central heating mode. During de-icing, the condensate water must be drained safely. For the air conditioner to work properly, follow the instructions below.

- Leave more than 80 mm between the bottom of the outdoor unit and the ground for the installation (see figure 17).
- If the product is installed in a region with heavy snowfalls, leave sufficient space between the product and the ground (see figure 18).
- When you install the product, make sure that the mount is not positioned below the drain hole.
- Make sure that the drain water flows out correctly and safely.

ATTENTION:



- **in zones subject to heavy snowfalls, the snow buildup could block in the air vents. To avoid this occurrence, install a frame higher than the estimated level of the snow. Furthermore install a snow-proof roof to prevent the snow from piling up on the outdoor unit.**
- **In zones subject to snowfalls, do not install the discharge outlet and the drain plug in the outdoor unit. They could make the ground freeze. Therefore, take appropriate measures to prevent it.**

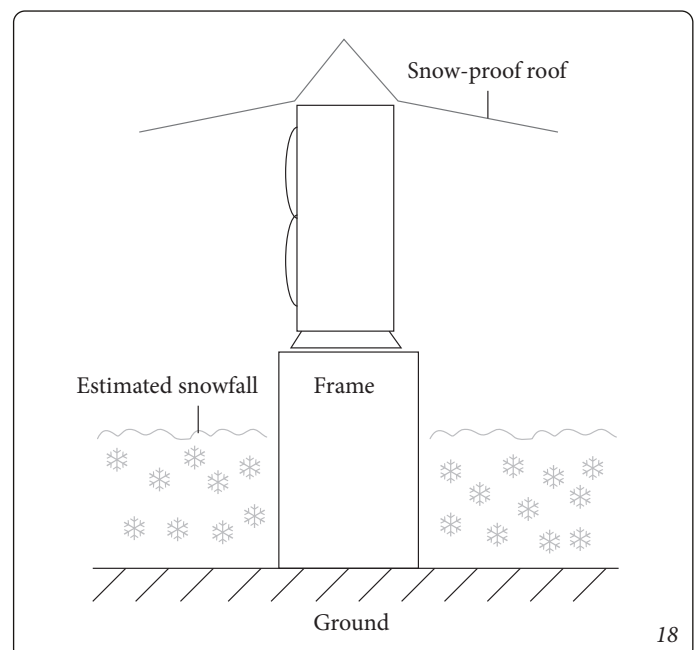
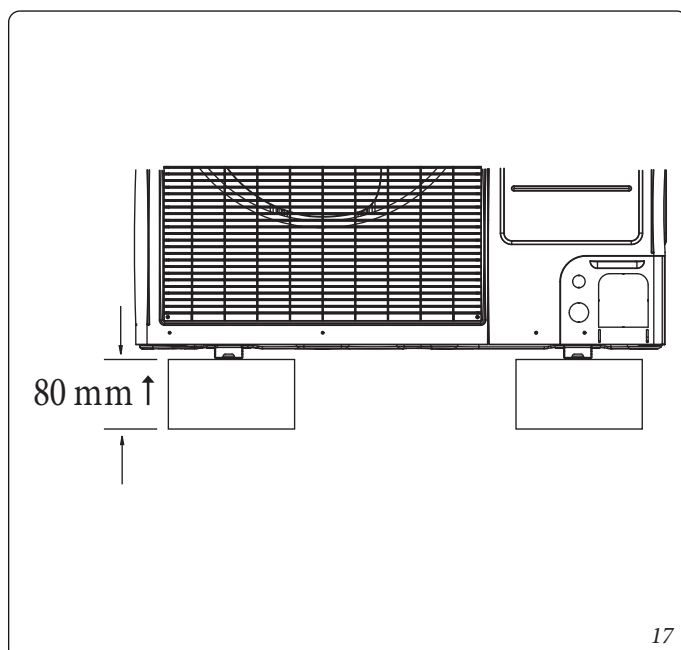

4.15 POSITIONING THE UNIT IN A RIGID CLIMATE.

To operate the appliance in low temperature outside environmental conditions, follow the instructions below.



- To avoid exposure to wind, install the unit with the intake side facing the wall.
- Do not install the unit in a place where the intake side can be directly exposed to the wind.
- To avoid exposure to the wind, install a deflector on the air exhaust side of the unit.
- In areas subject to heavy snowfalls, it is very important to choose an installation site where snow does not affect the unit. If blowing lateral snowfalls are possible, check that the coil of the heat exchanger is not affected by the snow (if necessary, build a side snow cover, see figure 19):

- Install the unit high enough above the ground so that it cannot be buried in the snow.
- The fan inside the outdoor unit runs regularly, as established, to prevent snow from building up inside the outdoor unit (see Snow accumulation prevention control page 46).
- The outdoor unit must be installed considering the direction of strong winds. These can turn the unit. Therefore the side of the unit, and not the front, should face the wind (see figures 20 and 21).

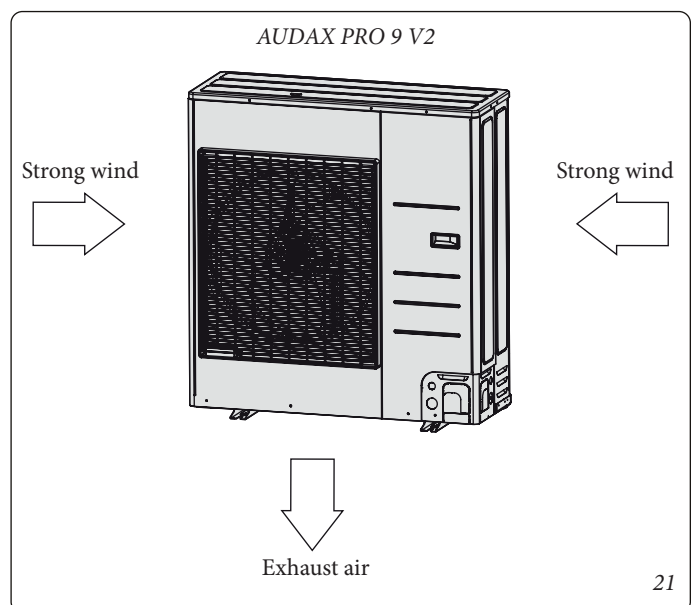
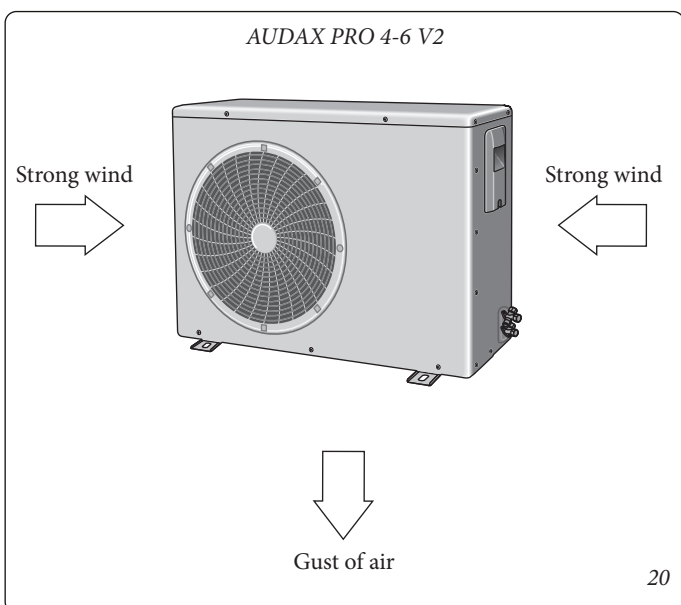
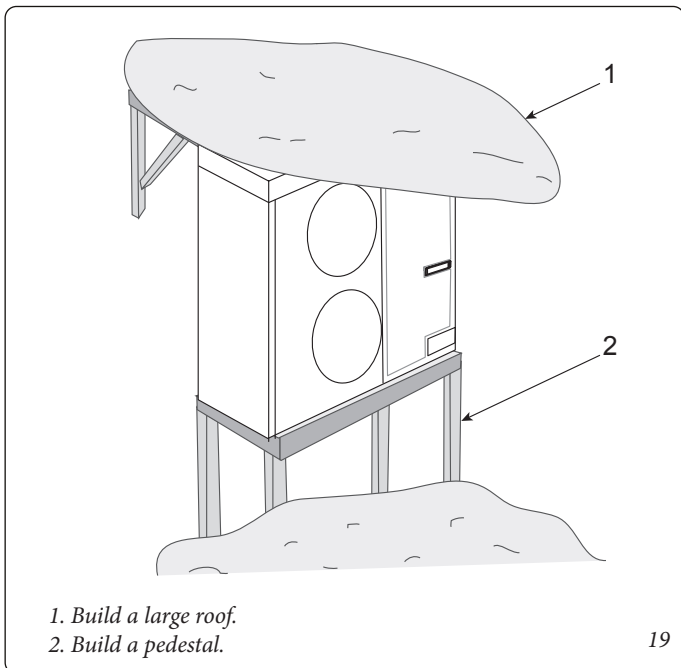

5 ELECTRICAL CONNECTIONS.

5.1 GENERAL CONFIGURATION OF THE SYSTEM.

Connection of power cable (single phase 2 wires)

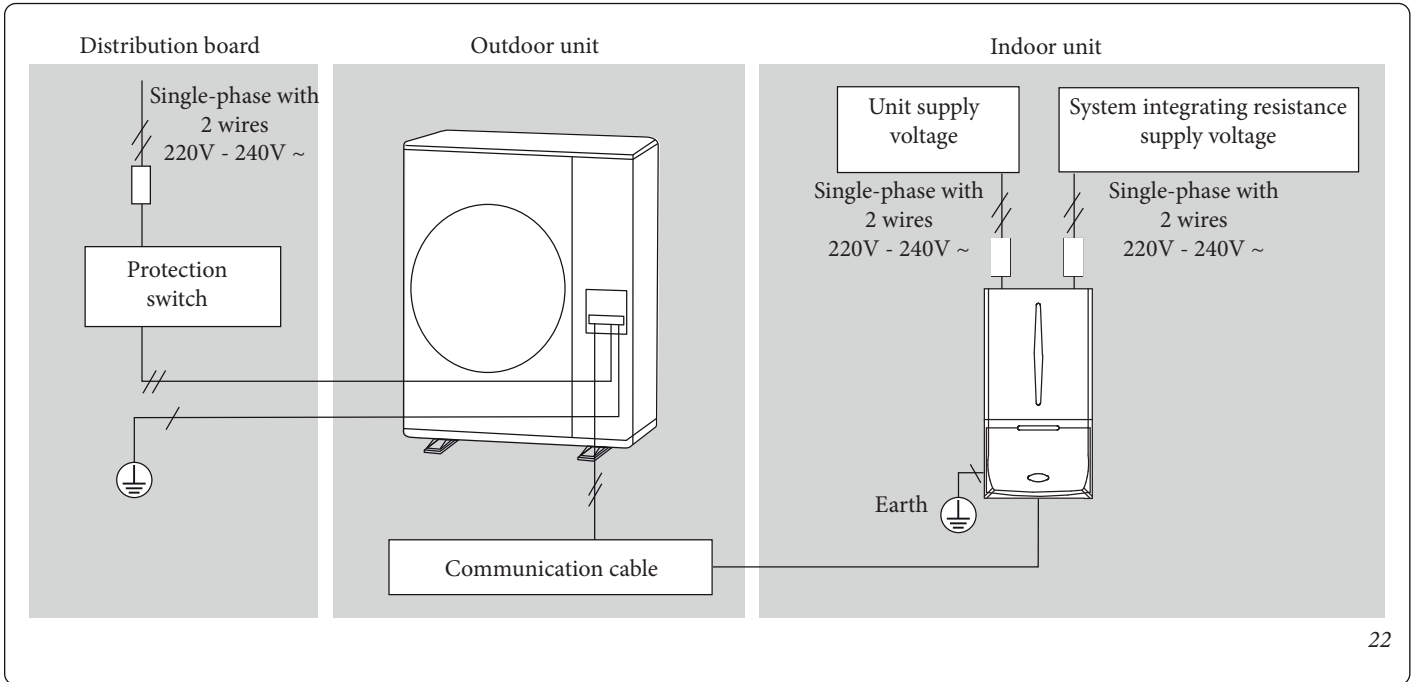

ATTENTION:

- install the electric panel close to the outdoor unit to make servicing and emergency operation convenient. ⚠
- Make sure to install the switch with protection against overcurrent and electric leakage. ⚡

6 CONNECTION OF THE CABLE.

6.1 POWER CABLE SPECIFICATIONS.

Outdoor unit	Rated		Voltage interval		MCA	MFA	Cable size
	Hz	Volt	Min	Max	Min. Circuit Amps	Max. Fuse Amps	
AUDAX PRO 4 V2	50	220-240	198	264	16.0 A	20.0 A	2.5 mm ²
AUDAX PRO 6 V2	50	220-240	198	264	16.0 A	20.0 A	
AUDAX PRO 9 V2	50	220-240	198	264	22 A	27.5 A	2.5- 4 mm ²

- The power cable is not supplied with the condensing unit.
- The power cables of parts of the outdoor appliances must be lighter than the flexible cables with polychloroprene sheath (designation code IEC:60245 IEC 57 / CENELEC:H05RN-F).
- This appliance complies with standard IEC 61000-3-12.

6.2 SPECIFICATIONS OF CONNECTING CABLES.

Power supply	Max/Min (V)	Communication cable
1Φ, 220-240 V ac, 50 Hz	±10%	from 0.75 to 1.5 mm ² , 2 wires

- Use H07RN-F or H05RN-F grade materials for the connection cable.

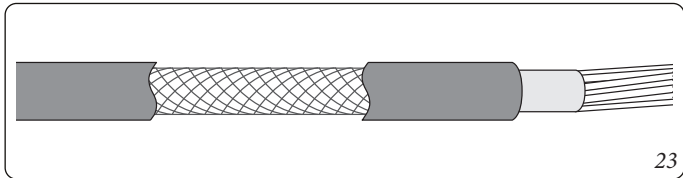

- If the outdoor unit is installed in a computer room, in a network room or in a server room, or where there is the risk of disturbance of the communication cable, use a double-shielded communication cable (aluminium tape/polyester + copper braid) type FROHH2R.

6.3 SPECIFICATIONS OF SINGLE PHASE TERMINAL BLOCK.

Audax Pro 4-6 V2		Audax Pro 9 V2	
AC power supply: M4 screw	AC communication: M4 screw	AC power supply: M5 screw	AC communication: M4 screw

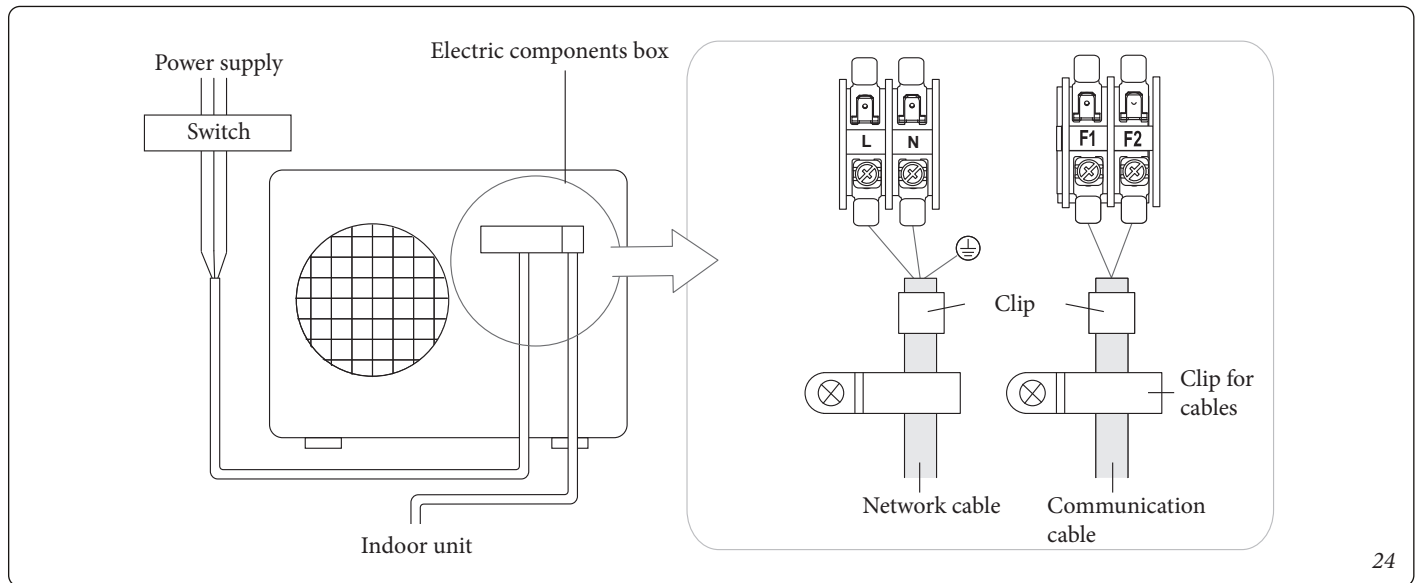

6.4 POWER CABLE CONNECTION DIAGRAM.

When using an earth leakage breaker (ELB) for a single phase system.



24

ATTENTION:

- the power cable must be connected to the relative terminal and secured with a clip. 
- Power imbalance must not exceed 2% of the rated voltage. 
 - If the imbalance is higher, the life of the capacitor could be shortened. If the power imbalance exceeds 4 % the supply power, the indoor unit protection trips, the unit stops and the error mode is indicated.
- To protect the product against water and blows, the power cable and the connection cable of the indoor and outdoor units must be laid in conduits. (With an adequate protection rating IP and choice of materials for the application made)
- Check that the main power connection is performed by means of a switch which disconnects all the poles, with a contact opening of at least 3 mm.
- The devices disconnected from the electric mains must be completely disconnected in the overvoltage category condition.
- Maintain a distance of 50 mm or more between the power cable and the communication cables.

Single-phase with 2 wires

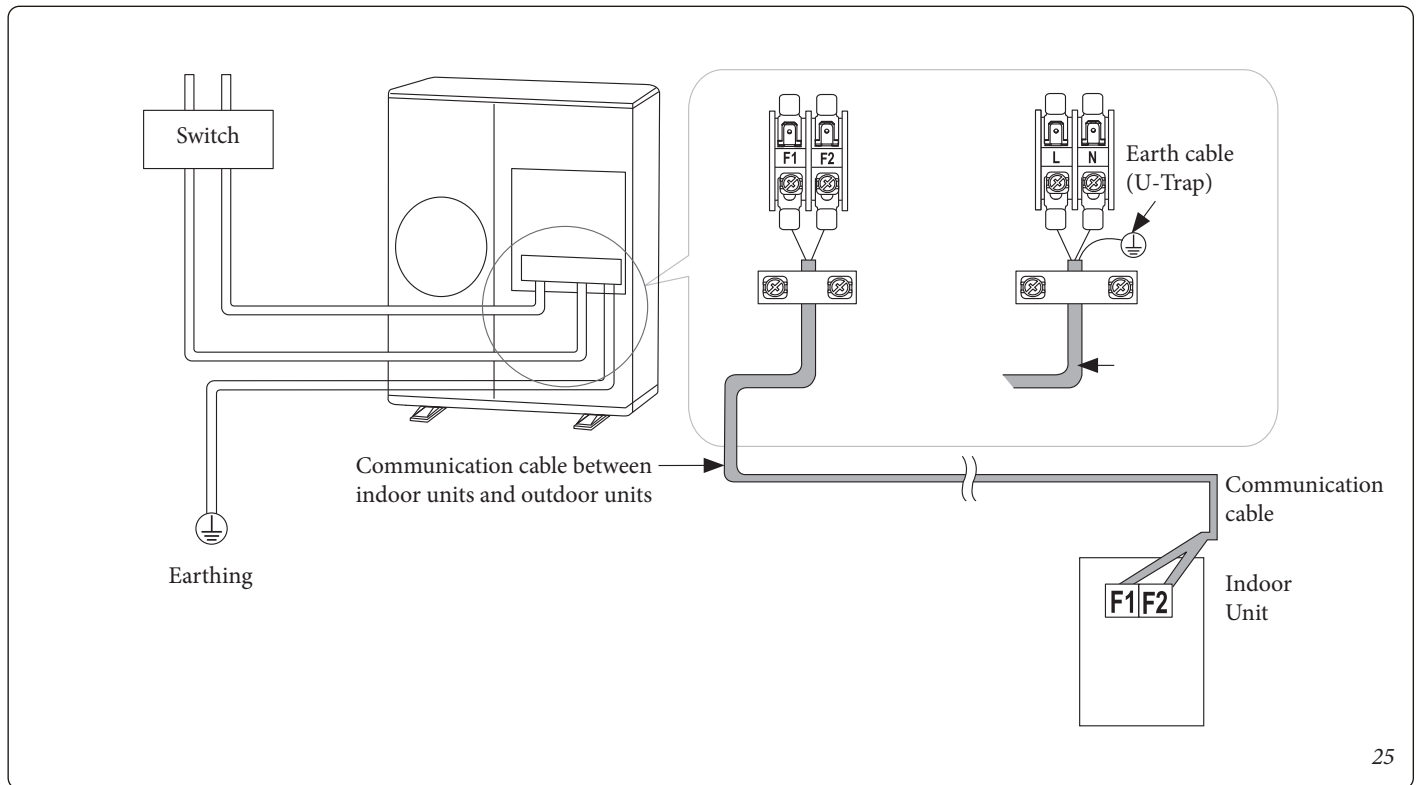

ATTENTION:

- when the outer cover of the power cable is removed, use appropriate instruments to avoid damaging the internal casing. ⚠️ ⚡
- Make sure to position the outer casing of the power cable and of the communication cable at least 20 mm in electric parts.
- The communication wiring should be made separately from the power cable and from other communication cables.

6.5 CONNECTION OF POWER TERMINAL.

- Connect the cables to the terminal block using the compressed ring terminal.
- Only connect regulation tables.
- Connection using a key capable of applying the nominal tightening torque to the screws.
- In the terminal is loose, a fire could occur due to an electric arc. Overtightening the terminal could damage it.

Tightening torque (kgf.cm)	
M4	12~18
M5	20~30

ATTENTION:

- **for products which use refrigerant R-32, avoid generating sparks by following the instructions below:**
- **Do not remove the fuses while the unit is on.**
- **Do not unplug the unit while it is on.**
- **It is recommended to install the outlet high up. Lay the cables in such a way that they do not get tangled.**



6.6 INSTALLATION OF EARTHING WIRE.

- Earthing must be carried out by technical personnel professionally qualified regarding safety.
- Use the earth wire referring to the specifications of the electric cable from the outdoor unit.

Power cable earthing

- Earthing standards may vary depending on the voltage and rated voltage of the place of installation of the condensing unit.
- Earth the power cable as follows.

Place of installation	High humidity	Average humidity	Low humidity
Power condition			
Electric potential lower than 150 V		Perform earthing in mode 3 (Note 1)	If possible, perform earthing in mode 3 for enhanced safety. (Note 1)
Electric potential higher than 150 V		Earthing must be carried out in mode 3 (Note 1) (In case of installation of a circuit breaker)	

- (Note 1) Earthing work 3.
- Earthing must be carried out by the installer technician

- Check whether the earth resistance is lower than 100Ω. When a circuit breaker is installed which can interrupt the electric circuit in case of a short circuit, the admissible earth resistance can be 30 ~ 500Ω.

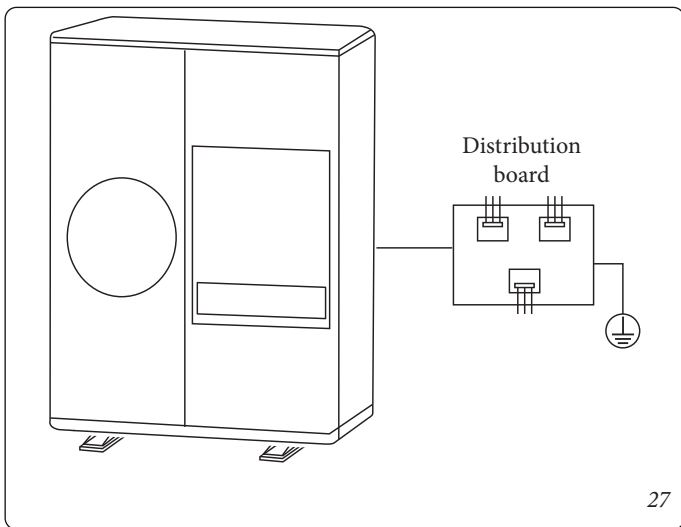
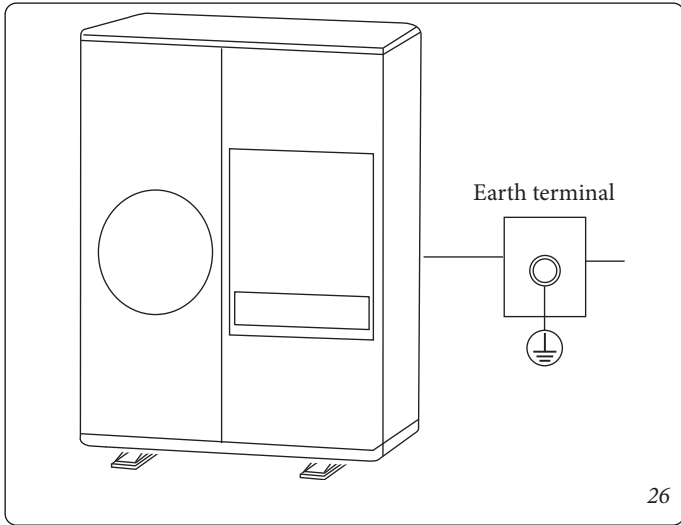
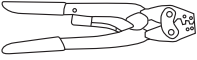
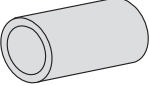

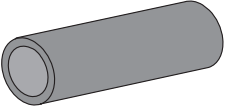

Figure 26: when using only the earth terminal.

Figure 27: when earthing the electric panel.

6.7 HOW TO CONNECT EXTENSION CABLES.

1. Prepare the following instruments:

Tools	Crimping pliers	Connection sheath (mm)	Electrical tape	Contraction sheath (mm)
Specifications	MH-14	20x ø 6.5 (HxOD)	Width 19 mm	70x ø 8.0 (LxOD)
Shape				

2. As shown in figure 28, strip the screen from the rubber and from the wire of the power cable.

- Strip 20 mm the cable screening from the preinstalled sheath.

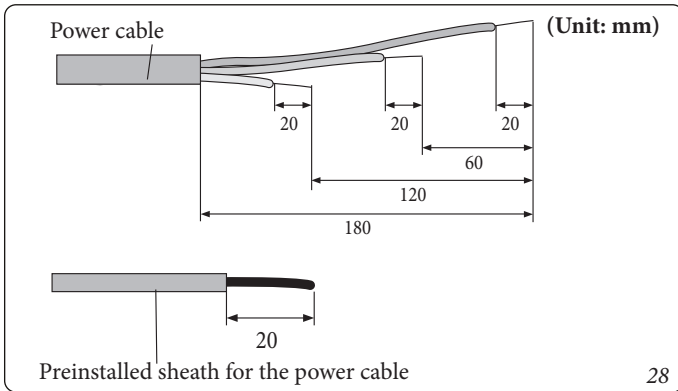

3. Insert both terminals of the copper wire of power cable into the connection sheath.

Method 1

- Push the copper wire into the sheath from both sides.

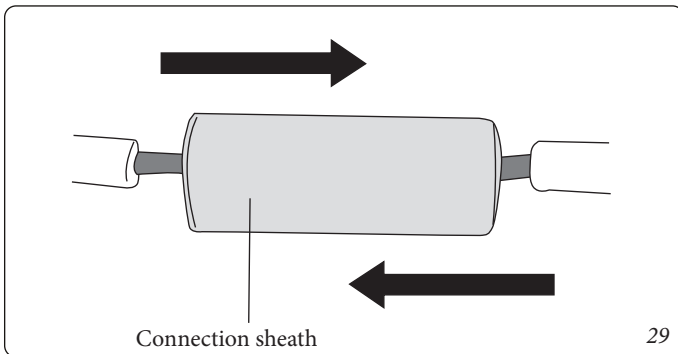

Method 2

- Twist the copper wires together and push them into the sheath.

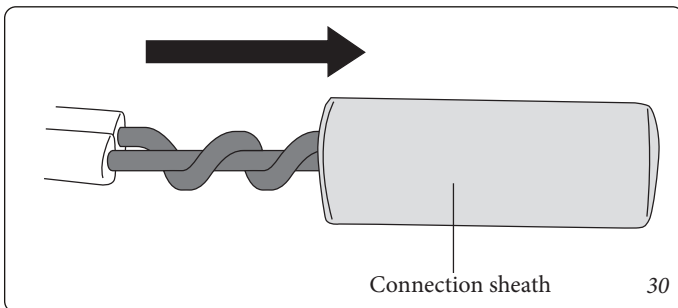

4. Compress the two points with the crimping pliers, turn them and repeat the operation on the other two points in the same position.

- The compressed dimension should be 8.0.

- After having squeezed it, pull both ends of the wire to make sure it is firmly compressed.

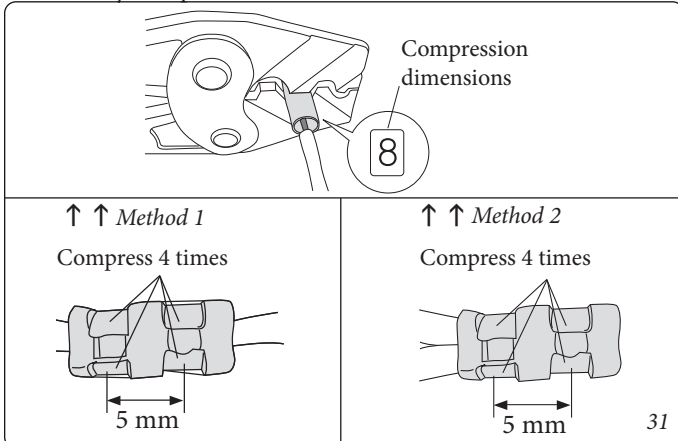

5. Wrap it in at least two turns of electrical tape and position the contraction sheath in the middle of the tape.

Three or more layers of tape are required.

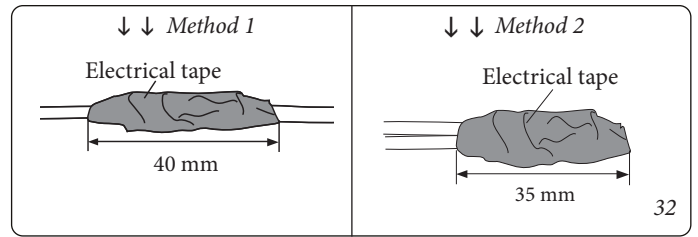

6. Heat the contraction sheath to contract it.

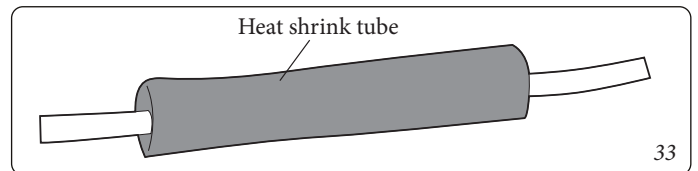

7. After having completed the contraction stage, finish the operation by wrapping it with electrical tape.

ATTENTION:

- make sure that the parts to be connected are not exposed to the outside. ⚠
- Make sure that the electrical tape and the contraction sheath are made with approved reinforced insulating materials with the same voltage and current values as the power cable. (Comply with local standards for the extensions). ⚡

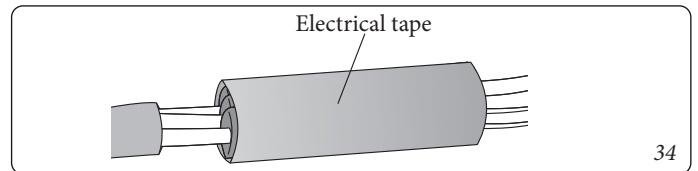

ATTENTION:

- in case of extension of the electric wire, do NOT use a round press-fit bushing. ⚠
- Incomplete electrical connections can cause electrocutions or fire. ⚡

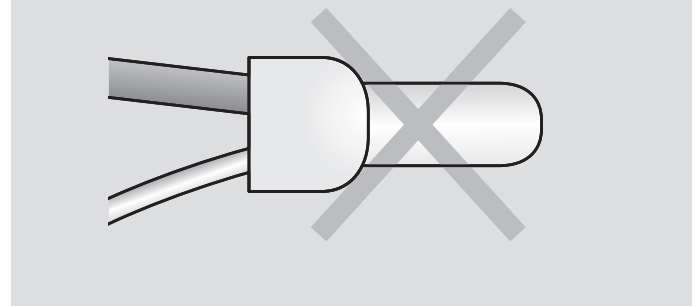

7 CHECKING CORRECT EARTHING.

If the electric distribution circuit is not earthed or earthing does not comply with the specifications, an earthing system must be installed. The corresponding accessories are not supplied with the condensing unit.

1. Select an earth electrode compliant with the specifications indicated in figure 35.

2. Connect the flexible hose to the coupling.

- Preferably on a hard or moist ground rather than sandy or gravelly due to the greater earth resistance.

- Away from structures or underground structures, such as gas pipes, water pipes, telephone lines or buried cables.

- At least 2 m from a lightning conductor and from its cable.

- The earth wire for the telephone line cannot be used to earth the condensing unit.



3. Finish by wrapping electrical tape around the pipes in the direction of the outdoor unit.

4. Install a green/yellow earth wire:

- If the earth wire is too short, mechanically connect an extension cable and wrap it with electrical tape (do not bury the connection).

- Secure the earthing cable in position with appropriate anchors.

- If the earth electrode is installed in an area with heavy traffic, its wire must be connected securely.



5. Carefully check the installation by measuring the earth resistance with an ohmmeter. If the resistance is higher than the required level, plant the electrode deeper into the ground or increase the number of earth electrodes.

6. Connect the earthing cable to the electric components box inside the outdoor unit

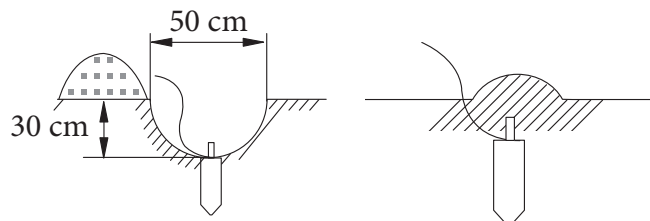
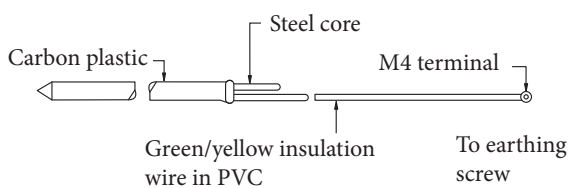

8 INSTALLATION OF CHILLER LINES.

- Install the refrigerant pipe within the maximum allowed length, difference in height and width after the first branching pipe.
- The R-32 pressure is high. Use only a regulation refrigerant pipe and follow the installation instructions.
- Use a free refrigerant pipe in an environment without dangerous ions, oxide, dust, iron content or humidity.
- Use instruments and accessories suitable for R-32.

Manifold pressure gauge	- Use the manifold pressure gauge only for R-32 to prevent the inflow of foreign substances
Intake pump	- Use an intake pump with non return valve to prevent the pumped oil from flowing back when the intake pump is stopped. - Use a vacuum pump suitable to reach the necessary degree of vacuum
Countersunk nut	- Use only the countersunk nut supplied with the product

8.1 ALLOWED LENGTH OF THE REFRIGERANT PIPE AND INSTALLATION EXAMPLES.

The maximum lengths of the chiller lines are listed below, based on the condensing unit model and the type of installation.

Dimensions	Audax Pro 4-6 V2 (Outdoor unit)	Audax Pro 9 V2 (Outdoor unit)	Notes
A	less than or equal to 30 m	less than or equal to 35 m	
H1	less than 20 m	less than 20 m	*If the outdoor unit is in a position equal to or less than 15 m
H2	less than 20 m	less than 20 m	*If the outdoor unit is in a position equal to or less than 15 m

* Contact the manufacturer if longer.

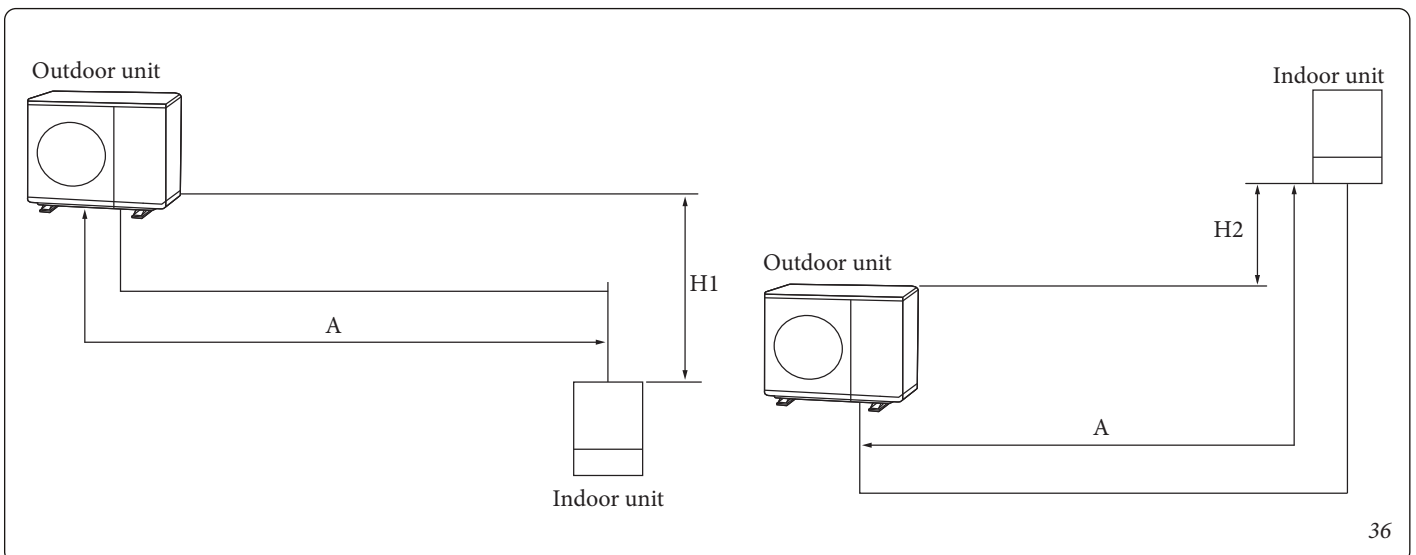

- Since the condensing unit contains refrigerant R-32, make sure that it is installed, used and preserved in a room with a surface larger than the minimum specified in the following table:

Minimum area required for the room (A, m ²)			
m (kg)	Ceiling-mounted	Wall-mounted	On the ground
≤ 1.842	No requirement		
1.843	3.64	4.45	28.9
1.9	3.75	4.58	30.7
2.0	3.95	4.83	34.0
2.2	4.34	5.31	41.2
2.4	4.74	5.79	49.0
2.6	5.13	6.39	57.5
2.8	5.53	7.41	66.7
3.0	5.92	8.51	76.6
3.2	6.48	9.68	87.2
3.4	7.32	10.9	98.4
3.6	8.20	12.3	110
3.8	9.14	13.7	123
4.0	10.1	15.1	136
4.2	11.2	16.7	150
4.4	12.3	18.3	165
4.6	13.4	20.0	180
4.8	14.6	21.8	196
5.0	15.8	23.6	213

- m: Total refrigerant load in system

- A: Minimum required surface of the floor

- **IMPORTANT: it is mandatory to take the above table into consideration or the requirements of local laws regarding the minimum installation surface of the rooms.**

- The minimum installation height of the indoor unit is 0.6 m when installed on the ground, 1,8 m when wall-mounted and 2.2 m when ceiling-mounted.

8.2 SELECTION OF REFRIGERANT PIPE.

Capacity of outdoor unit (kW)	Liquid side (mm)	Gas side (mm)
AUDAX PRO 4 V2	ø 6.35	ø 15.88
AUDAX PRO 6 V2		
AUDAX PRO 9 V2		

- Install the refrigerant pipe depending on the capacity of the outdoor unit.

- Make sure to use C1220T-1/2H (semirigid) pipes when over Ø19.05 mm. If you use C1220T-O (soft) pipes for Ø19.05, it could rupture and cause injury.

Degree of hardening and minimum thickness of refrigerant pipe

Outside diameter (mm)	Minimum thickness (mm)	Degree of hardening
ø 6.35	0.7	C1220T-0
ø 15.88	1.0	
ø 15.88	0.8	C1220T-1/2H O C1220T-H

8.3 KEEP THE REFRIGERANT PIPE CLEAN AND DRY.

- To prevent foreign bodies or water from entering the pipe, they must be sealed with plugs.

8.4 CUTTING AND FLANGING OF PIPES.

1. Make sure to have prepared the required tools.
- pipe cutter, deburring tool, flaring tool, clamp, etc.
2. If the pipes need to be shortened, cut them with a pipe cutter, making sure that the cutting-edge is perpendicular to the length of the pipe.
- Figure 37 shows some examples of correct and incorrect cutting edges.
3. To avoid gas leaks, remove all of the burrs on the pipe cutting edge using a reamer.

ATTENTION:

- while removing the burrs, keep the pipe turned downwards so that they do not drop inside.



4. Insert a countersunk nut into the pipe and modify flaring.
5. Check that the pipe is correctly countersunk.
- Figure 40 shows some examples of incorrectly countersunk pipes.
6. Align the pipes connect them easily. First tighten the countersunk nuts with your hands and then with a torque wrench, at the tightening torque values indicated in the table in figure 41.

Overtightening can cause gas leaks.

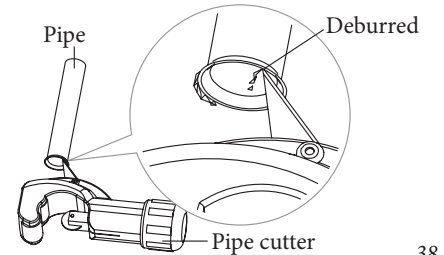
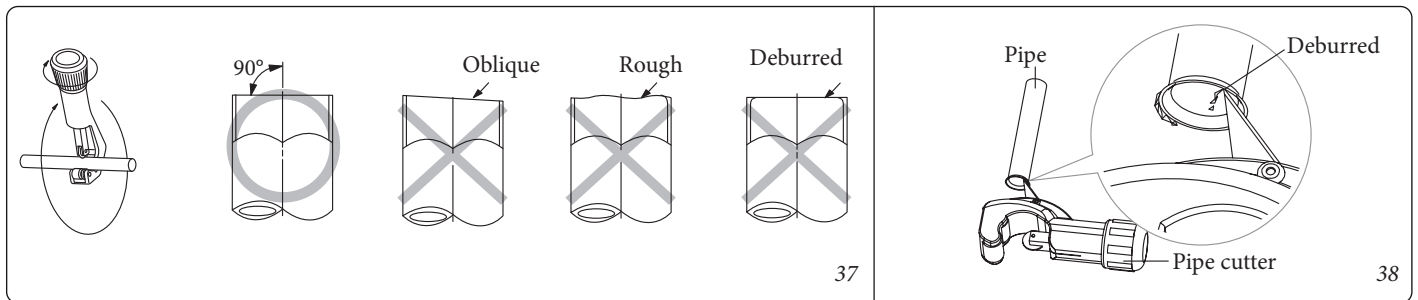

Outside diameter [D (mm)]	Depth [A (mm)]	Flaring dimensions [B (mm)]
ø 6.35	1.3	8.7 ~ 9.1
ø 15.88	2.2	19.3 ~ 19.7

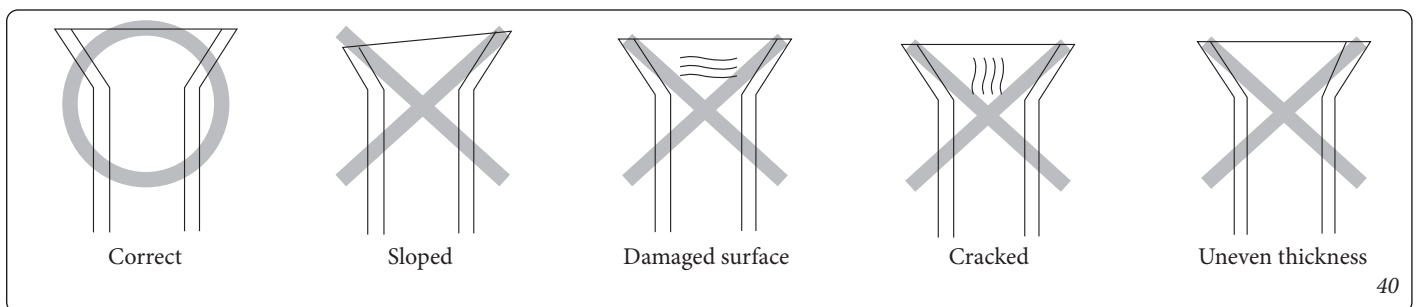

Outside diameter [mm (inches)]	Torque (N·m)
ø 6.35 (1/4")	14 ~ 18
ø 15.88 (5/8")	68 ~ 82

ATTENTION:

- it is necessary to purge with oxygen-free nitrogen during braze welding.
- Tighten the nuts at the specified torques. In case of overtightening, the nuts could break resulting in refrigerant leakage
- Protect or enclose the refrigerant pipes to avoid mechanical damage.
- Keep the length of the pipes at a minimum, to minimise the maximum refrigerant load owing to extension of the pipes.
- During the connection of the pipes, make sure that they do not interfere or come into contact with surrounding objects, to avoid refrigerant leaks caused by physical damage.
- Make sure that the areas where the pipes are installed comply with national regulations on gas.
- Always charge the refrigerant and weld the pipes in good ventilation conditions.

ATTENTION:

- weld the pipes for the mechanical connections only when the refrigerant is not in circulation.
- When reconnecting the piping, make sure that the flares are retightened to avoid refrigerant leaks.
- When working on the pipes and on the flexible connections of the refrigerant, make sure that they are not damaged by surrounding objects.
- For installation while handling the refrigerant R-32, use special instruments for refrigerant R-32 (pressure gauge, vacuum pump, flexible load hose, etc.).
- During tests, do not pressurise the appliances with a pressure higher than the maximum admissible pressure (indicated on the rating data of the unit).
- Never touch any accidental refrigerant leak directly. This could cause serious injury from freezing.
- Never install a dryer on this unit to guarantee its duration.
- If pipes longer than those specified in the codes and standards relative to piping are required, refrigerant must be added in the pipes. Otherwise the indoor unit could freeze.
- While removing the burrs, keep the pipe turned downwards so that they do not drop inside.

8.5 CHOOSE THE INSULATION OF THE REFRIGERANT PIPE.

- Select the appropriate insulations according to the size of the gas and liquid pipes.
- The standard conditions are with a temperature of 30° C and a humidity of 85%. If the units are installed in extreme climatic conditions, select the insulation from the table in figure 42.

ATTENTION:



- apply the insulation in such a way that it does not expand and use the adhesives on the relative connection part to keep out moisture.
- Wrap the refrigerant pipe in insulating tape if it is exposed to external sunlight.
- Install the refrigerant pipe making sure that the insulation is not thinner on bends or in the fairlead.

8.6 INSULATING THE REFRIGERANT PIPE.

- You must check that there are no gas leaks before completing the entire installation process.
- Use EPDM insulation which meets the conditions described in the table in figure 43.
- Make sure to insulate the refrigerant pipes, the joints and the connections with class 'o' material.
- By insulating the piping, condensate water does not drip from the pipes, improving the condensing unit's capacity.
- Check that there are no cracks in the insulation where the pipe bends.

8.7 BRAZE WELDING THE PIPE.

- Make sure there is no moisture inside the pipe.
- Make sure there are no foreign bodies or impurities in the pipe.

Replacing nitrogen gas.

1. Use oxygen-free nitrogen during braze welding of the pipes, as shown in figure 44.
2. Oxidation can form in the pipe if nitrogen gas is not used during braze welding. This can damage the compressor and valves.
3. Adjust the flow of the replacement gas with a pressure regulator to maintain the flow rate no lower than 0.05 m³/hour.
4. Execute braze welding of the service valve after having protected the valve.

Type of pipe	Pipe diameter (mm)	Insulation thickness		Notes
		Normal (Below 30°C, 85 %)	High humidity (Over 30°C, 85 %)	
		EPDM, NBR		
Liquid	ø 6.35 ~ ø19.05	9	9	The material must be able to withstand heat beyond 120°C
Gas	ø15.88	19	25	

42

Item	Unit	Standard	Notes
Density	g/cm ²	0.048 ~ 0.096	KSM 3014-01
Path dimensions changed by heat	%	-5 or less	
Water absorption rate	g/cm ²	0.005 or less	
Thermal conductivity	kcal/m·h·°C	0.032 or less	KSL 9016-95
Moisture transpiration factor	ng/(m ² ·s·Pa)	15 or less	KSM 3808-03
Moisture transpiration degree	{g/(m ² ·24h)}	15 or less	KSA 1013-01
Dispersion of formaldehyde	mg/l	-	KSF 3200-02
Oxygen rate	%	25 or less	ISO 4589-2-96

43

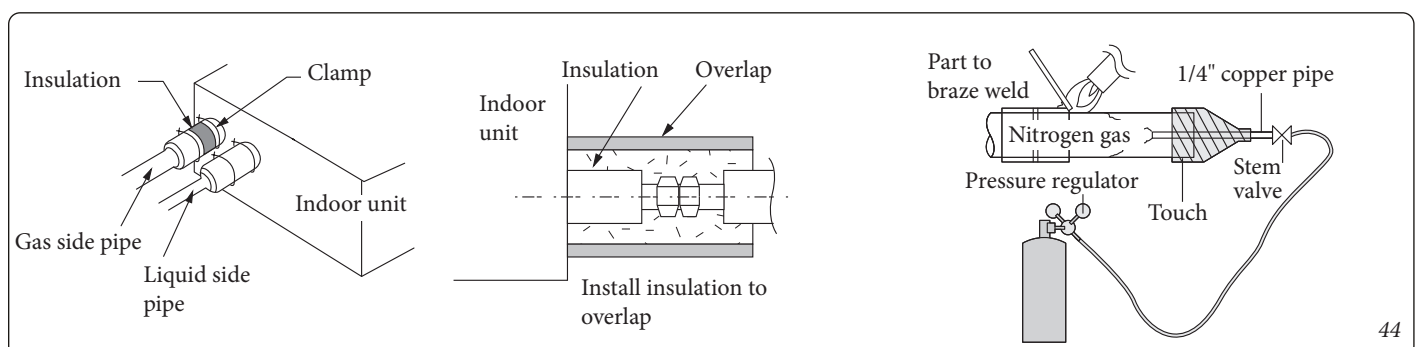

44

8.8 TESTING FOR REFRIGERANT GAS LEAKS.

- Use the manifold pressure gauge for R-32 to prevent the inflow of foreign substances and to withstand the internal pressure.
- Pressure test with dry oxygen-free nitrogen.

Apply pressure on the liquid side and gas side of the pipe with nitrogen gas at 4.6 MPa (46.9 kgf/cm²).

Applying a pressure higher than 4.6MPa could damage the pipes. Apply pressure using the pressure regulator.

Keep it for at least 24 hours to see whether the pressure drops

After applying the nitrogen gas, check the pressure variation with the pressure regulator.

If the pressure drops, check whether there are gas leaks

If the pressure has changed, use soapy water to find out where the leak is. **Recheck the pressure of the nitrogen gas.**

Maintain a pressure of 1.0 MPa before **putting under vacuum and again check** for any gas leaks

After having checked the first gas leak, keep pressure at **1.0 MPa to check for further gas leaks.**

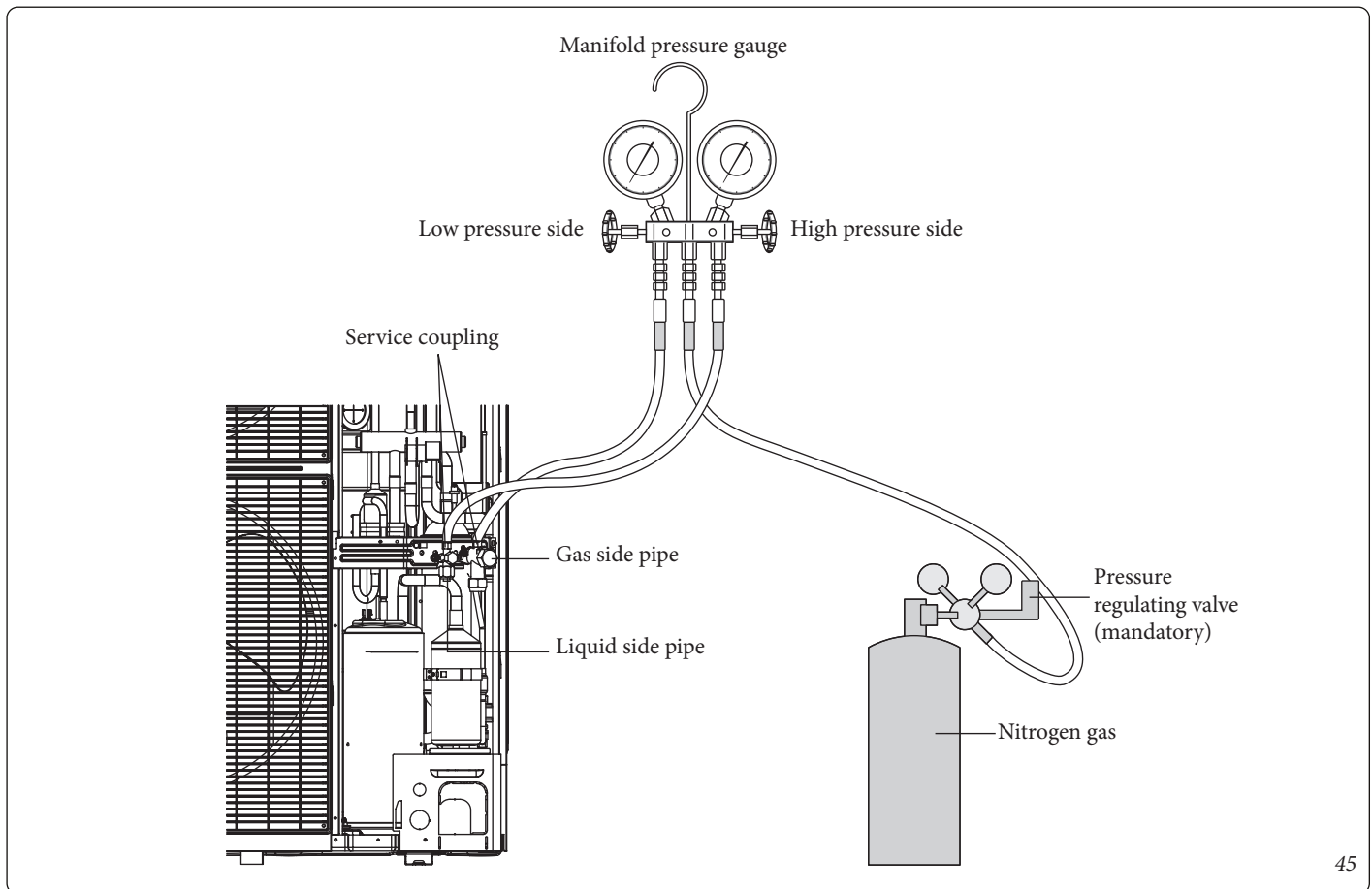

- Make sure to use a solution for the recommended bubble test to look for gas leaks. Soapy water could cause cracks in the countersunk nuts or corrode the countersunk joints.

ATTENTION:

- **injuries could occur when the joint detaches on a high pressure side and the gas comes into contact with your body. Make sure to tighten the joint to prevent these accidents.**



8.9 CREATING VACUUM.

The following procedure refers to Audax Pro 9 V2.

In the other cases, the procedure is the same except for the fact that there is only one service connection, instead of two.

- Use only the instruments for R-32 to prevent the inflow of foreign substances and to withstand the internal pressure.
- Use an intake pump with non return valve to prevent the pump oil from flowing back when the pump suddenly stops.
- Use the intake pump that can suction up to 666.6 Pa (5 mm Hg).

- Close the service valve of the pipe on the liquid side and on the gas side completely while performing the pressure leak test or creating vacuum.

ATTENTION:

- **if pressure increases in one hour, humidity remains inside the pipe or there is a leak.**

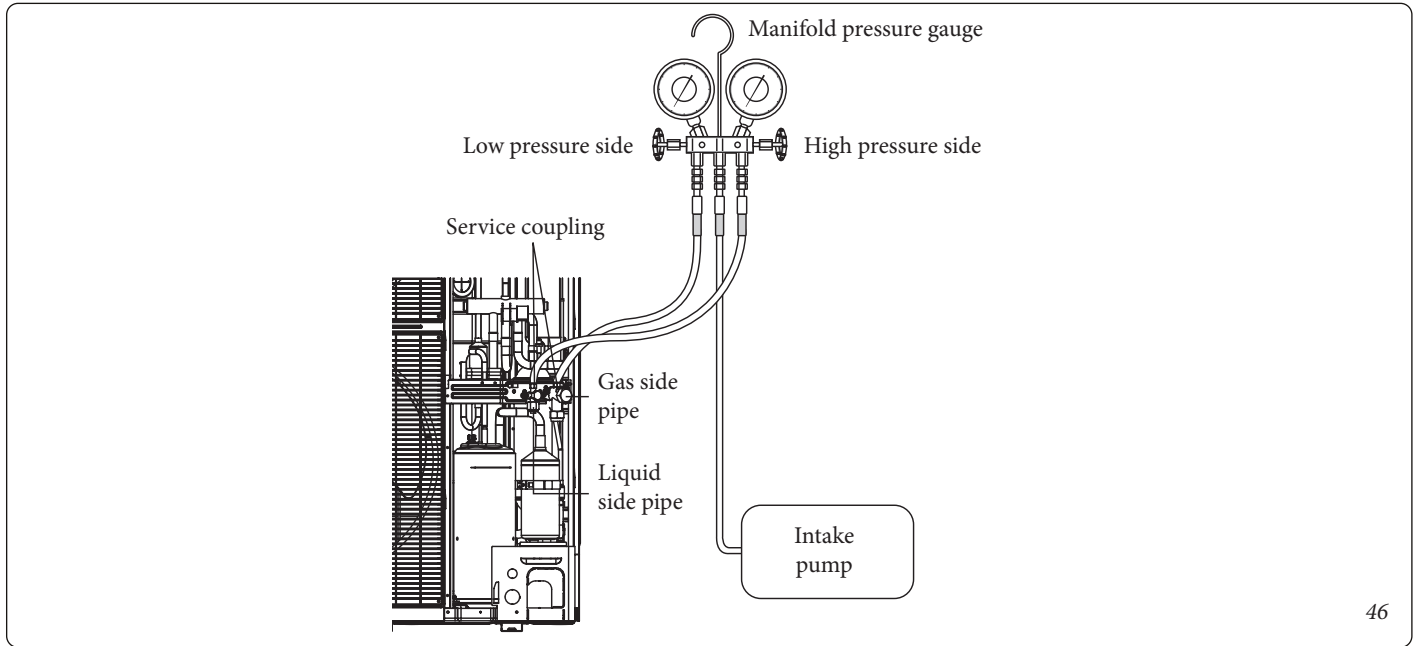

46

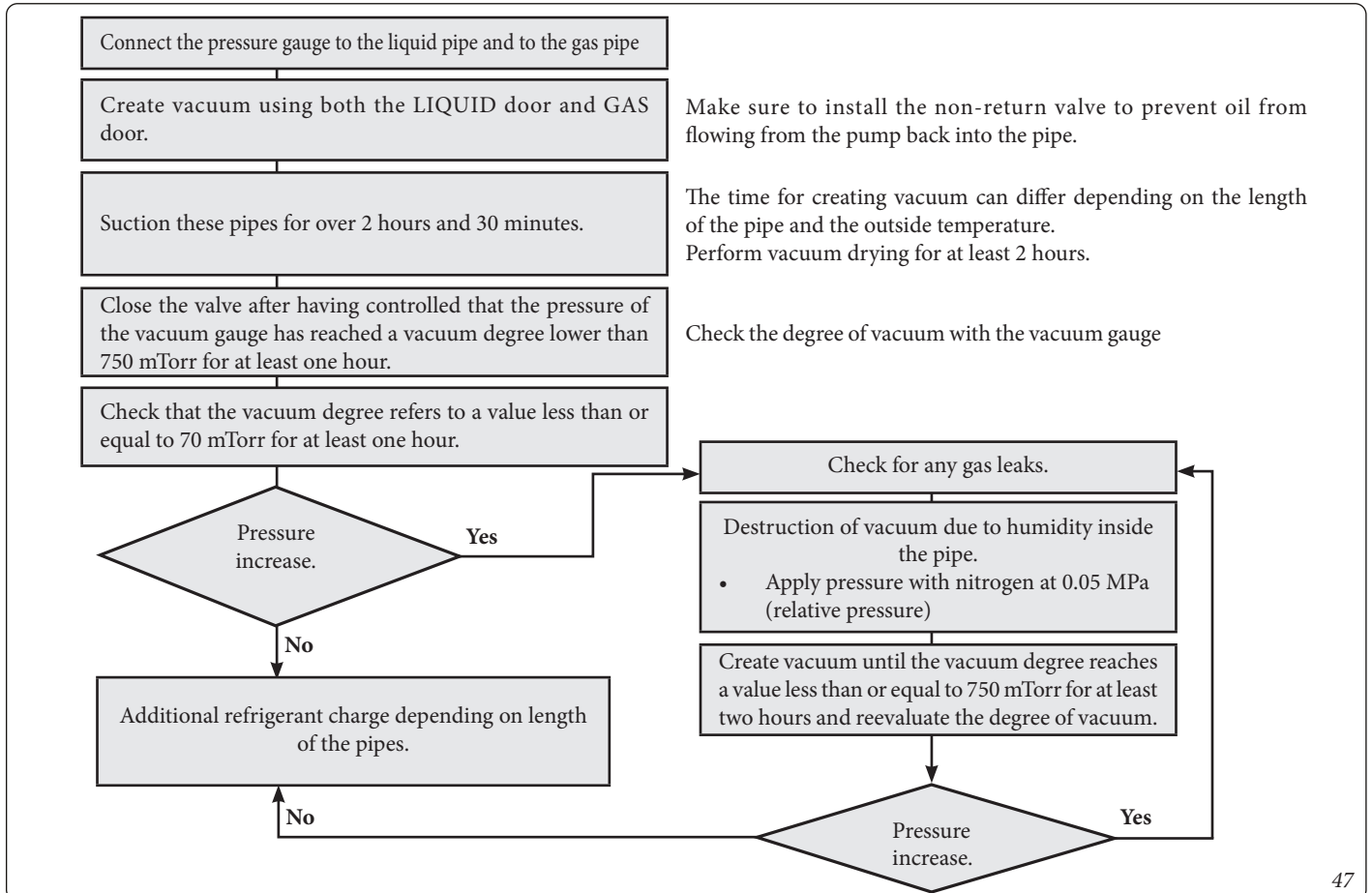

47

8.10 SELECT THE ADDITIONAL REFRIGERANT CHARGE.

Basic charge

The amount of refrigerant charged in the factory is:

Outdoor unit (series)	Charge in factory (kg)
AUDAX PRO 4 V2	1.2
AUDAX PRO 6 V2	
AUDAX PRO 9 V2	1.4

Charge another refrigerant depending on the total length of the pipe.

The factory values of each charge are determined by the basic length of the pipe of 15 m.

When an additional pipe length is necessary, further charging jobs must be implemented as described below.

Charge the refrigerant.

The additional charge value is determined based on a specifications of the liquid pipe.

Outdoor unit of the liquid	ø 6.35
additional charge (g)	20 g/m

$$\text{additional charge (g)} = (L1-15) \times 20$$

L1: Total length of the liquid pipe Ø 6.35 (m).



E.g.: Total length of the liquid pipe = 20 m.

$\Phi = 6.35 (20 \text{ m} - 15 \text{ m}) \times 20 \text{ g/m} = 100 \text{ g}$.

PRECAUTIONS ON ADDING REFRIGERANT R-32



In addition to the standard charging procedure, the following requirements must be met.

- Make sure there is no contamination by other refrigerants for charging.
- To minimise the amount of refrigerant, keep the flexible hoses and lines as short as possible.
- The cylinders must be upright.
- Make sure that the chilling system is earthed before charging.
- Label the system after charging, if necessary.
- Pay the utmost attention not to overcharge the system.
- Before charging, the pressure must be checked by blowing nitrogen.
- After the charge, check for any leaks before activation.
- Make sure that you check for leaks before leaving the work area.

8.11 RECHARGING THE REFRIGERANT.

- Measure the amount of refrigerant based on the length of liquid side pipe. Use a scale to add the proper amount of refrigerant.

Important information on standards relative to the refrigerant used.

This product contains fluorinated greenhouse gases. Do not release the gas into the atmosphere.

ATTENTION:



- inform the user if the system contains 5 tCO₂e or more of fluorinated greenhouse gases. In this case, a leak test must be carried out once every 12 months, in compliance with regulation No. 517/2014. This job must be carried out by professionally qualified technical personnel only. In the situation considered above, the installer (or authorised person in charge of the final control) must draft a maintenance booklet containing all of the information prescribed in REGULATION (EU) No. 517/2014 OF THE EUROPEAN PARLIAMENT AND OF THE COUNCIL of 16 April 2014 on fluorinated greenhouse gases.

- Before charging, check whether or not there is a siphon is attached on refrigerant cylinder and position the cylinder accordingly (see figures 48-49).

ATTENTION:



- the compiled label must be applied near the product load door (for example on the inner side of the casing of the stop valve).
- Make sure that the total refrigerant charge does not exceed (A), the maximum refrigerant charge, which is calculated with the following formula: Maximum refrigerant charge (A) = refrigerant charge (B) + maximum additional refrigerant charge due to extension of the piping (C).
- The following table summarises the refrigerant charge limits for each product.

Model	Unit	A	B	C
AUDAX PRO 4-6 V2	g	1500	1200	300
AUDAX PRO 9 V2		1800	1400	400

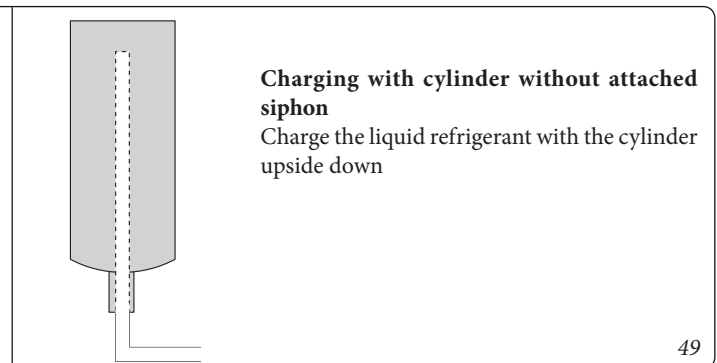
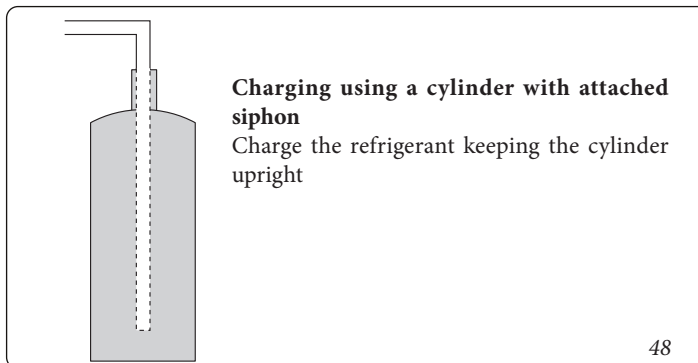

R-32
GWP = 675

Fill in the following form with indelible ink on the refrigerant charge label supplied with this product and on this manual.

- 1 = refrigerant charge of product in factory.
- 2 = amount of additional refrigerant charged on-site.
- 1+2 = total refrigerant charge

- a. Charge product refrigerant in factory: See rating plate.
- b. Amount of additional refrigerant charged on-site. (Refer to the information below for the amount of refrigerant charge).
- c. Total refrigerant recharge.
- d. Refrigerant cylinder and charge manifold.

Unit	Kg	tCO ₂ e
(1), a		
(2), b		
(1) + (2), c		

Type of refrigerant	GWP value
R-32	675

GWP: Global Warning Potential
Calculation tCO₂e: kg x GWP / 1000

8.12 ADDING REFRIGERANT.

- Measure the amount of refrigerant based on the length of liquid side pipe. Use a scale to add the fixed amount of refrigerant
- Connect the pressure gauge to the manifold and bleed the manifold.
- Open the manifold pressure gauge valve of the liquid side service valve and add refrigerant liquid.
- If it is not possible to completely recharge the additional refrigerant, while the outdoor unit is stopped, use the key on the PCB of the outdoor unit to recharge the remaining refrigerant.
- **Adding refrigerant in cooling**
 - 1) Press the function key to add refrigerant in cooling mode.
 - 2) Open the valve on the gas side after 20 minutes of operation.
 - 3) Open the valve on the low-pressure side of the manifold pressure gauge to recharge the remaining refrigerant.

- Adding refrigerant in heating

- 1) When recharging the refrigerant in heating, connect the low-pressure pipe from the manifold pressure gauge to the recharge intake door.
- 2) Press the function key to add refrigerant in heating mode.
- 3) Open the valve on the recharge intake door after 20 minutes of operation.
- 4) Open the valve on the low-pressure side of the manifold pressure gauge to recharge the remaining refrigerant.

ATTENTION:



- **open the gas side and liquid side service valve completely after charging the refrigerant. (If the condensing unit is used with the service valve closed, important parts could be damaged).**

Adding refrigerant in cooling conditions

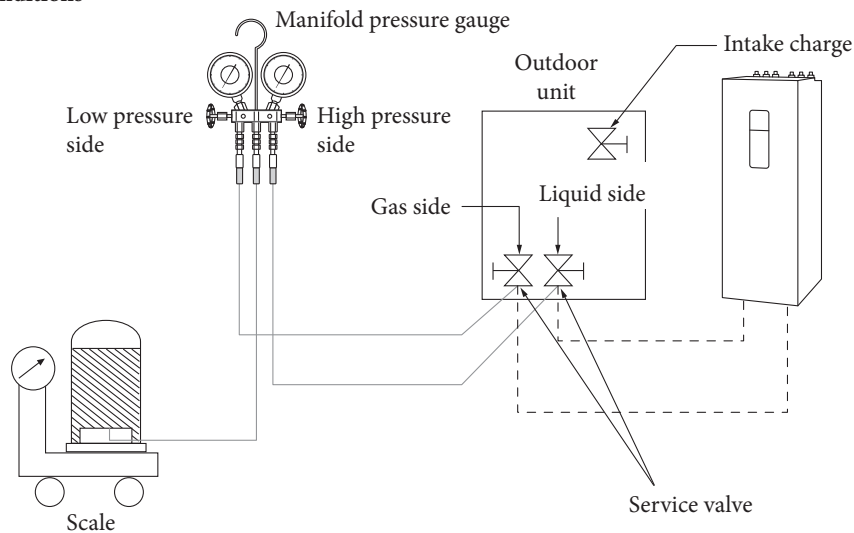

Adding refrigerant in heating conditions

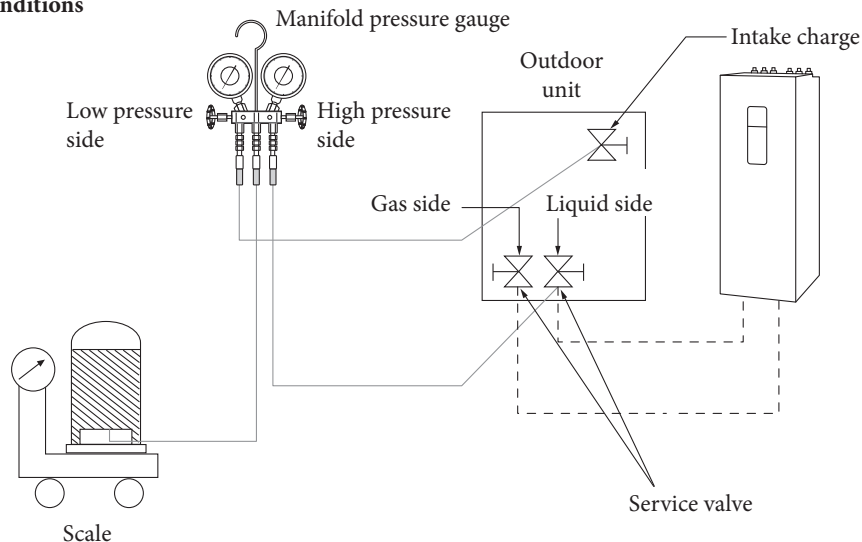

8.13 CLOSING THE VALVE STEM.

1. Open the cap and turn the valve stem clockwise using a hex key (see figure 52).
2. Tighten the valve stem until the sealing edge is reached.

- Do not overtighten the valve stem and always use special tools. Otherwise the contact surface between the valve stem and sealing edge could be damaged and refrigerant could leak through this damaged surface.
- If refrigerant leaks, turn the valve stem halfway back and re-tighten, then check the leak. If there is no more leak, tighten the entire valve stem.



3. Firmly tighten the cap.

8.14 OPENING THE VALVE STEM.

1. Remove the cap.
2. Turn the valve stem anticlockwise using a hex key.
3. Turn the valve stem until it stops.
4. Firmly tighten the cap.

ATTENTION:



- when using the service coupling, always use a recharge pipe.
- Check for refrigerant gas leakage after tightening the cap.
- Use an open end spanner and an adjustable spanner when opening/tightening the valve stem.

Outside diameter (mm)	Tightening torque (N·m)		Operating torque (N·m)
	Body cap	Recharge door cap	Stem
ø 6.35	20 ~ 25	10 ~ 12	Max 5
ø 15.88			

* 1 N·m = 10 kgf·cm

9 COOLING CYCLE DIAGRAMS.

9.1 AUDAX PRO 4-6 V2 DIAGRAM.

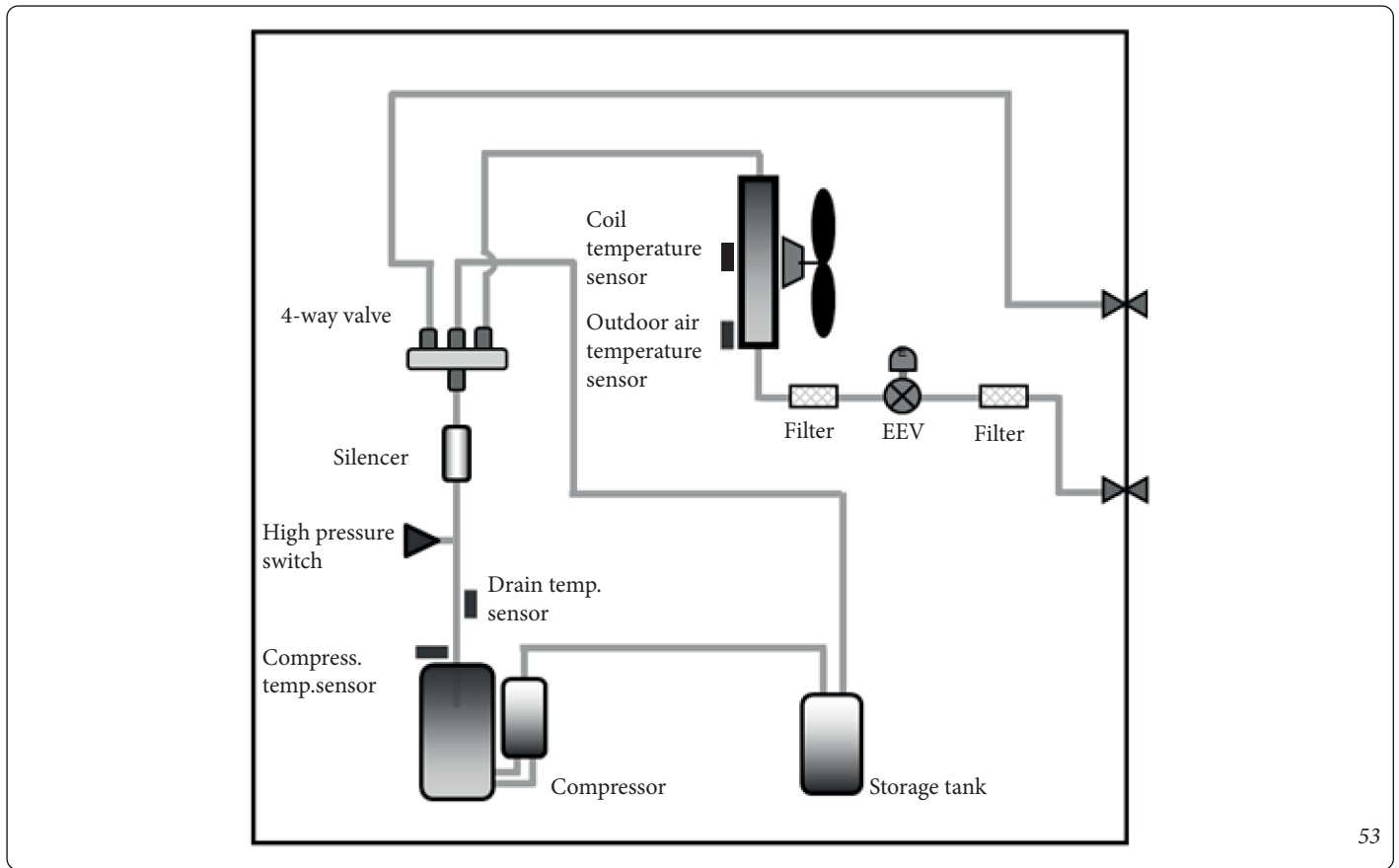

53

9.2 AUDAX PRO 9 V2 DIAGRAM.

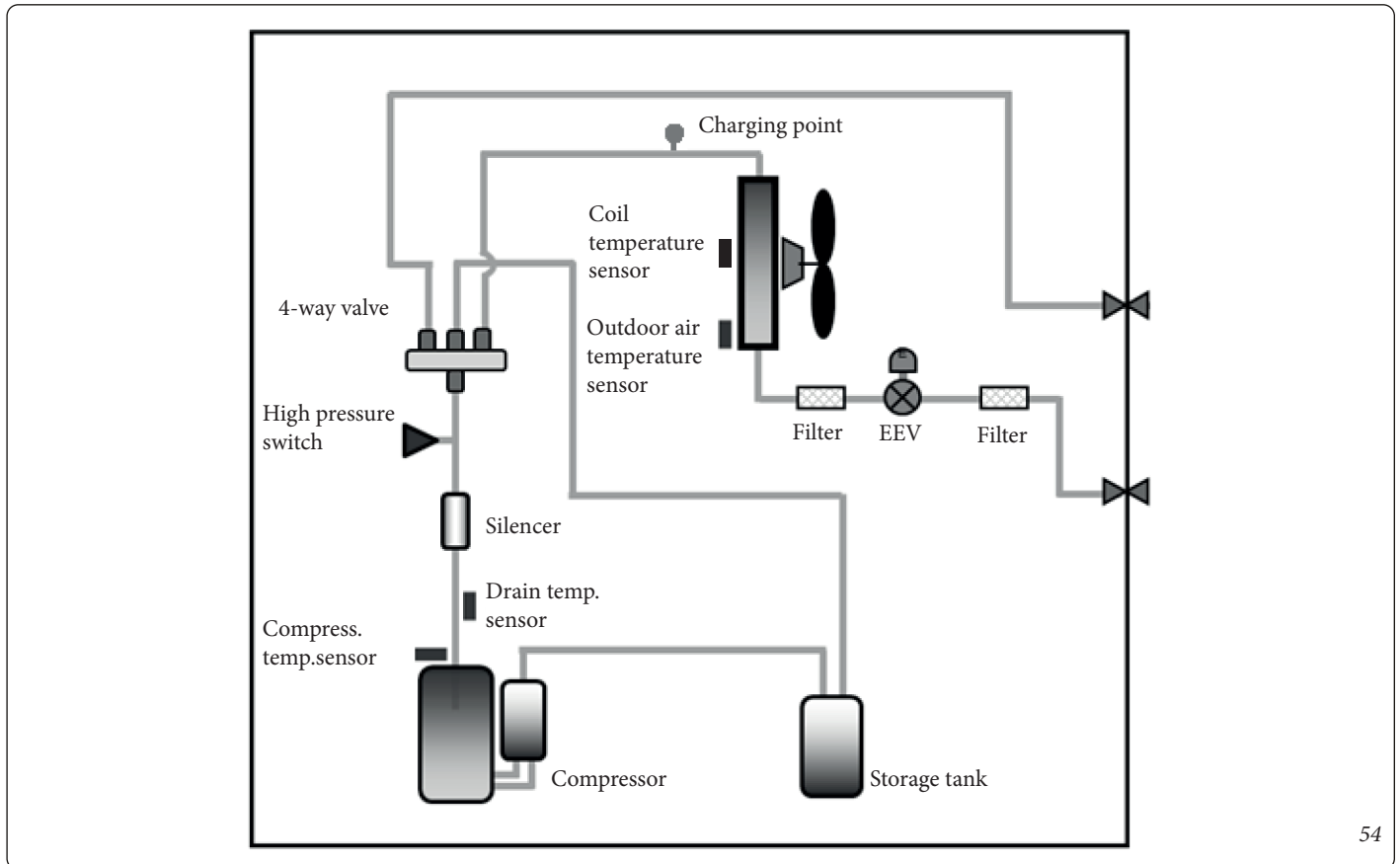

54

10 WIRING DIAGRAMS.

10.1 AUDAX PRO 4-6 V2 WIRING DIAGRAM.

Colour code key:
 BLK - Black
 RED - Red
 BLUE - Blue
 WHT - White
 YELLOW - Yellow
 BRN - Brown
 SKY - Sky blue
 GRN - Green

Key:
 A - Optional
 B - Thermistor value:
 25°C (77°F) at 10k Ω
 25°C (77°F) at 200k Ω
 C - Reactor
 D - Download
 E - Inverter board
 F - Eco download
 G - Eco comm
 H - Hot gas
 I - EMI filter
 L - Internal comm
 M - Main AC power supply
 N - Earth
 O - H pressure switch
 P - Dred PCB
 Q - 4 way
 R - Dred 1, 2, 3

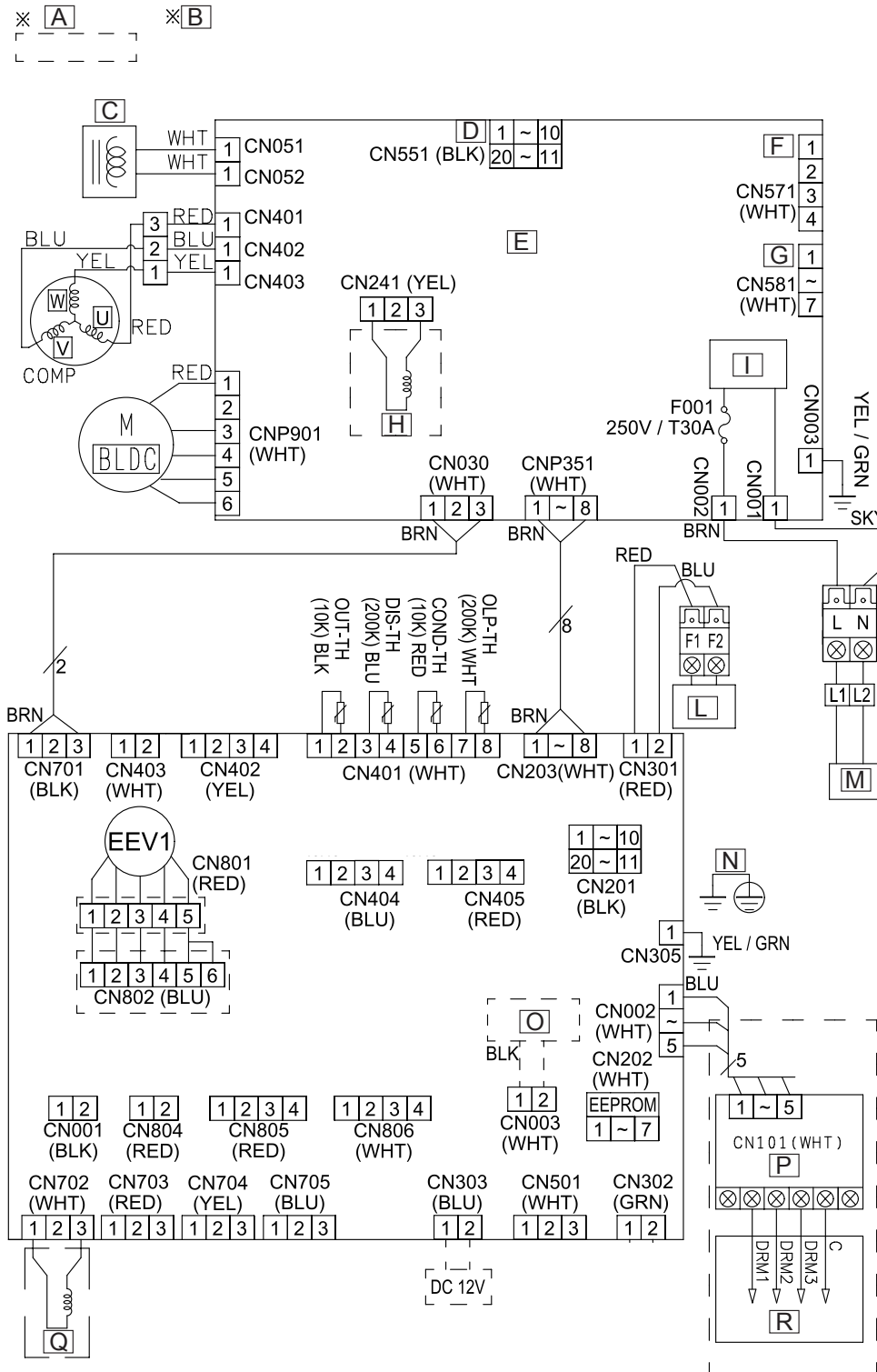

10.2 AUDAX PRO 9 V2 WIRING DIAGRAM.

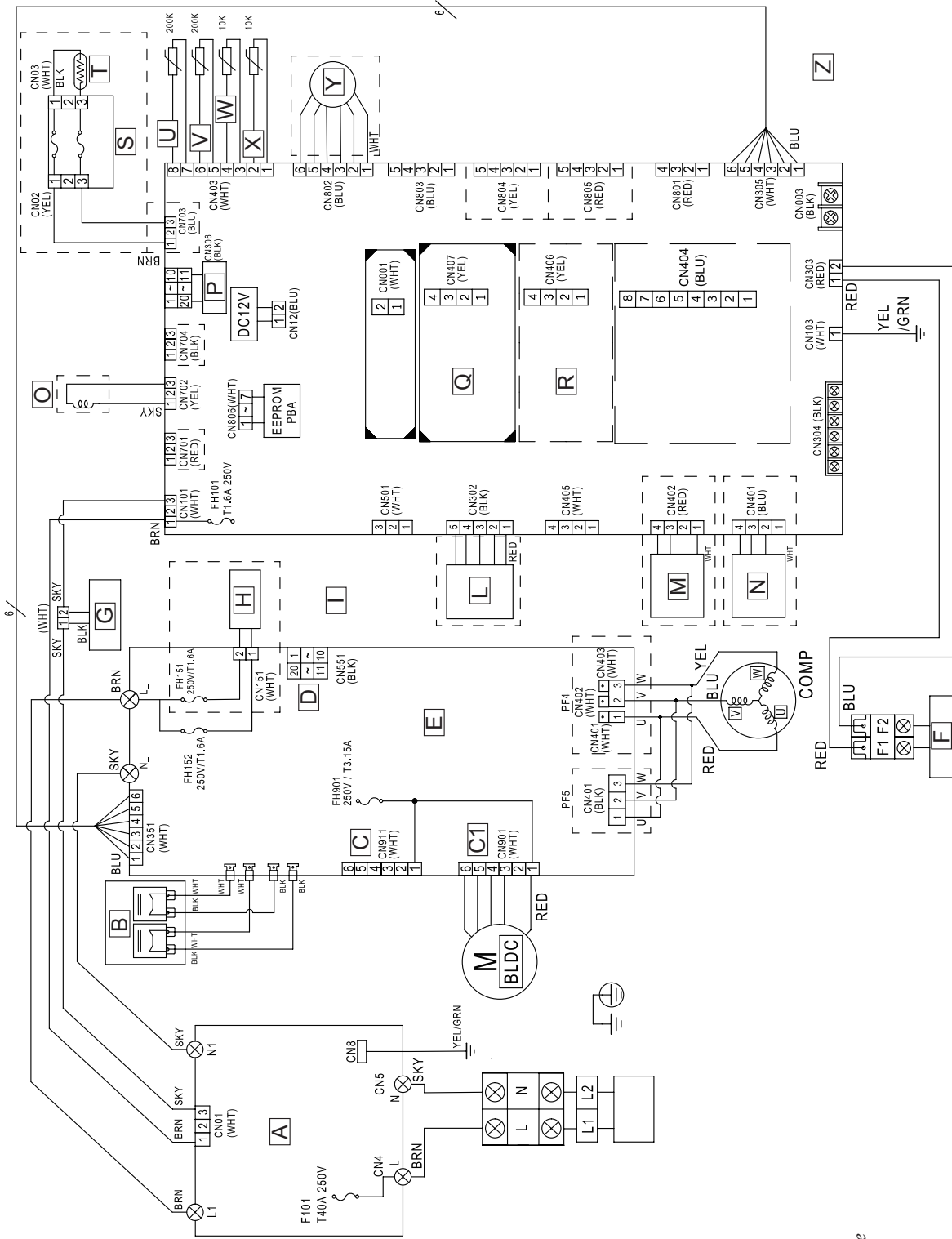

Colour code key:
 BLK - Black
 RED - Red
 BLUE - Blue
 WHT - White
 YELLOW - Yellow
 BRN - Brown
 SKY - Sky blue
 GRN - Green

Key:

- A - EMI board
- B - Reactor
- C - Fan 2
- C1 - Fan 1
- D - Download inverter
- E - Inverter board
- F - Internal comm
- G - High pressure switch
- H - High pressure switch
- I - Table 1:
 1 external fan - blue pipe
 2 external fan - white pipe
- L - Comm-optional
- M - High pressure sensor
- N - Low pressure sensor
- O - 4 way - I
- P - Download
- Q - Water inlet/outlet
 (25°C, 77°F, 10K)
- R - Pipe/intake diam. (25°C,
 77°F, 10K)
- S - PBA basic heater
- T - Heater
- U - OLP temperature
- V - Drain temperature
- W - Air-conditioner temperature
- X - Outside temperature
- Y - Main EEV
- Z - *25°C (77°F) at 10k ohm
 25°C (77°F) at 200k ohm

11 MICROSWITCH AND KEY FUNCTION SETTINGS.

11.1 AUDAX PRO 4-6 V2 TESTING OPERATIONS.

1. Check the supply voltage between the outdoor unit and the auxiliary switch.

- Single phase power supply: L, N

2. Check that the power and communication cables have been connected properly. (If the power and communication cables are mixed or connected improperly, the PCB will be damaged).
 3. Press K1 or K2 on the outdoor unit board to execute the test mode and to interrupt (for the operating conditions of the indoor unit, see the relative booklet).

KEY	Operations on KEY	7-segment display
K1	Press once: Execution of heating test	"8" "1" "EMPTY" "EMPTY"
	Press twice: Execution of the defrost test	"8" "3" "EMPTY" "EMPTY"
	Press 3 times: End of test mode	-
K2	Press once: Execution of cooling test (heating only: skip)	"8" "2" "EMPTY" "EMPTY"
	Press twice: Execution of outlet signal test	"8" "4" "EMPTY" "EMPTY"
	Press 3 times: End of test mode	-
K3	Reset	-
K4	View mode	Refer to display in view mode

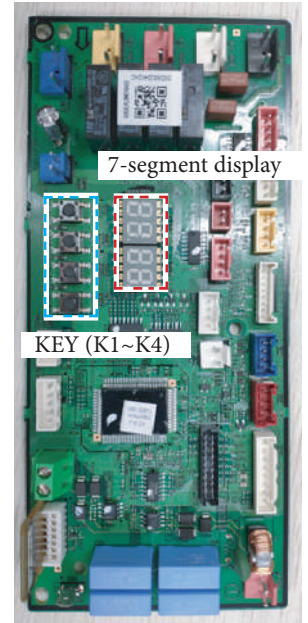

4. View mode: pressing K4, allows you to view information on the status of the system, as follows (in Test stage it is not possible to use the key K4).

Number of times pressed	Contents viewed	Display				Unit
		Segment 1	Segment 2	Segment 3	Segment 4	
0	Communication status	10th digit of Tx	1st digit of Tx	10th digit of Rx	1st digit of Rx	-
1	Requested frequency	1	100th digit	10th digit	1st digit	Hz
2	Current frequency	2	100th digit	10th digit	1st digit	Hz
3	-	3	100th digit	10th digit	1st digit	%
4	Outdoor air temp.	4	+/-	10th digit	1st digit	°C
5	Compress. drain temp.	5	100th digit	10th digit	1st digit	°C
6	Liquid phase sensor	6	+/-	10th digit	1st digit	°C
7	Indoor unit return temp.	7	+/-	10th digit	1st digit	°C
8	Indoor unit flow temp.	8	+/-	10th digit	1st digit	°C
9	Battery temp.	9	+/-	10th digit	1st digit	°C
10	Inverter current	A	10th digit	1st digit	First decimal	A
11	Fan RPM	B	1000th digit	100th digit	10th digit	rpm
12	Drain temperature target	C	100th digit	10th digit	1st digit	°C
13	EEV	D	1000th digit	100th digit	10th digit	passage
14	Protection control	E	0: Cooling 1: Central heating	Protection control 0: No protection control 1: Freezing 2: Defrosting 3: Overload 4: Supply 5: Total current	Frequency status 0: Normal 1: Maintained 2: Down 3: Upper_limit 4: Lower_limit	-
15	Inverter temp.	F	+/-	10th digit		°C
long -1	Main board version	Year (Decimal)	Month (Hexadecimal)	Day (Two digits)	Day (One digit)	-
long -1 and 1	Inverter board version	Year (Decimal)	Month (Hexadecimal)	Day (Two digits)	Day (One digit)	-
long -1 and 2	EPROM version	Year (Decimal)	Month (Hexadecimal)	Day (Two digits)	Day (One digit)	-

5. Setting of the key function.



11.2 AUDAX PRO 9 V2 TESTING OPERATIONS.

1. Check the supply voltage between the outdoor unit and the auxiliary switch.

- Single phase power supply: L, N

2. Check that the power and communication cables have been connected properly. (If the power and communication cables are mixed or connected improperly, the PCB will be damaged).

3. Press K1 or K2 on the outdoor unit board to execute the test mode and to interrupt (for the operating conditions of the indoor unit, see the relative booklet).

KEY	Function of BUTTONS	7-segment display
K1	Press once: Operating test in central heating	"8" "1" "BLANK" "BLANK"
	Press twice: Operating test in defrosting	"8" "3" "BLANK" "BLANK"
	Press 3 times: End the test mode	-
K2	Press once: Cooling operation test (heating only: skip)	"8" "2" "BLANK" "BLANK"
	Press twice: Signal emission operating test	"8" "4" "BLANK" "BLANK"
	Press 3 times: End the test mode	-
K3	Resetting	-
K4	View mode	Refer to view mode

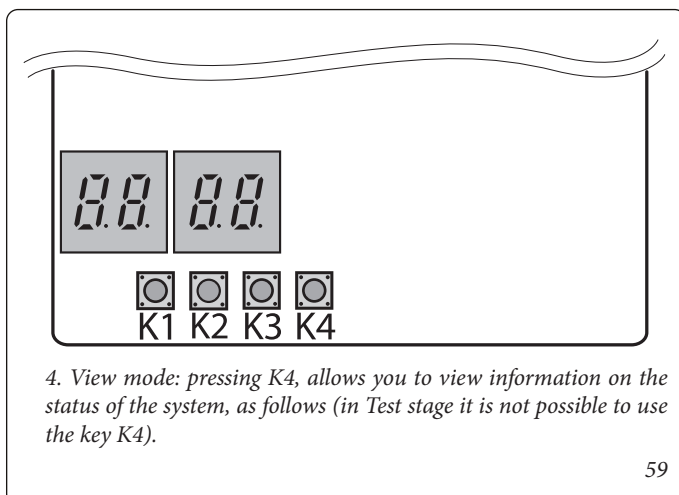
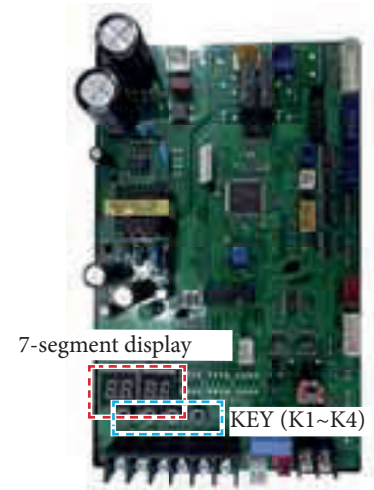

Number of times pressed	Contents viewed	Display				Unit
		Segment 1	Segment 2	Segment 3	Segment 4	
0	Communication status	Digit of Tx tens	Digit of Tx units	Digit of Rx tens	Digit of Rx units	-
1	Requested frequency	1	Digit of hundreds	Digit of tens	Digit of units	Hz
2	Current frequency	2	Digit of hundreds	Digit of tens	Digit of units	Hz
3	-	3	Digit of hundreds	Digit of tens	Digit of units	%
4	Outdoor air temp.	4	+/-	Digit of tens	Digit of units	°C
5	Compress. drain temp.	5	Digit of hundreds	Digit of tens	Digit of units	°C
6	Liquid phase sensor	6	+/-	Digit of tens	Digit of units	°C
7	Indoor unit return temp.	7	+/-	Digit of tens	Digit of units	°C
8	Indoor unit flow temp.	8	+/-	Digit of tens	Digit of units	°C
9	Battery temp.	9	+/-	Digit of tens	Digit of units	°C
10	Inverter current	A	Digit of tens	Digit of units	First decimal	A
11	Fan RPM	B	Digit of thousands	Digit of hundreds	Digit of tens	rpm
12	Drain temperature target	C	Digit of hundreds	Digit of tens	Digit of units	°C
13	EEV	D	Digit of thousands	Digit of hundreds	Digit of tens	phase
14	Protection control	E	0: Cooling 1: Central heating	Protection control 0: No protection control 1: Freezing 2: Defrosting 3: Overload 4: Drain 5: Overall current	Frequency status 0: Normal 1: Pending 2: Low 3: High_limit 4: Low_limit	-
15	Inverter temp.	F	+/-	Digit of tens		°C
long-1	Main board version	Year (Decimal)	Month (Hexadecimal)	Day (Two digits)	Day (One digit)	-
long-1 and 1	Inverter board version	Year (Decimal)	Month (Hexadecimal)	Day (Two digits)	Day (One digit)	-
long-1 and 2	EPROM version	Year (Decimal)	Month (Hexadecimal)	Day (Two digits)	Day (One digit)	-

5. Set the key functions.



Setting of the option.

1. Press and hold K2 to enter the option setting. (Only available when the operation is interrupted)

- If the option setting is entered, the display appears as follows.

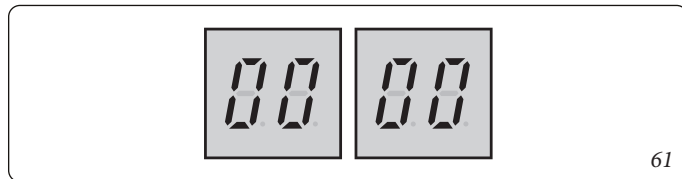

- Seg1 and Seg2 will show the number of the selected option.

- Seg3 and Seg4 will show the number of the set value of the selected option.

2. If the option setting has been entered, you may briefly press the switch K1 to adjust the value of Seg1, Seg2 and to select the desired option.

(Example):

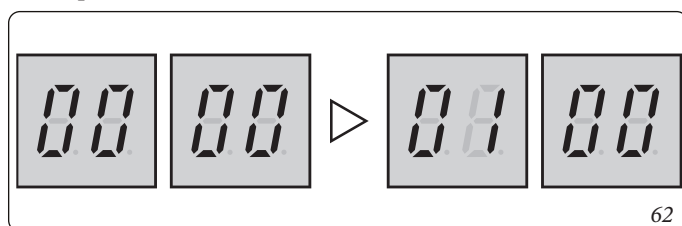

3. If you selected the desired option, you may briefly press the switch K2 to adjust the value of Seg3, Seg4 and to modify the function of the desired option.

(Example)

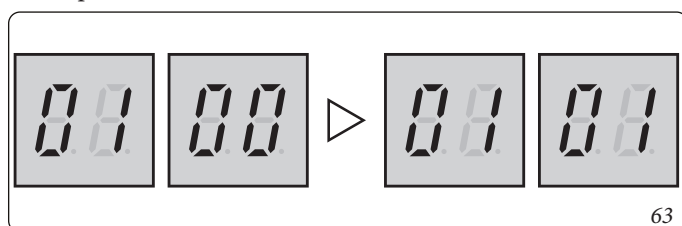

4. After having selected the function of the options, press and hold the switch K2 for 2 seconds. The modified value of the option will be saved when whole segments flash and mode monitoring begins.

ATTENTION:



- the modified option will not be saved if you do not finish setting the option as explained above.

- While setting the option, you may press and hold the key K1 to reset the previously set value.

- If you want to restore the default settings, press and hold the key K4 while setting the options.

- Holding down the key K4 restores the default settings, though it does not save them. Press and hold the key K2. When the segments show that monitoring mode is in progress, the setting will be saved.

Option	Inlet unit	SEG1	SEG2	SEG3	SEG4	Option function
Snow accumulation prevention check	Main	0	3	0	0	Deactivated
				0	1	(default setting) Activated
Silent mode	Main	0	4	0	0	Manual silent mode (-3 dB)
				0	1	Manual silent mode *0.9 (-5 dB)
				0	2	Manual silent mode *0.75 (-7 dB)
				0	3	Manual silent mode (-3 dB)
				0	4	Low noise silent mode (default)

12 “PUMP DOWN” EXECUTION.

12.1 PURPOSE OF “PUMP DOWN”.

To repair products and transfer the indoor unit, the pump down operation can be made to recover the refrigerant in the outdoor unit.

In particular for product repairs, it is recommended to store the refrigerant in a cylinder, using a recovery unit (see current legislation in the country of destination).

12.2 IMPORTANT WARNINGS FOR “PUMP DOWN” EXECUTION.

- The slim design of the product limits the amount of refrigerant in the outdoor unit.
 - Collect the majority of the system's refrigerant in a cylinder approved for refrigerant recovery and perform pump down for the remaining refrigerant. The maximum amount of refrigerant is 1.8 kg.
 - If the refrigerant exceeds the maximum allowed limit, a pressure increase could cause a compressor error or its failure.
1. Close the pressure gauge.
 2. Activate the unit in cooling test mode by pressing the button K2 once.
 3. When the compressor has been running for 5 minutes, close the service valve on the liquid side.
 4. Observe the low-pressure side using a pressure gauge unit.
 5. When the pressure gauge reads “0”, close the valve on the low-pressure side by turning it clockwise.
 6. Press K3 to interrupt the operation of the unit.
 7. Close each cap of the valves.

ATTENTION:

- **use a cylinder approved for recovery when recovering the refrigerant to be reused. Using a modified vessel for the refrigerant can cause explosions and personal harm or injury.**



Repositioning the condensing unit.

- Refer to this procedure when transferring the unit.
- Perform the pump down procedure. (Refer to the pump down details.)
- It can be difficult to recover the refrigerant when the recharged amount exceeds the standard amount to support long pipes. (See page 34).
- Remove the power cable. • Disconnect the assembly cable from the indoor and outdoor unit. • Remove the countersunk nuts which connect the indoor unit and piping.
- Then cover the pipes of the indoor unit and the other pipes with a vinyl plug or cap to keep foreign material out.
- Detach the pipes connected to the outdoor unit. Then cover the pipes of the outdoor unit and the other pipes with a vinyl plug or cap to keep foreign material out.
- Make sure not to bend the connection pipes in the middle and to put them back with the cables.
- Move the indoor and outdoor units to the new position.
- Remove any installation accessories of the indoor unit and move it to the new position.



ATTENTION:

- **before moving the unit, be sure to carefully read how to recover the refrigerant on page 13.**
- **While recharging refrigerant R-32 when it was completely emptied, make sure to charge only the amount a refrigerant charged in the factory.**
- **When you open the cooling circuit, make sure to have reached a good degree of vacuum before charging the refrigerant.**
- **Use an electronic scale to measure the amount of refrigerant, and make sure that only the indicated amount is charged.**



ATTENTION:

- **if more refrigerant than that specified on the label is charged, there is a risk of fire due to refrigerant leaks.**



12.3 COLLECT THE REFRIGERANT IN A SPECIFIC VESSEL BEFORE “PUMP DOWN”.

If the amount of refrigerant in the system exceeds the maximum allowed limit, reduce the amount of refrigerant by following the instructions below before performing the pump down operation.

1. Prepare a cylinder approved for refrigerant recovery, a scale and a pressure gauge.
2. Check the amount of refrigerant in the entire system.
3. Connect the recovery cylinder to the outdoor unit and manage the indoor unit in cooling mode.
4. After 10 minutes of operation in cooling mode, check the pressure on the high-pressure side using the pressure gauge. If the pressure on the high-pressure side is higher than 3.0 MPa (30.59 kgf/cm²), approach the water setpoint to drop the pressure below 3.0 MPa (30.59 kgf/cm²).
5. When the pressure drops below 3.0 MPa (30.59 kgf/cm²) open the valve of the pressure gauge (2) which is connected to the liquid side. Then open the valve on the refrigerant vessel to transfer the refrigerant from the liquid side pipe to the vessel.
6. Use the scale to check the weight difference. When the desired amount of refrigerant is collected in the recovery cylinder, close the valve and remove the manifold pressure gauge.
7. Make sure that about half the refrigerant of the entire system is collected in the recovery cylinder.
8. Correctly measure the amount of refrigerant so as not to exceed the collected amount.

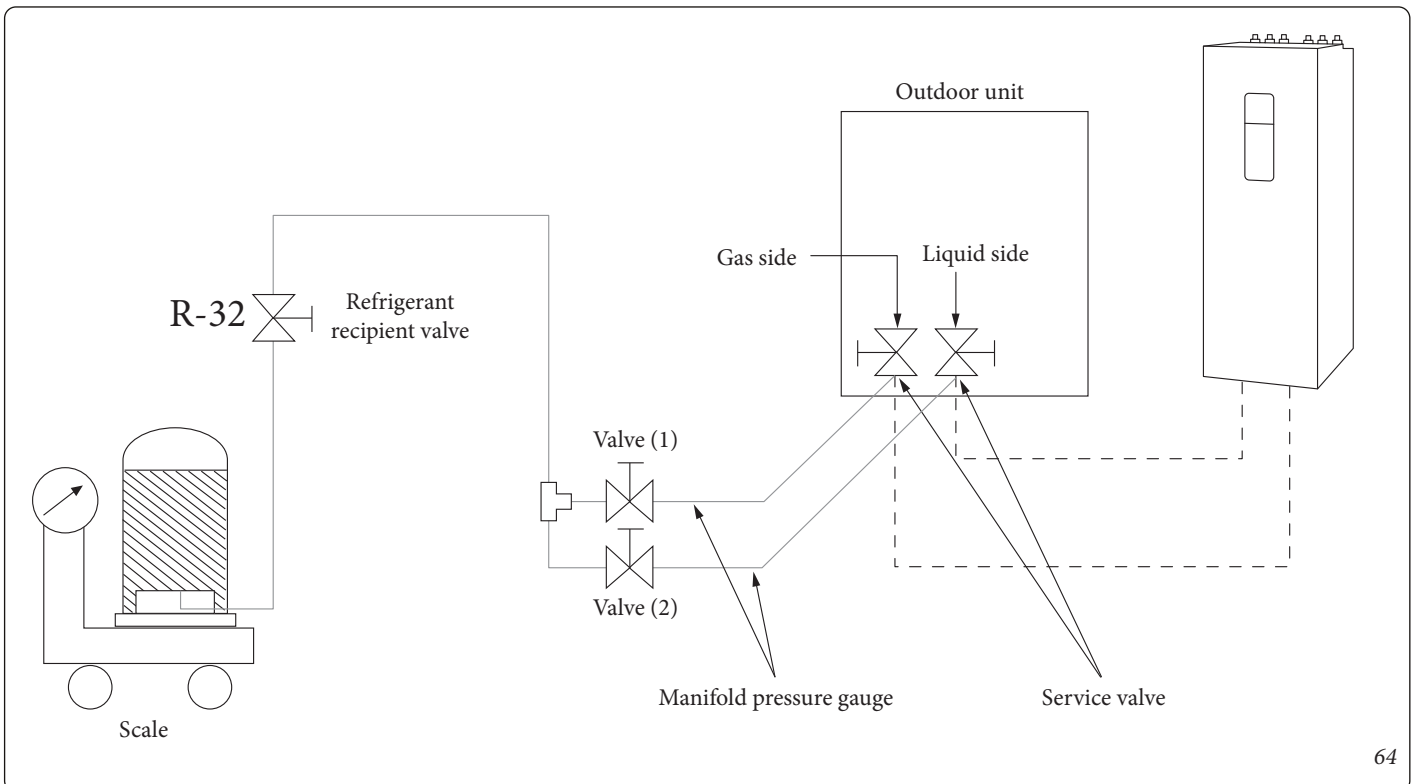

13 COMPLETION OF INSTALLATION.

- Check the following after having completed the installation.

Installation	Outdoor unit	<ul style="list-style-type: none"> - Check the external surface and the inside of the outdoor unit. - Is a short-circuit possible? - Is the position well ventilated and is there clearance space for assistance? - Is the outdoor unit firmly fixed?
	Indoor unit	<ul style="list-style-type: none"> - Check the external surface and the inside of the indoor unit. - Is the position well ventilated and is there clearance space for assistance? - Check whether the centre of the indoor unit is fixed and if it is installed horizontally
Adding refrigerant		<ul style="list-style-type: none"> - Are the length and difference between the refrigerant pipes within the admissible range? - Is the pipe suitably insulated? - Has the amount of additional refrigerant been weighed correctly?
Installation of drain pipe		<ul style="list-style-type: none"> - Check the drain pipe of the outdoor unit and of the indoor unit. - Was the drain test completed? - Is the drain pipe suitably insulated?
Perform the wiring		<ul style="list-style-type: none"> - Was the outdoor unit earthed 3? - Is a 2-wire cable used? - Is the length of the wire within the limited range? - Is the wiring path correct?

14 FINAL INSPECTIONS AND TEST OPERATION.

14.1 INSPECTION PRIOR TO TEST OPERATION.

1. Check the power cable and the communication cable of the indoor unit and outdoor unit.
2. Check the supply voltage between the outdoor unit and the electric panel.
 - Check the voltage at 220-240 V ac ~ using a voltmeter.
3. Once the outdoor unit has been switched on, perform monitoring to verify that the indoor unit is connected and check the options.

14.2 TEST OPERATION.

1. Run the unit by means of the indoor unit.

- Check the sound of the compressor during initial operation. Stop it if it makes a screeching noise.

2. Check the operating status of the indoor and outdoor units

- Anomalous operating noise of the indoor and outdoor unit.
- Correct drainage of the indoor unit in cooling mode.

3. End of the test.

4. Explain to the customer how to use the condensing unit following the user manual.

AUDAX PRO 4 V2 - AUDAX PRO 6 V2

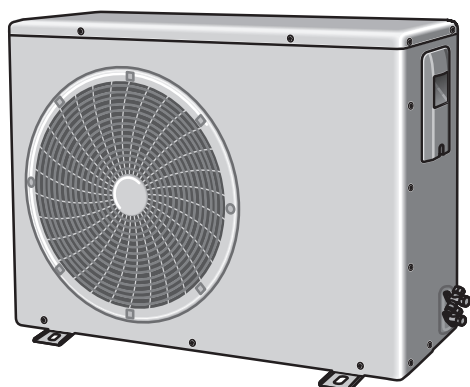

65

AUDAX PRO 9 V2

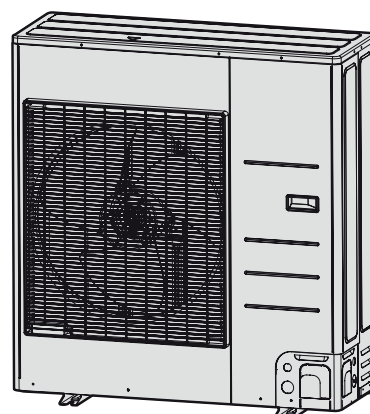

66



This instruction booklet
is made of ecological paper

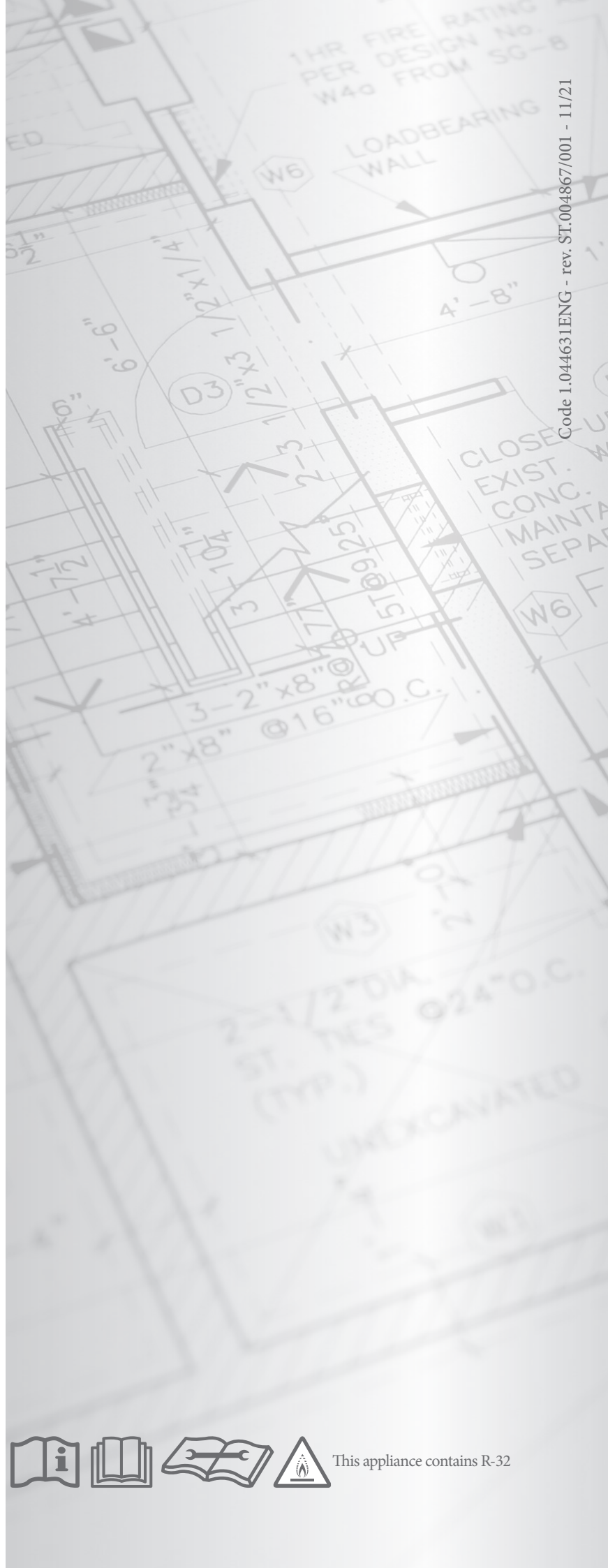

Code I.044631ENG - rev. ST.004867/001 - 11/21



immergas.com

Immergas S.p.A.
42041 Brescello (RE) - Italy
Tel. 0522.689011
Fax 0522.680617



This appliance contains R-32