

CONDENSING

 **IMMERGAS**

1964 - 2014 50th ANNIVERSARY



NEW RANGE

VICTRIX TT RANGE

Wall-hung combi
and only-heating
condensing boiler



50th
1964 2014
BOILER





 **IMMERGAS**





50th

1964 2014

Immergas. Our long story teaches us always to look to the future.

The **5th of February 1964** saw the birth of Immergas out of an inescapable desire to come up with ideas and reliable products in the Italian style. Products designed to last that would improve people's lives. Today, for the thousands of engineers and employees who work and cooperate with us, nothing has changed. We are present in over 40 countries with 9 branches in Europe and one in China, we have partnerships with the most important distribution companies across the globe, yet **we keep on investing** in facilities, plants, and technologies with the selfsame spirit.

On account of the same business idea we insist on developing our designs and **paying more attention to the environment and consumption** through new technologies. This same enthusiasm means that we continue to reaffirm day after day the importance of collaborating with those who sell, install and offer assistance to look after Immergas products and above all our end customers.

Nowadays, just like 50 years ago, our profoundest thoughts go out to them with the intention of contributing to a better future made up of comfort, safety, reliability, and environmental friendliness.



VICTRIX TT RANGE

Advanced technology made in Italy

VICTRIX TT - the boiler that symbolizes Immergas's 50th anniversary – starts a **generation of boilers designed for new installations and especially for replacement of existing system**. The entire range has been designed to anticipate the latest European Directives on energy consumption, with increasing application of condensing technology, for easier achievement of high efficiency classes in home heating and domestic hot water production.

The letters TT stand for **“Top Tech”, the ultimate technology**. VICTRIX TT is produced in the new high-automation lines of the company's original headquarters in Brescello and features an **innovative condensing unit that guarantees outstanding flow rate and head in the heating circuit, low clogging risk** from system impurities and greater resistance to corrosion thanks to the special alloy used for construction.

To further reduce consumption, we have introduced a new circuit board that modulates boiler power up to 15%: an ideal condition for in-between seasons or reduced loads. In addition to its extremely low impact on the environment, this boiler features an advanced, user-friendly interface with adjustment knobs, selection buttons and LCD display showing operation status and error codes. There are three different versions of VICTRIX TT: one combi and two for heating only.





DOMINUS. THE APP FOR ONLINE BOILER CONTROL

VICTRIX TT is the first Immergas range that can be remotely controlled through the new DOMINUS app (**available in 2015**). **The simple, intuitive app can be used to control the boiler or display its operation on a tablet, smartphone and portable PC.** You simply need to install the optional Wi-Fi transmitter kit inside the dashboard to communicate from anywhere with the boiler's circuit board.

VICTRIX TT can be combined with other remotely-controlled heat regulation systems: CAR^{V2}, the external probe and accessories for compatibility with renewable energy sources such as the solar collector probe and the integrated system controller with heat pump.

SERVICE BEYOND THE PRODUCTS

Immergas believes in excellent service as a strategy for gaining the confidence of customers, ensuring a high level of satisfaction and winning over new markets.

The extensive worldwide technical service network is the crown jewel of Immergas Customer Service, ensuring qualified support for any after-sales service need.

ADVANTAGES OF DOMINUS APP

- ▶ Intuitive navigation and simple use on smartphone and tablet touchscreens
- ▶ Remote control with direct access to main system settings, such as:
 - Operation status
 - Heating/DHW temperature setting
 - Time brackets and ambient temperature (only with CAR^{V2})
 - Reception of error messages
 - Generator resetting
- ▶ Accessible for use anywhere at any time
- ▶ Easy installation
- ▶ Encrypted security access

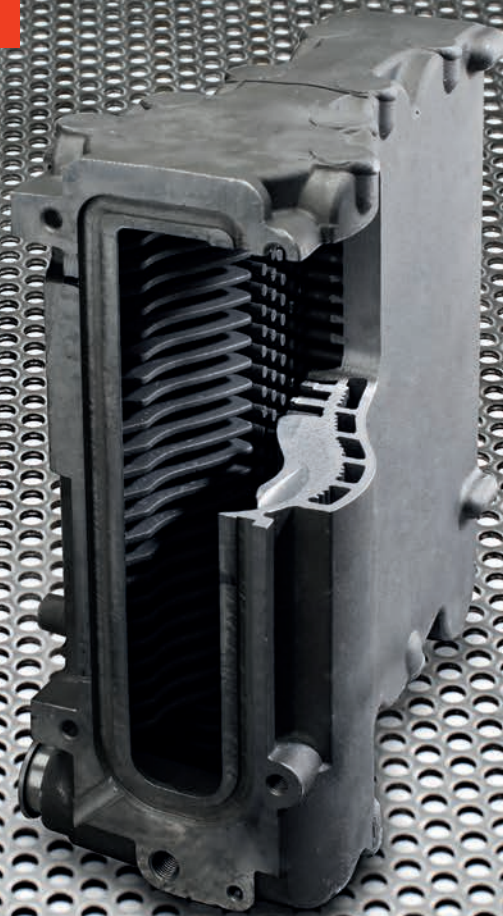

HIGH HYDRAULIC PERFORMANCE

The design of the **new condensing module features wide water passages to enable excellent flow rate and head performance** even on old heating systems. This also means reduced clogging risk when impurities are present in the water of the system.

The special aluminium-silica-magnesium alloy used for construction, together with the accessories used, makes the unit particularly resistant to corrosion. The ascending pathway of the water circuit in the exchanger flows countercurrent to the flame. The closely fitted elements increase the exchange surface ensuring high water output. It is important to keep the pH value of the water in the heating system between 6.5 and 8 and a hardness of 15 °F.

INDOOR AND OUTDOOR INSTALLATION

VICTRIX TT is approved for outdoor installation provided it is partially protected from the weather (rain and snow), for example by installing it under a balcony. An electrical resistance kit is available to expand antifreeze protection from -5 °C to -15 °C.

VERSION “X”

Two heating-only versions are available, VICTRIX 20 X TT and VICTRIX 12 X TT, **the second one in production from 2015**. Both can be **combined with a separate storage tank** unit through a special optional kit (code 3.024907). The kit consists of a motor body and connector to drive the three-way valve (standard in the boiler) and hydraulic fittings. The separate storage tank Units come in a range of models from 80 to 300 litres, to be selected according to the system requirements of domestic hot water production.



ADVANCED DESIGN

With VICTRIX TT, the research and development team at Immergas has worked to make this boiler particularly sturdy and designed to **facilitate the work of professionals**. It features new technical solutions such as:

- safety valve drain conveyed into condensate drain
- removable cover for direct access to electrical connection housing
- cover panel on hydraulic fittings to help blend boiler with room decor

WIDE MODULATION RANGE

The new circuit board reduces running costs thanks to the particularly high performance even with low energy absorption, such as during in-between seasons. **Thanks to the wide modulation range, from 15 % to 100 % heat output**, it enables high seasonal efficiency.

ELECTRONIC AIR/GAS CONTROL

The new electronic gas valve enables air/gas control by means of a multifunction electrode housed inside the combustion chamber; the circuit board self-adapts combustion parameters in case of variations in the density of air or fuel. Another important feature is that nozzles do not need to be replaced if gas is changed (methane/LPG): **the boiler is supplied as a single product code** and you simply need to make adjustments in the circuit board software.



VICTRIX 24 TT / 20 X TT

Wall-hung compact combi and heating only condensing boiler

MAIN CHARACTERISTICS

- ↘ Available 24 kW combi version and 20 kW heating-only version (a 12 kW heating-only version will be available from 2015)
- ↘ Ecofriendly - low NOx emissions (class 5)
- ↘ New condensing module with high circulation
- ↘ Modulating heat output from 15 to 100%
- ↘ Gas adaptive through control board parameters; only one product code (natural gas)
- ↘ Adjustable system by-pass
- ↘ Possible installation outdoors in partially protected areas
- ↘ Standard frost protection to -5 °C expandable to -15 °C with optional kit
- ↘ Stand-by electrical consumption < 6 W
- ↘ Green Series flue systems
- ↘ Optional hydraulic connection kit
- ↘ Storage tank connection kit for "X" models
- ↘ Same hydraulics and gas connection positions as current models



Technical data	Unit of measurement	VICTRIX 24 TT 1 E	VICTRIX 20 X TT 1 E
Code		3.024724	3.024725
CE certificate		0694CP1688	0694CP1688
Maximum nominal heat input (C.H. mode)	kW	21,3	21,3
Maximum nominal heat input (D.H.W. mode)	kW	24,6	-
Minimum nominal heat input	kW	3,1	3,1
Maximum nominal heat output (C.H. mode)	kW	20,5	20,5
Maximum nominal heat output (D.H.W. mode)	kW	23,3	-
Minimum nominal heat output	kW	3,0	3,0
Efficiency at nominal heat output (80/60 °C)	%	96,3	96,3
Efficiency at 30% of load (80/60 °C)	%	103,3	103,3
Efficiency at nominal heat output (40/30 °C)	%	104,6	104,6
Efficiency at 30% of load (40/30 °C)	%	109,1	109,1
Weighted CO with natural gas	mg/kWh	20,4	20,4
Weighted NO _x with natural gas	mg/kWh	28,0	28,0
D.H.W. flow rate for continuous service (ΔT=30 °C)	l/min	12,2	-
D.H.W. circuit max pressure	bar	10,0	-
Set heating temperature minimum (adjustable)	°C	20 - 50	20 - 50
Set heating temperature maximum (adjustable)	°C	55 - 85	55 - 85
Central heating circuit max pressure	bar	3,0	3,0
Central heating expansion vessel capacity	litres	8,0	8,0
Fan available head (max/min)	Pa	152/71	152/71
Electric protection index	IP	X5D	X5D
Full appliance weight	kg	33,9	33,9

**Flow rate/head graph
VICTRIX 24 TT/20 X TT**

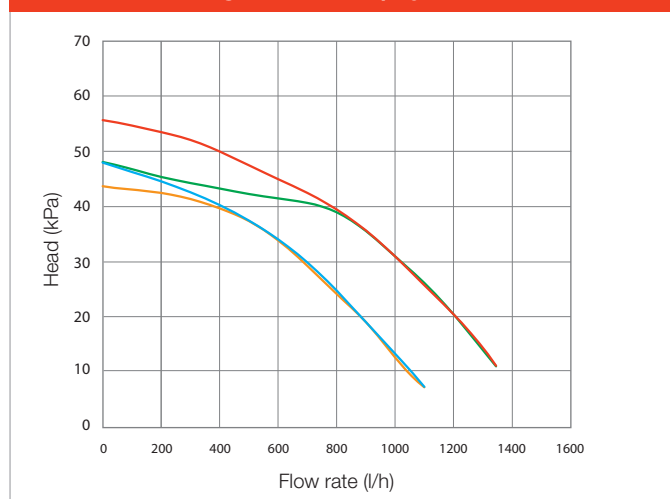

Available head for central heating:

- at top speed with excluded by-pass
- at top speed with inserted by-pass
- at 2 speed with excluded by-pass
- at 2 speed with inserted by-pass





OPTIONAL

Main Options	Code
CAR ^{v2} (modulating remote control)	3.021395
CAR ^{v2} WIRELESS (modulating remote control)	3.021623
MINI CRD (Mini Digital Remote Control)	3.020167
DIM ^{v2} Range Multisystem distribution manifolds	varius
External probe	3.014083
Relay board kit	3.015350
Connection kit for combi models NEW	3.019264
Connection kit for "X" models NEW	3.024907
Storage tank connection kit VICTRIX X TT NEW	3.024609
Safety thermostat kit	3.019229
Magnetic cyclone filter kit (important in case of boiler replacement in order to restrain possible ferrous)	3.024176
Solar probe kit, for combi models (only together with the connection kit code 3.019264)	3.021452
Anti-scale kit VICTRIX 24 TT	3.017323
Antifreeze protection kit -15 °C	3.017324
Cover kit (Useful on outdoor in partially protected area for configuration type B) NEW	3.024608

Dimensions and connections

VICTRIX 24 TT

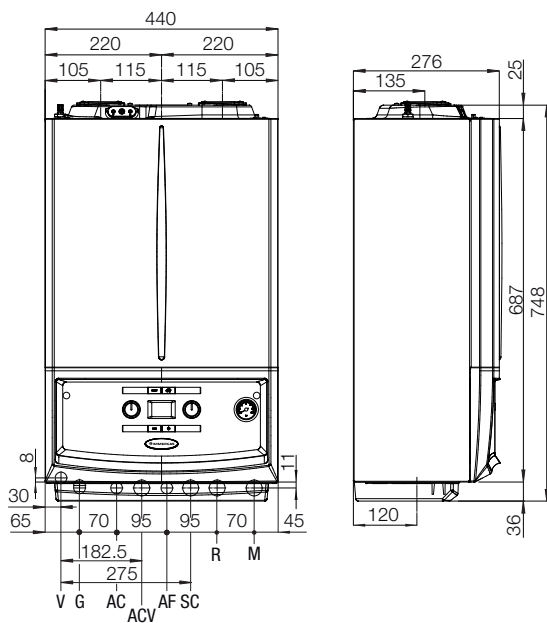

VICTRIX 20 X TT

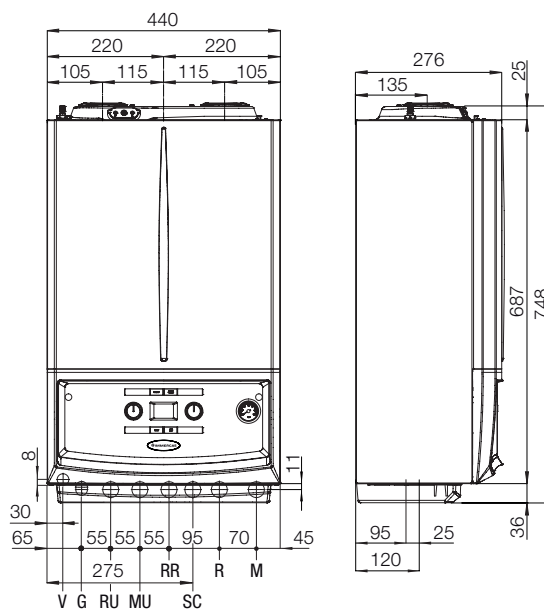

VICTRIX 24 TT hydraulic connections

Gas	D.H.W.		System	
	AC	AF	R	M
G	1/2"	1/2"	3/4"	3/4"

VICTRIX 20 X TT hydraulic connections

Gas	D.H.W.		System	
	RR	MU-RU*	R	M
3/4"	1/2"	3/4"	3/4"	3/4"

* Only in case of storage tank connection kit

Key

- V Electrical connection
- G Gas supply
- AC Domestic hot water outlet
- AF Domestic cold water inlet
- RU Storage tank return (optional)
- MU Storage tank delivery (optional)
- RR System filling
- SC Condensate drain (minimum internal diameter Ø 13 mm)
- ACV Solar valve domestic hot water inlet
- R System return
- M System delivery
- A Outlet/Inlet
- B Inlet

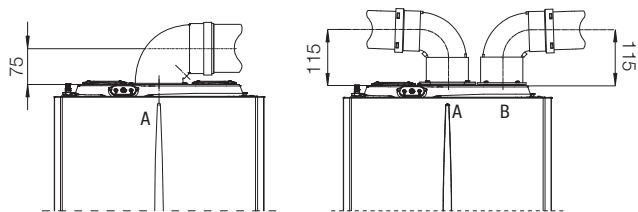

Horizontal kit Ø 60/100

Twin pipe kit Ø 80/80



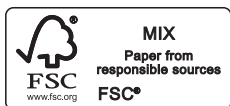

Follow us
Immergas Italia



immergas.com

Immergas S.p.A.
42041 Brescello (RE) - Italy
Tel. 0522.689011
Fax 0522.680617

	IMMERGAS IMMERGAS SPA - ITALY CERTIFIED COMPANY UNI EN ISO 9001:2008
Design, manufacture and post-sale assistance of gas boilers, gas water heaters and related accessories	