

MAXIMUM
USERS

Instruction and **IE**
warning book

 **IMMERGAS**

VICTRIX
12X TT 2 ERP
20X TT 2 ERP

1.038628ENG



STD.002571/004



Dear Customer,

Our compliments for having chosen a top-quality Immergas product, able to assure well-being and safety for a long period of time. As an Immergas customer you can also count on a qualified after-sales service, prepared and updated to guarantee constant efficiency of your boiler. Read the following pages carefully: you will be able to draw useful suggestions regarding the correct use of the appliance, the respect of which, will confirm your satisfaction for the Immergas product. For assistance and scheduled maintenance contact Authorised After-Sales centres: they have original spare parts and are specifically trained directly by the manufacturer.

General recommendations

All Immergas products are protected with suitable transport packaging.

The material must be stored in dry environments protected against bad weather.

The instruction book is an integral and essential part of the product and must be consigned to the new user also in the case of transfer or succession of ownership.

It must be stored with care and consulted carefully, as all of the warnings provide important safety indications for installation, use and maintenance stages.

This instructions manual provides technical information for installing Immergas boilers. As for the other issues related to boiler installation (e.g. safety in the work site, environment protection, injury prevention), it is necessary to comply with the provisions specified in the regulations in force and principles of good practice.

In compliance with legislation in force, the systems must be designed by qualified professionals, within the dimensional limits established by the Law. Installation and maintenance must be performed in compliance with the regulations in force, according to the manufacturer's instructions and by an authorised company, which has specific technical expertise in the system sector, as required by Law.

Improper installation or assembly of the Immergas appliance and/or components, accessories, kit and devices can cause unexpected problems to people, animals and objects. Read the instructions provided with the product carefully to ensure a proper installation.

Maintenance must be carried out by skilled technical staff. The Authorised After-sales Service represents a guarantee of qualifications and professionalism.

The appliance must only be destined for the use for which it has been expressly declared. Any other use will be considered improper and therefore potentially dangerous.

If errors occur during installation, operation and maintenance, due to non compliance with technical laws in force, standards or instructions contained in this book (or however supplied by the manufacturer), the manufacturer is excluded from any contractual and extra-contractual liability for any damages and the appliance warranty is invalidated.

The company **IMMERGAS S.p.A.**, with registered office in via Cisa Ligure 95 42041 Brescello (RE), declares that the design, manufacturing and after-sales assistance processes comply with the requirements of standard **UNI EN ISO 9001:2008**.

For further details on the product CE marking, request a copy of the Declaration of Conformity from the manufacturer, specifying the appliance model and the language of the country.

The manufacturer declines all liability due to printing or transcription errors, reserving the right to make any modifications to its technical and commercial documents without prior notice.

INDEX

INSTALLER	page
1 Boiler installation.....	5
1.1 Installation recommendations.....	5
1.2 Main dimensions.....	6
1.3 Antifreeze protection.....	6
1.4 Boiler connection unit.....	7
1.5 Gas connection.....	7
1.6 Hydraulic connection.....	7
1.7 Electric connection.....	8
1.8 Remote controls and room chrono- thermostats (Optional).....	8
1.9 External temperature probe (Optional).....	9
1.10 Immergas flue systems.....	10
1.11 Tables of resistance factors and equivalent lengths.....	10
1.12 Outdoor installation in a partially protected area.....	12
1.13 Concentric horizontal kit installation.....	13
1.14 Concentric Vertical kit installation.....	14
1.15 Separator kit installation.....	15
1.16 Adaptor C9 kit installation.....	16
1.17 Ducting of flues or technical slots.....	17
1.18 Configuration type B, open chamber and forced draught for indoors.....	17
1.19 Flue exhaust to flue/chimney.....	17
1.20 Flues, chimneys, chimney pots and terminals.....	17
1.21 Water treatment system filling.....	18
1.22 System filling.....	18
1.23 Condensate trap filling.....	18
1.24 Gas system start-up.....	18
1.25 Boiler start up (ignition).....	18
1.26 Circulation pump.....	19
1.27 Kits available on request.....	19
1.28 Boiler components.....	20

USER	page
2 Use and maintenance instructions.....	21
2.1 Cleaning and maintenance.....	21
2.2 General warnings.....	21
2.3 Control panel.....	21
2.4 Using the boiler.....	22
2.5 Troubleshooting.....	22
2.6 Information menu.....	25
2.7 Boiler shutdown.....	25
2.8 Restoring central heating system pressure.....	25
2.9 System draining.....	25
2.10 Anti-freeze protection.....	25
2.11 Case cleaning.....	25
2.12 Decommissioning.....	25

MAINTENANCE TECHNICIAN	page
3 Boiler commissioning (initial check).....	26
3.1 Boiler Hydraulic diagram.....	26
3.2 Wiring diagram.....	27
3.3 Removable memory.....	28
3.4 Troubleshooting.....	28
3.5 Converting the boiler to other types of gas...28	28
3.6 Checks following conversion to another type of gas.....	28
3.7 Calibration type involving the replacement of a component.....	29
3.8 Complete calibration function.....	29
3.9 Adjusting the air gas ratio.....	30
3.10 Fast calibration.....	30
3.11 Flue test.....	31
3.12 Programming the P.C.B.....	31
3.13 Solar panels coupling function.....	34
3.14 "Chimney Sweep" function.....	34
3.15 Pump anti-block function.....	34
3.16 Three-way anti-block function.....	34
3.17 Radiators antifreeze function.....	34
3.18 P.C.B. periodic self-check.....	34
3.19 Automatic vent function.....	34
3.20 Yearly appliance check and maintenance.....	35
3.21 Casing removal.....	36
3.22 Variable heat output.....	38
3.23 Combustion parameters.....	39
3.24 Technical data.....	40
3.25 Key for Data nameplate.....	41
3.26 Technical parameters for combination boilers (in compliance with Regulation 813/2013).....	42
3.27 Product fiche (in compliance with Regulation 811/2013).....	43
3.28 Parameters for filling in the package fiche.....	44

1 BOILER INSTALLATION

1.1 INSTALLATION RECOMMENDATIONS.

The Victrix 12X-20X TT 2 ErP boiler was designed for wall mounted installation only; for heating and production of domestic hot water for domestic use and similar purposes.

The place of installation of the appliance and relative Immergas accessories must have suitable features (technical and structural) such to allow (always in safety, efficiency and comfortable conditions):

- installation (according to the provisions of the technical legislation and technical regulations);
- maintenance operations (including scheduled, periodic, routine and special maintenance);
- removal (to outdoors in the place for loading and transporting the appliances and components) as well as their eventual replacement with appliances and/or equivalent components.

The wall surface must be smooth, without any protrusions or recesses enabling access to the rear part. They are not designed to be installed on plinths or floors (Fig. 1-1).

By varying the type of installation the classification of the boiler also varies, precisely:

- **Type B₂₃ or B₅₃** boiler if installed using the relevant terminal for air intake directly from the room in which the boiler has been installed.
- **Type C boiler** if installed using concentric pipes or other types of pipes envisioned for sealed chamber boilers for air intake and expulsion of flue gas.

Only professionally enabled companies are authorised to install Immergas gas appliances. Installation must be carried out according to regulation standards, current legislation and in compliance with local technical regulations and the required technical procedures.

Attention: the manufacturer declines all liability for damages caused by boilers removed from other systems or for any non-conformities of such equipment.

Before installing the appliance, ensure that it is delivered in perfect condition; if in doubt, contact the supplier immediately. Packing materials (staples, nails, plastic bags, polystyrene foam, etc.) constitute a hazard and must be kept out of the reach of children. If the appliance is installed inside or between cabinets, ensure sufficient space for normal servicing; therefore it is advisable to leave clearance of at least 3 cm between the boiler casing and the vertical sides of the cabinet. Leave adequate space above the boiler for possible water and flue removal connections. Keep all flammable objects away from the appliance (paper, rags, plastic, polystyrene, etc.).

Do not place household appliances underneath the boiler as they could be damaged if the safety valve intervenes, if the drain trap is blocked, or if there are leaks from the hydraulic connections; otherwise, the manufacturer cannot be held responsible for any damage caused to the household appliances.

For the aforementioned reasons, we recommend not placing furnishings, furniture, etc. under the boiler.

In the event of malfunctions, faults or incorrect operation, turn the appliance off immediately and contact an authorised company (e.g. the Authorised Technical Assistance centre, which has specifically trained staff and original spare parts). Do not attempt to modify or repair the appliance alone.

Failure to comply with the above implies personal responsibility and invalidates the warranty.

• Installation regulations:

- this boiler can be installed outdoors in a partially protected area. A partially protected area is one in which the appliance is not exposed to the direct action of the weather (rain, snow, hail, etc..).

NOTE: this type of installation is only possible when permitted by the laws in force in the appliance's country of destination.

- Installation of gas appliances, flue exhaust pipes and combustion air intake pipes is forbidden in places with a fire risk (for example: garages, closed parking stalls), and in potentially dangerous places.
- Installation is prohibited on the vertical projection of cooking hobs.
- Installation is forbidden in places/rooms that constitute public areas of apartment buildings, internal stairways or other escape routes (e.g. floor landings, entrance halls, etc.).
- Installation is also forbidden in places/rooms that constitute public areas of apartment buildings such as cellars, entrance halls, attics, lofts, etc., unless otherwise provided for by local regulations in force.

Attention: wall mounting of the boiler must guarantee stable and efficient support for the generator

The plugs (standard supply) are only to be used to fix the appliance to the wall; they only ensure adequate support if inserted correctly (according to technical standards) in walls made of solid or semi-hollow brick or block. In the case of walls made from hollow brick or block, partitions with limited static properties, or in any case walls other than those indicated, a static test must be carried out to ensure adequate support.

These boilers are used to heat water to below boiling temperature in atmospheric pressure.

They must be connected to a central heating system and hot water circuit suited to their performance and capacity.

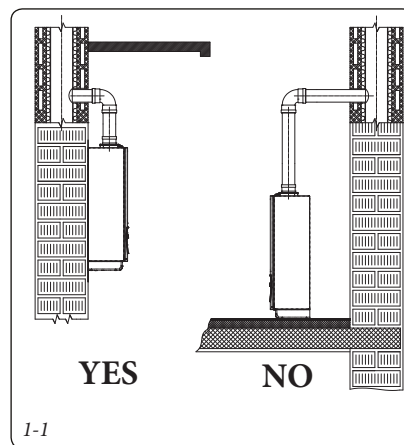

INSTALLER

USER

MAINTENANCE TECHNICIAN

1.2 MAIN DIMENSIONS.

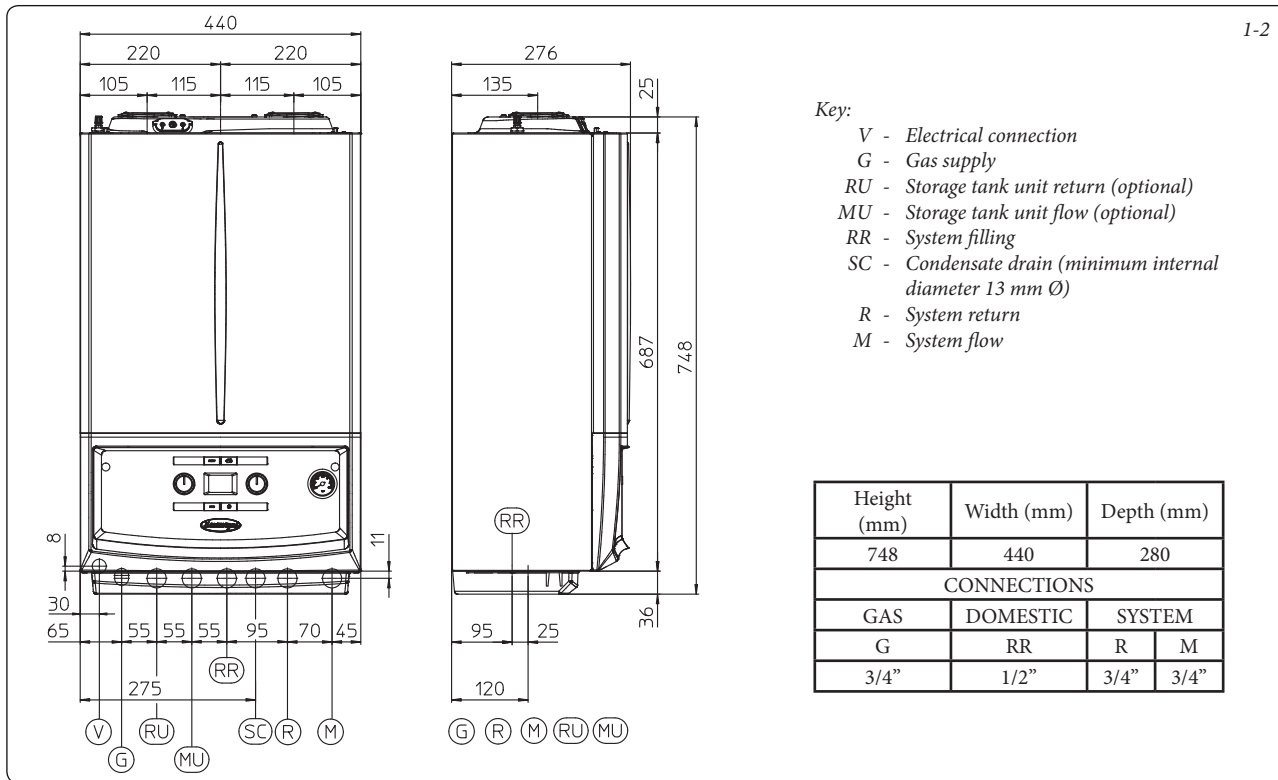

1.3 ANTIFREEZE PROTECTION.

Minimum temperature -5°C. The boiler comes standard with an anti-freeze function that activates the pump and burner when the system water temperature in the boiler falls below 4°C. *In these conditions the boiler is protected against freezing to an ambient temperature of -5°C.*

Minimum temperature -15°C. In the event the boiler is installed in a place where the temperature falls below -5°C, the appliance can freeze. *To prevent the risk of freezing follow the instructions below:*

- protect the central heating circuit from freezing by inserting a good-quality antifreeze liquid into this circuit, which is specially suited for central heating systems and which is manufacturer guaranteed not to cause damage to the heat exchanger or other components of the boiler. The antifreeze liquid must not be harmful to one's health. The instructions of the manufacturer of this liquid must be followed scrupulously regarding the percentage necessary with respect to the minimum temperature at which the system must be kept.

Attention: the excessive use of glycol could jeopardise the proper functioning of the appliance.

An aqueous solution must be made with potential pollution class of water 2 (EN 1717:2002 or local regulations in force).

The materials used for the central heating circuit of Immergas boilers withstand ethylene and propylene glycol based antifreeze liquids (if the mixtures are prepared perfectly).

For life and possible disposal, follow the supplier's instructions.

- Protect the domestic hot water circuit against freezing by using an accessory that is supplied on request (anti-freeze kit) comprising two electric heating elements, the relevant cables and a control thermostat (carefully read the installation instructions contained in the accessory kit pack).

In these conditions the boiler is protected against freezing to temperature of -15°C.

Boiler antifreeze protection (both -5°C and -15°C) is thus ensured only if:

- the boiler is correctly connected to gas and electricity power supply circuits;
- the boiler is powered constantly;
- the boiler is not in "off" mode;
- the boiler is not in anomaly conditions (par. 2.5);
- the essential components of the boiler and/or antifreeze kit are not faulty.

The warranty does not cover damage due to interruption of the electrical power supply and failure to comply with that stated on the previous page.

NOTE: if the boiler is installed in places where the temperature falls below 0°C the domestic hot water and central heating attachment pipes must be insulated.

1.4 BOILER CONNECTION UNIT.

The connection unit, which is composed of all the required accessories to connect the appliance's hydraulic and gas system, is furnished as an optional kit. Execute connections as indicated in the relative instructions sheet by using the connections represented in fig. 1-3.

1.5 GAS CONNECTION.

Our boilers are designed to operate with methane gas (G20) and LPG. Supply pipes must be the same as or larger than the 3/4" G boiler fitting. Before connecting the gas line, carefully clean inside all the fuel feed system pipes to remove any residue that could impair boiler efficiency. Also make sure the gas corresponds to that for which the boiler is prepared (see boiler data name plate). If different, the appliance must be converted for operation with the other type of gas (see converting appliance for other gas types). The dynamic gas supply (methane or LPG) pressure must also be checked according to the type used in the boiler, which must comply with the technical standards in force, as insufficient levels can reduce generator output and cause malfunctions. Ensure correct gas cock connection. The gas supply pipe must be suitably dimensioned according to current regulations in order to guarantee correct gas flow rate to the burner even in conditions of maximum generator output and to guarantee appliance efficiency (technical specifications). The coupling system must conform to technical standards in force.

Fuel gas quality. The appliance was designed to operate with combustible gas free of impurities; otherwise it is advisable to fit special filters upstream of the appliance to restore the purity of the fuel.

Storage tanks (in case of supply from LPG depot).

- New LPG storage tanks may contain residual inert gases (nitrogen) that degrade the mixture delivered to the appliance causing functioning anomalies.

- Due to the composition of the LPG mixture, layering of the mixture components may occur during the period of storage in the tanks. This can cause a variation in the heating power of the mixture delivered to the appliance, with subsequent change in its performance.

1.6 HYDRAULIC CONNECTION.

Attention: in order not to void the condensation module warranty, before making the boiler connections, carefully wash the heating system (pipes, radiators, etc.) with special pickling or descaling products to remove any deposits that could compromise correct boiler operation.

A treatment of the heating and water system water is required, in compliance with the technical standards in force, in order to protect the system and the appliance from deposits (e.g. scale), slurry or other hazardous deposits. In order not to void the heat exchanger warranty, you are required to comply with what has been prescribed in paragraph 1.21.

Water connections must be made in a rational way using the couplings on the boiler template.

Attention: the manufacturer declines all liability in the event of damage caused by the inclusion of automatic filling that is not its own brand.

In order to meet the system requirements established by the regulations in force in relation to the pollution of drinking water, we recommend installing the IMMERGAS anti-backflow kit to be used upstream of the cold water inlet connection of the boiler. It is also recommended that the heat transfer fluid (e.g. water + glycol) entered in the primary circuit of the boiler (heating circuit), complies with the local regulations in force.

Attention: to preserve the duration and the efficiency features of the appliance, in the presence of water whose features can lead to the deposit of scale, installation of the "polyphosphate dispenser" kit is recommended.

3-bar safety valve. Discharge of the safety valve has been conveyed to the condensate drain trap. Consequently, in the event of valve intervention, the discharged liquid will end up in the sewer system through the drainpipe of the condensate drain trap.

The appliance has anyhow been provided with a drain fitting (ref. 3 fig. 1-3) with a relative cap to check the presence of liquid in the drainage circuit and to check the 3-bar safety valve.

Condensate drain. To drain the condensate produced by the appliance, it is necessary to connect to the drainage system by means of acid condensate resistant pipes, with an internal Ø of at least 13 mm. The system connecting the appliance to the drainage system must be carried out in such a way as to prevent freezing of the liquid contained in it. Before appliance ignition, ensure that the condensate can be correctly removed. After first ignition, check that the drain trap is filled with condensate (para. 1.22). Also, comply with national and local regulations on discharging waste waters.

In the event condensate is not discharged into the wastewater drainage system, a condensate neutraliser must be installed to ensure compliance with the parameters established by the legislation in force.

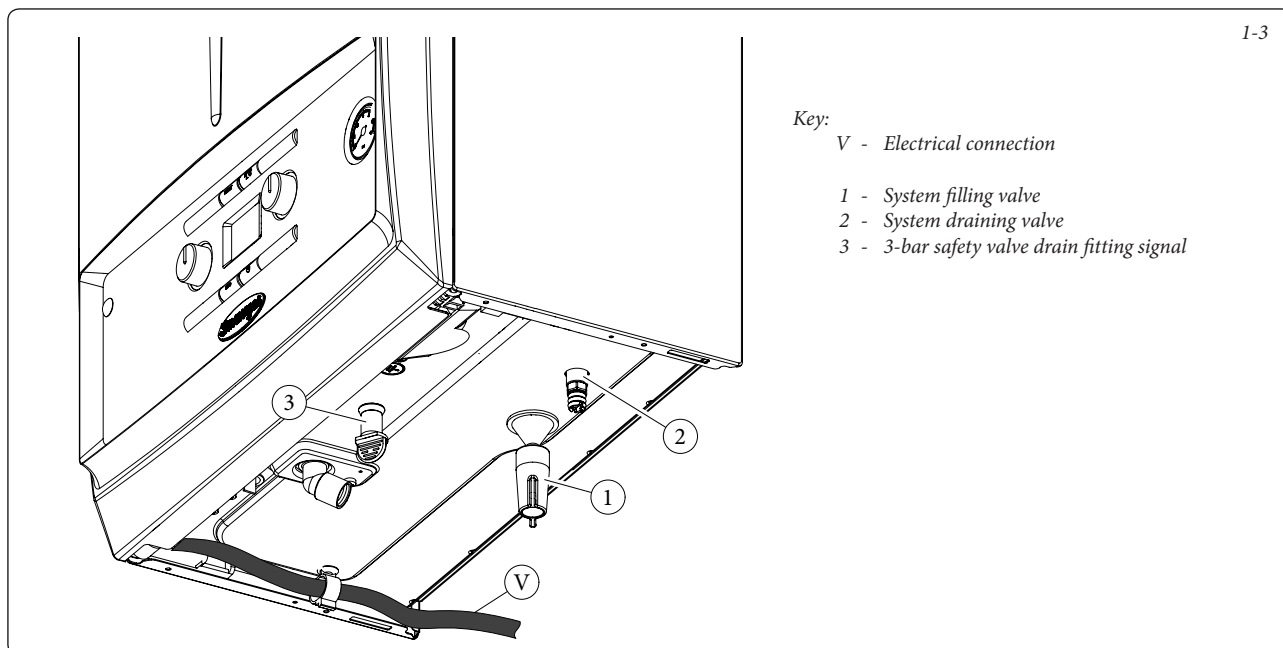

1.7 ELECTRIC CONNECTION.

The appliance has an IPX5D protection degree, electrical safety of the appliance is reached only when it is connected properly to an efficient earthing system as specified by current safety standards.

Attention: the manufacturer declines any responsibility for damage or physical injury caused by failure to connect the boiler to an efficient earth system or failure to comply with the reference standards.

- Open the control panel connections compartment (Fig. 1-4).

To carry out electrical connections, all you have to do is open the connections compartment as follows.

- Remove the front panel (Fig. 3-15b).
- Remove the cover (b fig. 1-4).
 - 1) Loosen the two screws (a).
 - 2) Press the two hooks on the cover (b).
 - 3) Remove the cover (b) from the control panel (c).
- At this point, it is possible to access the terminal board (d).

Also ensure that the electrical installation corresponds to maximum absorbed power specifications as shown on the boiler data nameplate. Boilers are supplied complete with an "X" type power cable without plug. The power supply cable must be connected to a 230V $\pm 10\%$ / 50Hz mains supply respecting L-N polarity and earth connection;  this network must also have a multi-pole circuit breaker with class III over-voltage category.

To protect from possible dispersions of DC voltage one must provide a type A differential safety device.

When replacing the power supply cable, contact a qualified company (e.g. the Authorised After-Sales Technical Assistance Service). The power cable must be laid as shown (Fig. 1-3).

In the event of mains fuse replacement on the P.C.B., use a 3.15A quick-blow fuse. For the main power supply to the appliance, never use adapters, multiple sockets or extension leads.

N.B.: connect terminals 36 and 37 to electrically connect the boiler to the storage tank unit, eliminating resistance R8 in the boiler (Fig. 3-2).

Installation with system operating at direct low temperature. The boiler can directly supply a low-temperature system by setting the flow temperature adjustment range "t0" and "t1" (Par. 3.11). In this situation it is good practice to insert a relevant safety kit (optional) made up from a thermostat (with adjustable temperature). Execute connection to terminal boards 14 and 15, eliminating jumper X70 (Fig. 3-2). The thermostat must be positioned on the system flow pipe at a distance of at least 2 metres from the boiler.

1.8 REMOTE CONTROLS AND ROOM CHRONO-THERMOSTATS (OPTIONAL).

The boiler is prepared for the application of room chrono-thermostats or remote controls, which are available as optional kits (Fig. 1-5). All Immergas chrono-thermostats are connected with 2 wires only. Carefully read the user and assembly instructions contained in the accessory kit.

- On/Off Immergas digital chrono-thermostat. The chrono-thermostat allows:
 - set two room temperature value: one for daytime (comfort temperature) and one for night-time (reduced temperature);
 - set a weekly program with four daily switch on and switch off times;
 - select the required operating mode from the various possible alternatives:
 - manual operation (with adjustable temperature).
 - automatic operation (with set programme).
 - forced automatic operation (momentarily changing the temperature of the automatic programme).

The chrono-thermostat is powered by two 1.5V LR 6 type alkaline batteries.

- Comando Amico Remoto Remote Control Device ^{V2} (CAR^{V2}) with climate chrono-thermostat function. In addition to the functions described in the previous point, the CAR^{V2} panel enables the user to control all the important information regarding operation of the appliance and the heating system with the opportunity to easily intervene on the previously set parameters, without having to go to where the appliance is installed. The panel is provided with self-diagnosis to display any boiler functioning anomalies. The climate chrono-thermostat incorporated into the remote panel enables

the system flow temperature to be adjusted to the actual needs of the room being heated, in order to obtain the desired room temperature with extreme precision and therefore with evident saving in running costs. The CAR^{V2} is fed directly by the boiler by means of the same 2 wires used for the transmission of data between the boiler and device.

Important: if the system is subdivided into zones using the relevant kit, the CAR^{V2} must be used with its climate thermostat function disabled, i.e. it must be set to On/Off mode.

Comando Amico Remoto Remote Control ^{V2} or On/Off chrono-thermostat electrical connections (Optional). *The operations described below must be performed after having removed the voltage from the appliance.* Any thermostat or On/Off environment chrono-thermostat must be connected to clamps 40 and 41 eliminating jumper X40 (Fig. 3-2). Make sure that the On/Off thermostat contact is of the "clean" type, i.e. independent of the mains voltage, otherwise the P.C.B. would be damaged. Any Comando Amico Remoto Remote Control ^{V2} must be connected to clamps 44 and 41 eliminating jumper X40 on the P.C.B., paying attention not to invert the polarity in the connections (Fig. 3-2).

Important: if the Comando Amico Remoto Remote Control ^{V2} or any other On/Off chrono-thermostat is used, arrange two separate lines in compliance with current regulations regarding electrical systems. No boiler pipes must ever be used to earth the electric system or telephone lines. Ensure elimination of this risk before making the boiler electrical connections.

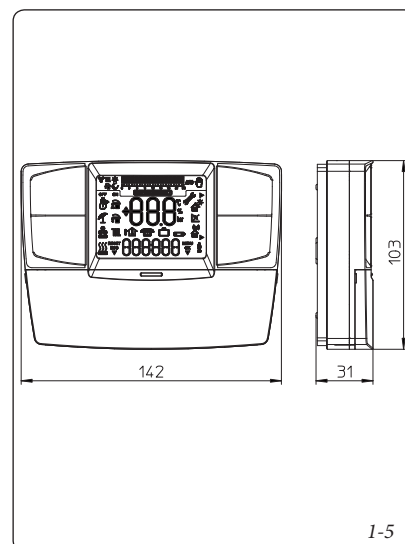
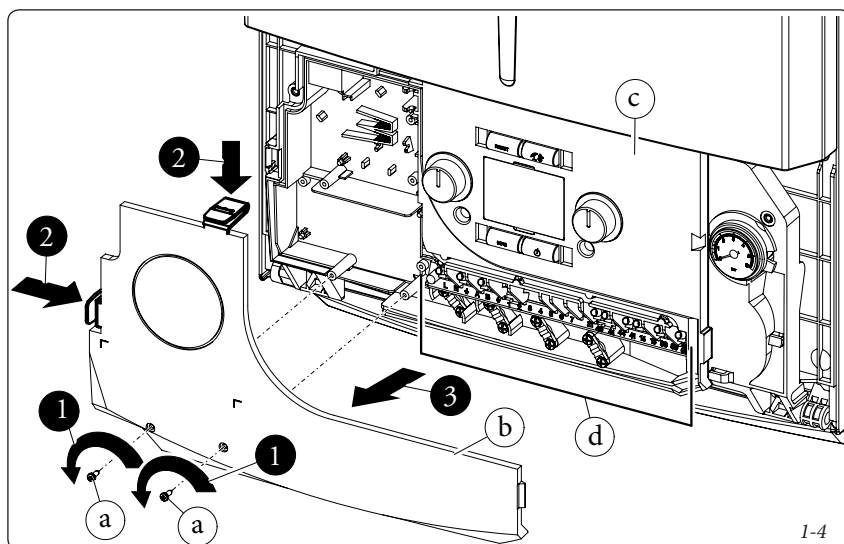

1.9 EXTERNAL TEMPERATURE PROBE (OPTIONAL).

The boiler is designed for the application of the external temperature probe (Fig. 1-6), which is available as an optional kit. Refer to the relative instruction sheet for positioning of the external probe.

The probe can be connected directly to the boiler electrical system and allows the max. system flow temperature to be automatically decreased when the external temperature increases, in order to adjust the heat supplied to the system according to the change in external temperature. The external probe always operates when connected, regardless of the presence or type of room chrono-thermostat used and can work in combination with Immergas chrono-thermostats. The correlation between system flow temperature and external temperature is determined by the position of the central heating selector switch on the boiler control panel (or on the CAR^{V2} control panel if connected to the boiler) according to the curves shown in the diagram (Fig. 1-7). The electric connection of the external probe must be made on clamps 38 and 39 on the terminal board in the boiler control panel (Fig. 3-2).

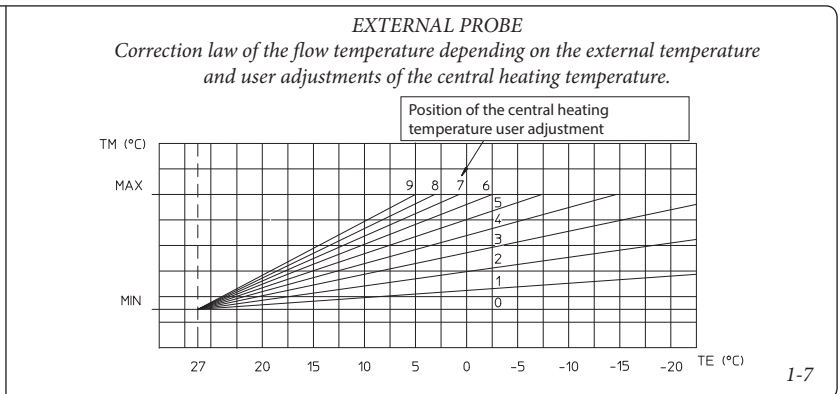
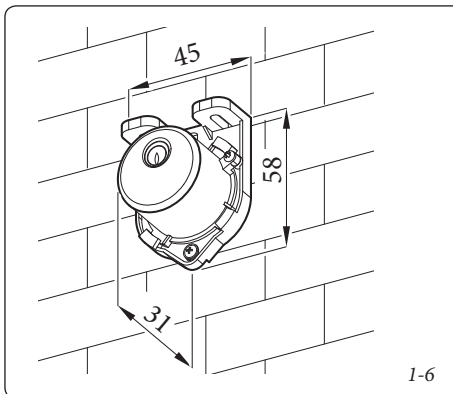

1.10 IMMERGAS FLUE SYSTEMS.

Immergas supplies various solutions separately from the boilers regarding the installation of air intake terminals and flue exhaust, which are fundamental for boiler operation.

Attention: the boiler must be installed exclusively with an original Immergas “Green Range” inspectionable air intake system and fumes extraction system made of plastic, with the exception of the C6 configuration, as required by the regulations in force.

The plastic pipes cannot be installed outdoors, for tracts longer than 40 cm, without suitable protection from UV rays and other atmospheric agents.

This system can be identified by an identification mark and special distinctive marking bearing the note: “only for condensing boilers”.

• Resistance factors and equivalent lengths. Each flue component has a *Resistance Factor* based on experimental tests and specified in the table below. The Resistance Factor for individual components is independent from the type of boiler on which it is installed and has a dimensionless size. It is however, conditioned by the temperature of the fluids that pass through the pipe and therefore, varies according to applications for air intake or flue exhaust. Each single component has a resistance corresponding to a certain length in metres of pipe of the same diameter; the so-called *equivalent length*, can be obtained from the ratio between the relative Resistance Factors. *All boilers have an experimentally obtainable maximum Resistance Factor equal to 100.* The maximum Resistance Factor allowed corresponds to the resistance encountered with the maximum allowed pipe length for each type of Terminal Kit. This information allows calculations to be made to verify the possibility of setting up various flue configurations.

- **Positioning the gaskets (black) for “green range” flue systems.** Position the gasket correctly (for bends and extensions) (Fig. 1-8):
 - gasket (A) with notches, to use for bends;
 - gasket (B) without notches, to use for extensions;

N.B.: if necessary, to ease the push-fitting, spread the elements with commonly-used talc.





- Coupling extension pipes and concentric elbows. To install push-fitting extensions with other elements of the flue, proceed as follows: Install the concentric pipe or elbow with the male side (smooth) on the female side (with lip seal) to the end stop on the previously installed element in order to ensure sealing efficiency of the coupling.

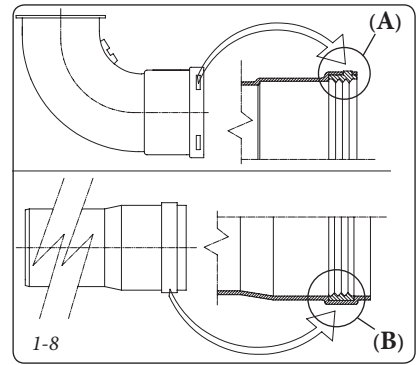





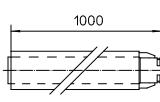
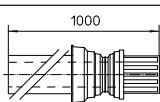





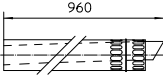

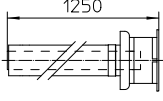
Attention: if the exhaust terminal and/or concentric extension pipe needs shortening, consider that the internal duct must always protrude by 5 mm with respect to the external duct.

- **N.B.:** for safety purposes, do not obstruct the boiler intake/exhaust terminal, even temporarily.
- **N.B.:** when installing horizontal pipes, a minimum inclination of 3% must be maintained and a section clip with pin must be installed every 3 metres.



1.11 TABLES OF RESISTANCE FACTORS AND EQUIVALENT LENGTHS.

TYPE OF DUCT	Resistance Factor (R)	Equivalent length in m of concentric pipe Ø 80/125
Concentric pipe Ø 80/125 m 1 	2.1	1
Concentric bend 90° Ø 80/125 	3.0	1.4
Concentric bend 45° Ø 80/125 	2.1	1
Terminal complete with concentric horizontal intake-exhaust Ø 80/125 	2.8	1.3
Terminal complete with concentric vertical intake-exhaust Ø 80/125 	3.6	1.7
Concentric bend 90° Ø 80/125 with inspection 	3.4	1.6
Stub pipe with inspection Ø 80/125 	3.4	1.6

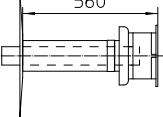
TYPE OF DUCT		Resistance Factor (R)	Equivalent length in m of concentric pipe Ø 60/100	Equivalent length in metres of pipe Ø 80	Equivalent length in metres of pipe Ø 60	Equivalent length in m of concentric pipe Ø 80/125
Concentric pipe Ø 60/100 m 1		Intake and Exhaust 6.4	m 1	Intake m 7.3	Exhaust m 1.9	m 3.0
				Exhaust m 5.3		
Concentric bend 90° Ø 60/100		Intake and Exhaust 8.2	m 1.3	Intake m 9.4	Exhaust m 2.5	m 3.9
				Exhaust m 6.8		
Concentric bend 45° Ø 60/100		Intake and Exhaust 6.4	m 1	Intake m 7.3	Exhaust m 1.9	m 3.0
				Exhaust m 5.3		
Terminal complete with concentric horizontal intake-exhaust Ø 60/100		Intake and Exhaust 15	m 2.3	Intake m 17.2	Exhaust m 4.5	m 7.1
				Exhaust m 12.5		
Concentric horizontal intake- exhaust terminal Ø 60/100		Intake and Exhaust 10	m 1.5	Intake m 11.5	Exhaust m 3.0	m 4.7
				Exhaust m 8.3		
Terminal complete with concentric vertical intake-exhaust Ø 60/100		Intake and Exhaust 16.3	m 2.5	Intake m 18.7	Exhaust m 4.9	m 7.7
				Exhaust m 13.6		
Concentric vertical intake-exhaust terminal Ø 60/100		Intake and Exhaust 9	m 1.4	Intake m 10.3	Exhaust m 2.7	m 4.3
				Exhaust m 7.5		
Pipe Ø 80 m 1		Intake 0.87 Exhaust 1.2	m 0.1	Intake m 1.0	Exhaust m 0.4	m 0.4
			m 0.2	Exhaust m 1.0		m 0.5
Complete intake terminal Ø 80 m 1		Intake 3	m 0.5	Intake m 3.4	Exhaust m 0.9	m 1.4
Intake terminal Ø 80 Exhaust terminal Ø 80		Intake 2.2 Exhaust 1.9	m 0.35	Intake m 2.5	Exhaust m 0.6	m 1
			m 0.3	Exhaust m 1.6		m 0.9
Bend 90° Ø 80		Intake 1.9 Exhaust 2.6	m 0.3	Intake m 2.2	Exhaust m 0.8	m 0.9
			m 0.4	Exhaust m 2.1		m 1.2
Bend 45° Ø 80		Intake 1.2 Exhaust 1.6	m 0.2	Intake m 1.4	Exhaust m 0.5	m 0.5
			m 0.25	Exhaust m 1.3		0.7
Pipe Ø 60 m 1 for ducting		Exhaust 3.3	m 0.5	Intake 3.8	Exhaust m 1.0	m 1.5
				Exhaust 2.7		
Bend 90° Ø 60 for ducting		Exhaust 3.5	m 0.55	Intake 4.0	Exhaust m 1.1	m 1.6
				Exhaust 2.9		
Reduction Ø 80/60		Intake and Exhaust 2.6	m 0.4	Intake m 3.0	Exhaust m 0.8	m 1.2
				Exhaust m 2.1		
Terminal complete with exhaust vertical Ø 60 for ducting		Exhaust 12.2	m 1.9	Intake m 14	Exhaust m 3.7	m 5.8
				Exhaust m 10.1		

1.12 OUTDOOR INSTALLATION IN A PARTIALLY PROTECTED AREA.

N.B.: a partially protected area is one in which the appliance is not exposed to the direct action of the weather (rain, snow, hail, etc.).

This type of installation is only possible when permitted by the laws in force in the appliance's country of destination.

• Configuration type B, open chamber and forced draught.

Using the special coverage kit one can achieve direct air intake (Fig. 1-9) and fumes exhaust in a single flue or directly outside. In this configuration it is possible to install the boiler in a partially protected place. In this configuration the boiler is classified as type B₂₃.

With this configuration:

- air intake takes place directly from the environment in which the appliance is installed (outside);
- the fumes exhaust must be connected to its own single flue (B₂₃) or ducted directly outside via a vertical terminal for direct exhaust (B₅₃) or via an Immergas ducting system (B₅₃).

The technical regulations in force must be respected.

- **Coverage kit assembly (Fig. 1-10).** Remove the two plugs and the gaskets present from the two lateral holes with respect to the central one. Now cover the right intake hole using the relevant plate, fixing it onto the left side using the 2 previously-removed screws. Install the Ø 80 outlet flange on the central hole of the boiler, taking care to insert the gasket supplied with the kit and tighten by means of the screws provided. Install the upper cover, fixing it using the 4 screws present in the kit, positioning the relevant gaskets. Engage the 90° Ø 80 bend with the male end (smooth) in the female end (with lip seal) of the Ø 80 flange unit until it stops. Introduce the gasket, making it run along the bend. Fix it using the sheet steel plate and tighten by means of the straps present in the kit, making sure to block the 4 gasket flaps. Fit the male end (smooth) of the exhaust terminal into the the female end of the bend 90° Ø 80,

making sure that the relevant wall sealing plate is already fitted; this will ensure hold and joining of the elements making up the kit.

Max. length of exhaust duct. The flue pipe (both vertical or horizontal) can be extended to a max. length of 30 linear metres.

- Coupling of extension pipes. To install push-fitting extensions with other elements of the flue, proceed as follows: Couple the pipe or elbow with the male side (smooth) in the female side (with lip seal) to the end stop on the previously installed element. This will ensure sealing efficiency of the coupling.

• Configuration without cover kit in a partially protected location (type C boiler)

By leaving the side plugs fitted it is possible to install the appliance externally without the cover kit. Installation takes place using the Ø60/100, Ø 80/125 and separator Ø 80/80 concentric intake/ exhaust kits. Refer to the paragraph relative to indoor installation. In this configuration the upper cover kit guarantees additional protection for the boiler. It is recommended but not compulsory.

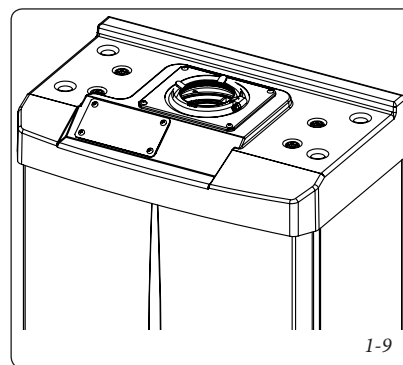

1-9

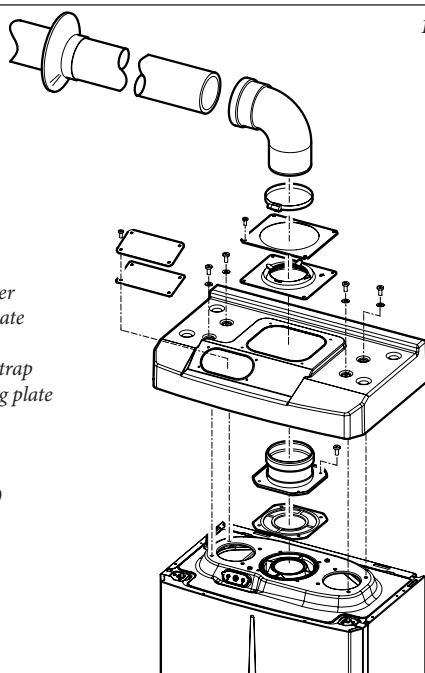

1-10

The cover kit includes:

- N° 1 Thermoformed cover
- N°1 Gasket clamping plate
- N°1 Gasket
- N°1 Gasket tightening strap
- N°1 Intake hole covering plate

The terminal kit includes:

- N° 1 Gasket
- N° 1 Discharge flange Ø 80
- N° 1 Bend 90° Ø 80
- N° 1 Drain pipe Ø 80
- N° 1 Wall sealing plate

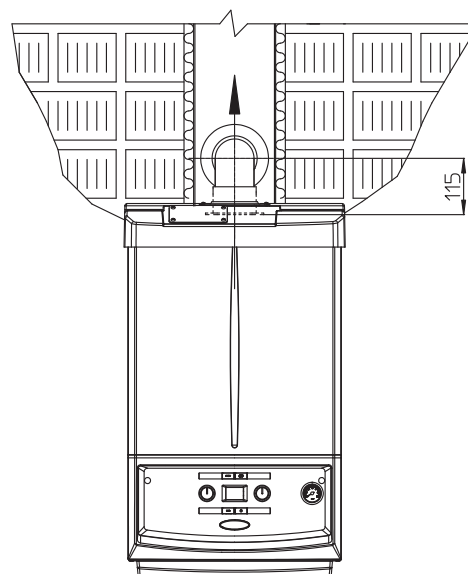

1-11

1.13 CONCENTRIC HORIZONTAL KIT INSTALLATION.

Type C configuration, sealed chamber and fan assisted.

Horizontal intake-exhaust kit Ø 60/100 Kit assembly (Fig. 1-12): install the bend with flange (2) on the central hole of the boiler, positioning gasket (1) with the circular projections downwards in contact with the boiler flange, and tighten using the screws present in the kit. Fit the Ø 60/100 (3) concentric terminal pipe with the male side (smooth) to the female side of the bend (2) up to the end stop; making sure that the internal and external wall sealing plate have been fitted, this will ensure sealing and joining of the elements making up the kit.

- Extensions for Ø 60/100 horizontal kit (Fig. 1-13). The kit with this configuration can be extended up to a *max. 12.9 horizontal m* including the terminal with grid and excluding the concentric bend leaving the boiler. This configuration corresponds to a resistance factor of 100. In this case the special extensions must be requested.

Immergas also provides a Ø 60/100 simplified terminal, which in combination with its extension kits allows you to reach a maximum extension of 11.9 metres.

- External grid. **N.B.:** for proper system operation the terminal with grid must be installed correctly ensuring that, the "high" indication on the terminal is observed during installation.

Horizontal intake-exhaust kit Ø 80/125 Kit assembly (Fig. 1-14): to install the kit Ø 80/125 one must use the flanged adapter kit in order to install the flue system Ø 80/125. Install the flanged adaptor (2) on the central hole of the boiler, positioning gasket (1) with the circular projections downwards in contact with the boiler flange, and tighten using the screws contained in the kit. Engage the bend (3) with the male side (smooth) to the end stop on the adapter (1). Fit the Ø 80/125 (5) concentric terminal pipe with the male side (smooth) to the female side of the bend (4) (with lip seals) up to the end top; making sure that the internal (6) and external wall sealing plate (7) have been fitted, this will ensure sealing and joining of the elements making up the kit.

- Extensions for horizontal kit Ø 80/125 (Fig. 1-15). The kit with this configuration can be extended up to a *max. length of 32 m*, including the terminal with grid and excluding the concentric bend leaving the boiler. If additional components are assembled, the length equivalent to the maximum allowed must be subtracted. In this case the special extensions must be requested.

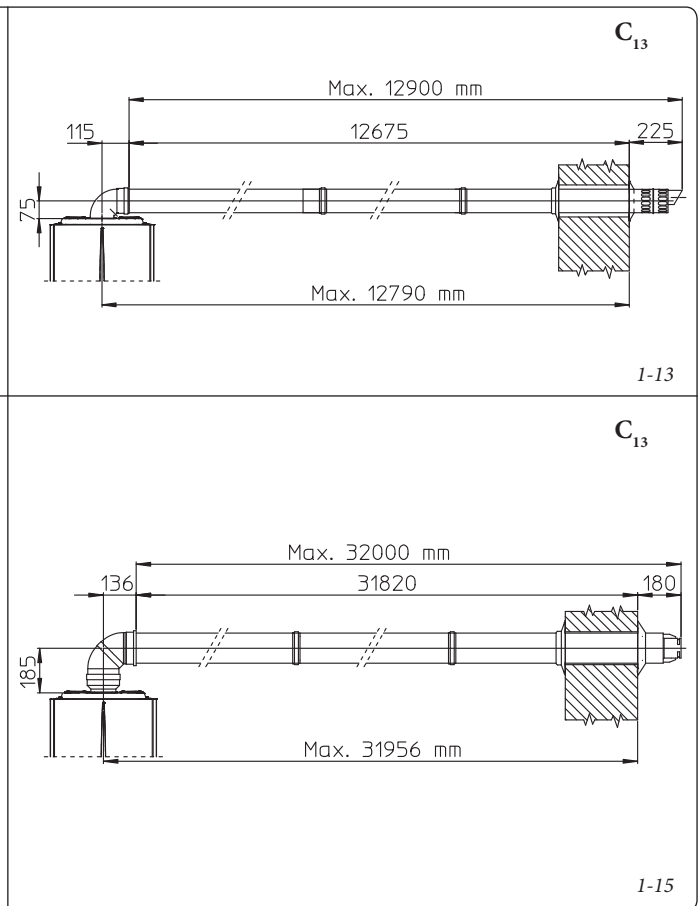
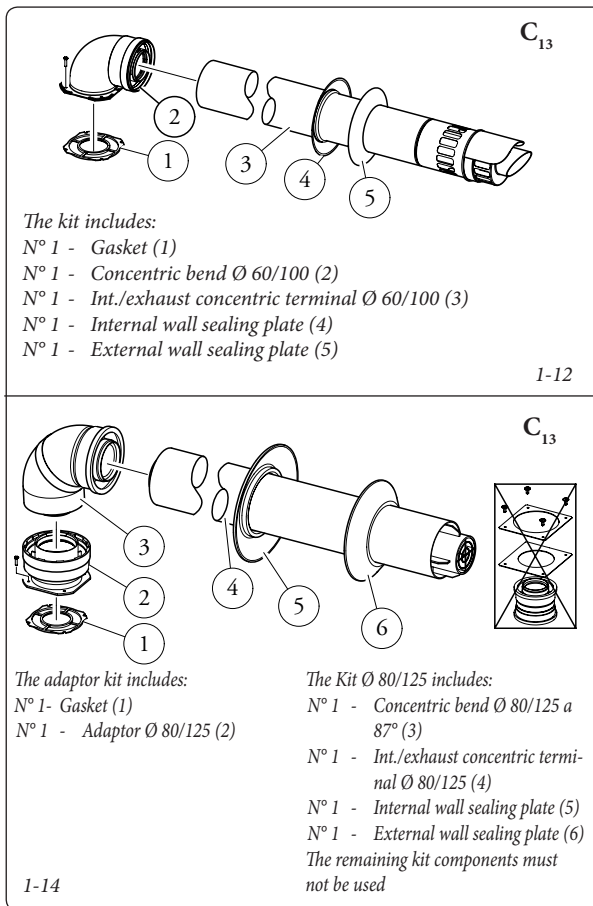

1.14 CONCENTRIC VERTICAL KIT INSTALLATION.

Type C configuration, sealed chamber and fan assisted.

Concentric vertical intake and exhaust kit. This vertical terminal is connected directly to the outside of the building for air intake and flue exhaust.

N.B.: the vertical kit with aluminium tile enables installation on terraces and roofs with a maximum slope of 45% (approx 25°) and the height between the terminal cap and half-shell (374 mm for Ø 60/100 and 260 mm for Ø 80/125) must always be observed.

Vertical kit with aluminium tile Ø 60/100.

Kit assembly (Fig. 1-16): install the concentric flange (2) on the central hole of the boiler, positioning gasket (1) with the circular projections downwards in contact with the boiler flange, and tighten using the screws contained in the kit. Installation of the fake aluminium tile: replace the tiles with the aluminium sheet (4), shaping it to ensure that rainwater runs off. Position the fixed half-shell (6) on the aluminium tile and insert the intake-exhaust pipe (5). Fit the Ø 60/100

(3) concentric terminal pipe with the male end (5) (smooth) into the flange (2) up to the stop; making sure that the wall sealing plate has been fitted (3), this will ensure sealing and joining of the elements making up the kit.

NOTE: when the boiler is installed in areas where very cold temperatures can be reached, a special anti-freeze kit is available that can be installed as an alternative to the standard kit.

- Extensions for vertical kit Ø 60/100 (Fig. 1-17). The kit with this configuration can be extended to a max. straight vertical length of 14.4 m, including the terminal. This configuration corresponds to a resistance factor of 100. In this case specific extensions must be requested.

Vertical kit with aluminium tile Ø 80/125.

Kit assembly (Fig. 1-18): to install the kit Ø 80/125 one must use the flanged adaptor kit in order to install the flue system Ø 80/125. Install the flanged adaptor (2) on the central hole of the boiler, positioning gasket (1) with the circular projections downwards in contact with the boiler flange and tighten using the screws contained

in the kit. Installation of the fake aluminium tile: replace the tiles with the aluminium sheet (4), shaping it to ensure that rainwater runs off. Position the fixed half-shell (5) on the aluminium tile and insert the intake-exhaust pipe (7). Fit the Ø 80/125 concentric terminal pipe with the male side (smooth) to the female side of the adapter (1) (with lip gaskets) up to the end stop; making sure that the wall sealing plate (3) has been fitted, this will ensure sealing and joining of the elements making up the kit.

- Extensions for vertical kit Ø 80/125 (Fig. 1-19). The kit with this configuration can be extended up to a max. length of 32 m including the terminal. If additional components are assembled, the length equivalent to the maximum allowed must be subtracted. In this case specific extensions must be requested.

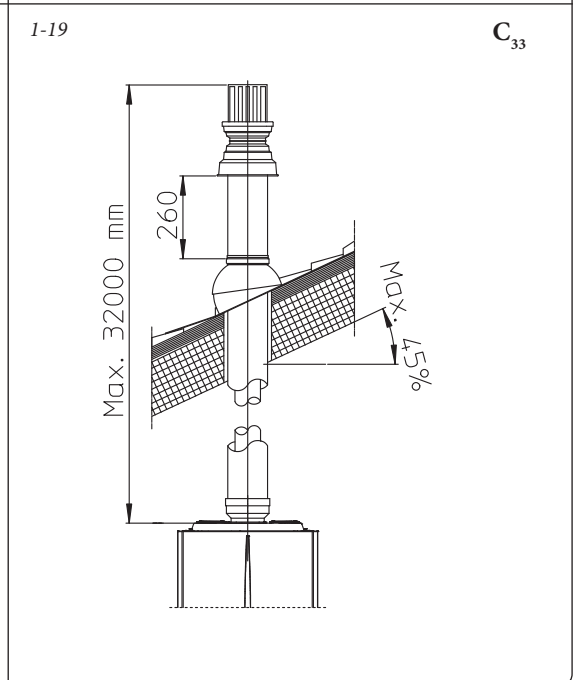
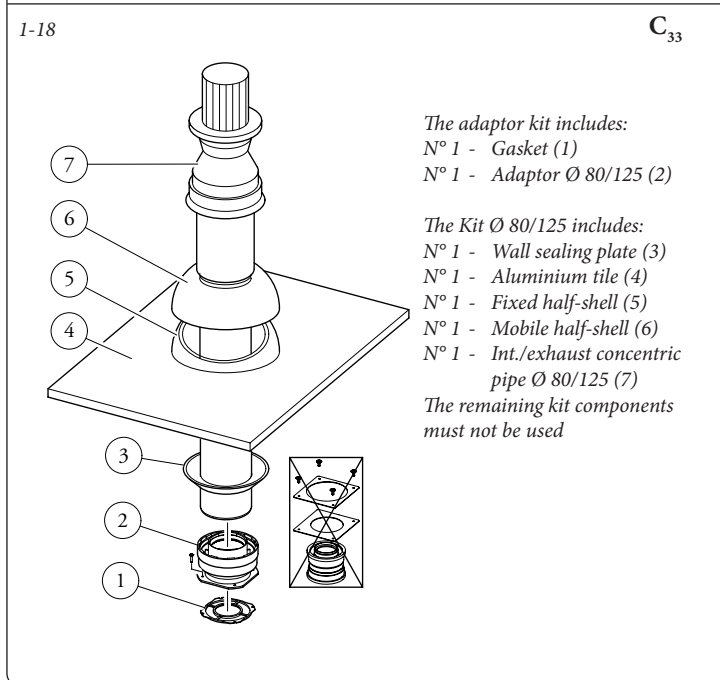
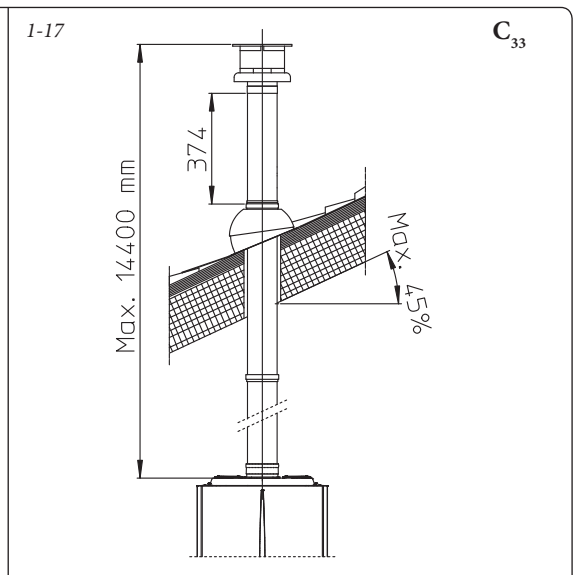
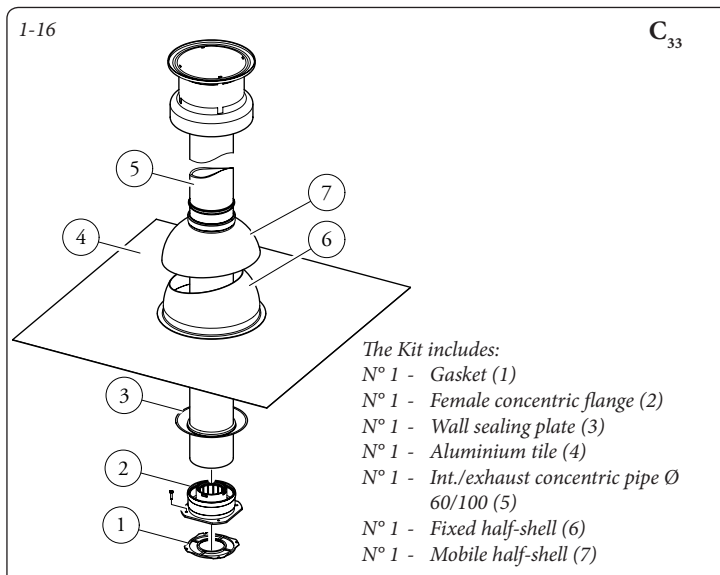

1.15 SEPARATOR KIT INSTALLATION.
Type C configuration, sealed chamber and fan assisted.

Separator kit Ø 80/80. This kit allows air to come in from outside the building and the exhaust to exit from the chimney, flue or intubated duct through divided flue exhaust and air intake pipes. Combustion products are expelled from pipe (S) (in plastic, so as to resist acid condensate). Air is taken in through duct (A) for combustion (this is also in plastic). The intake pipe (A) can be installed either on the right or left hand side of the central exhaust pipe (S). Both ducts can be routed in any direction.

- Kit assembly (Fig. 1-20): install flange (4) on the central hole of the boiler, positioning gasket (1) with the circular projections downwards in contact with the boiler flange, and tighten using the hex screws with flat tip contained in the kit. Remove the flat flange present in the lateral hole with respect to the central one (according to needs) and replace it with the flange (3), positioning the gasket (2) already present in the boiler and tighten using the supplied self-threading screws. Fit the male end (smooth) to the bends (5) in the female end of the flanges (3 and 4). Fit the intake terminal (6) with the male side (smooth) in the female side of the bend (5) up to the end stop, ensuring that the internal and external wall sealing plates are fitted. Fit the exhaust pipe (9) with the male side (smooth) to the female side of the bend (5) up to the end stop; making sure that the

internal wall sealing plate has been fitted, this will ensure sealing and joining of the elements making up the kit.

- Installation clearances (Fig. 1-21). The minimum installation clearance measurements of the Ø 80/80 separator terminal kit have been stated in some limit conditions.
- Extensions for separator kit Ø 80/80. The maximum vertical straight length (without bends) that can be used for Ø 80 intake and exhaust pipes is 41 metres, regardless from whether they are used for intake or exhaust. The maximum horizontal straight length (with bend in suction and in exhaust) that can be used for Ø 80 intake and exhaust pipes is 36 metres, regardless from whether they are used for intake or exhaust.

N.B.: to favour the removal of possible condensate forming in the exhaust pipe, tilt the pipes towards the boiler with a minimum slope of 1.5% (Fig. 1-22).

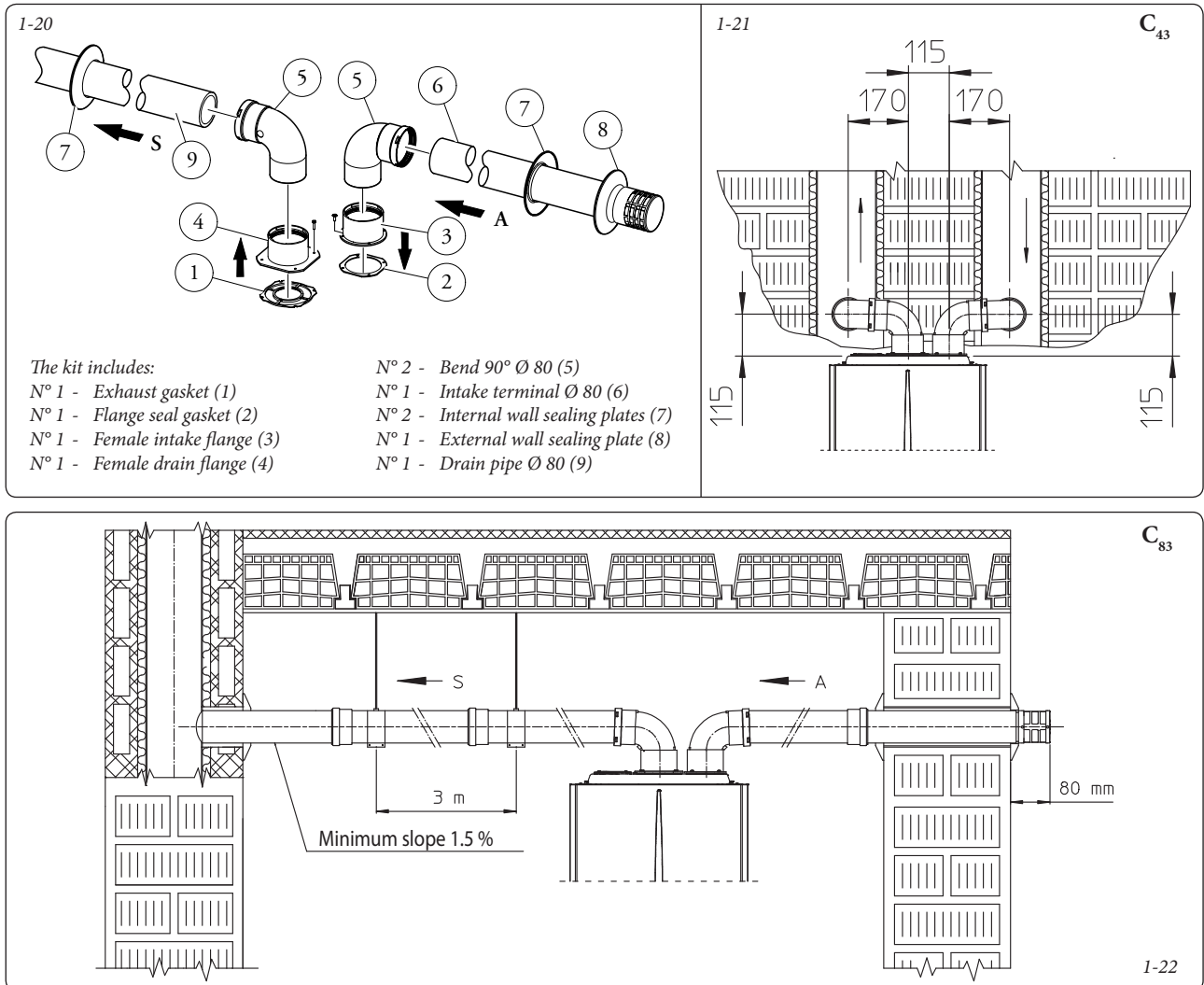

1.16 ADAPTOR C9 KIT INSTALLATION.

This kit allows to install an Immergas boiler in configuration "C₉₃", achieving the combustion air intake directly from the shaft featuring the fumes exhaust, obtained by means of a ducting system.

System composition.

The system must be combined with the following components (sold separately) to be functional and complete:

- kit C₉₃ version Ø 100 or Ø125
- ducting kit Ø 60 or Ø 80
- fumes exhaust kit Ø 60/100 or Ø 80/125 configured according to the installation and type of boiler.

Kit Assembly.

- Mount the components of kit "C9" on the door (A) of the ducting system (Fig. 1-24).
 - (Version Ø 125 only) mount the flanged adaptor (11) interposing the concentric gasket (10) on the boiler, fitting it with the screws (12).
 - Mount the ducting system as described in the relative instructions sheet.
 - Calculate the distances between the boiler drain and the bend of the ducting system.
 - Prepare the boiler flue system, making sure that the internal pipe of the concentric kit is fitted properly in the bend of the ducting system (quota "X" fig. 1-25), while the external pipe must be fitted on the adaptor until it stops (1).
- N.B.:** to encourage the removal of possible condensate forming in the exhaust pipe, tilt the pipes towards the boiler with a minimum slope of 1.5%.

- Mount the cover (A) complete with adaptor (1) and caps (6) on the wall and assemble the flue system to the ducting system.

N.B.: (version Ø 125 only) before assembly check the gaskets are in the right position. In the event component lubrication (already carried out by the manufacturer) is not sufficient, remove the residual lubricant using a dry cloth, then to ease fitting coat the parts with common or industrial talc.

Once all components have been assembled properly, the exhaust fumes will be expelled via the ducting system; the combustion air for normal boiler operation will be aspirated directly by the shaft (Fig. 1-25).

Technical data.

- The dimensions of the shafts must ensure a minimum gap between the outer wall of the smoke duct and the inner wall of the shaft: 30 mm for circular section shafts and 20 mm in the event of a square section shaft (Fig. 1-23).
- Maximum 2 changes of direction are allowed on the vertical section of the flue system with a maximum clearance angle of 30° with respect to the vertical.
- The maximum vertical extension using a Ø 60 ducting system is 13 m, the maximum extension includes 1 bend Ø 60/10 at 90°, 1 m of horizontal pipe 60/100, 1 90° ducted bend Ø 60 and the roof terminal for ducting.

To determine the C₉₃ flue system in configurations other than that described (Fig. 1-25) one must consider that 1 metre of ducted pipe according to the indications described has a resistance factor equal to 4.9.

- The maximum vertical extension using a Ø 80 ducting system is 28 m, the maximum extension includes 1 adapter 60/100 to 80/125, 1 87° bend Ø 80/125, 1 m of horizontal pipe 80/125, 1 90° ducted bend Ø 80 and the roof terminal for ducting.

To determine the C₉₃ flue system in configurations other than that described (Fig. 1-25) one must consider the following pressure drops:

- 1 m of concentric pipe Ø 80/125 = 1 m of ducted pipe;
- 1 87° bend = 1.4 m of ducted pipe;

Consequently one must subtract the equivalent length of the part added to the 28 m available.

1-23

Rigid Ø 60 ducting (A) mm	SHAFT (B) mm	SHAFT (C) mm
66	106	126

Rigid Ø 80 ducting (A) mm	SHAFT (B) mm	SHAFT (C) mm
86	126	146

Flexible Ø 80 ducting (A) mm	SHAFT (B) mm	SHAFT (C) mm
90	130	150

Kit composition:

Ref.	Qty	Description
1	1	Door adaptor Ø 100 or Ø 125
2	1	Door gasket made of neoprene
3	4	Screws 4.2 x 9 AF
4	1	Hex headed screw M6 x 20
5	1	Flat nylon washer M6
6	2	Door hole closure metal-sheet plate plug
7	1	Plug gasket made of neoprene
8	1	Toothed washer M6
9	1	Nut M6
10	1 (kit 80/125)	Concentric gasket Ø 60-100
11	1 (kit 80/125)	Flanged adaptor Ø 80-125)
12	4 (kit 80/125)	Hex headed screws M4 x 16 slotted
-	1 (kit 80/125)	Bag of lubricating talc

Installation drawings key:

- ① Unique identification of the component in the kit
- A Identification of the component not supplied in this kit

1-24

Supplied separately:

Ref.	Qty	Description
A	1	Ducting kit door

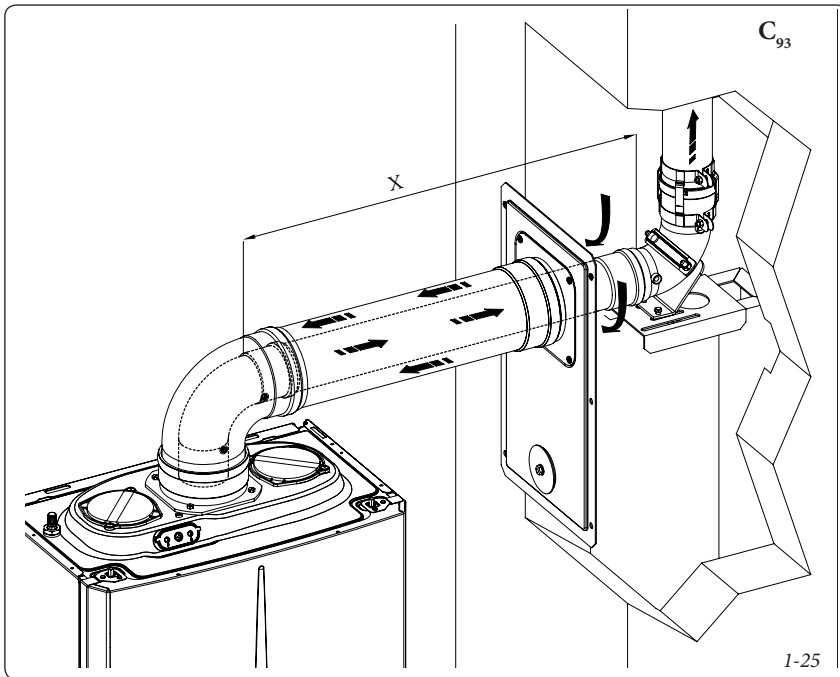

1.17 DUCTING OF FLUES OR TECHNICAL SLOTS.

Ducting is an operation through which, via the introduction of one or more relevant pipes, one achieves a system for the evacuation of the combustion products of a gas appliance, made up from the coupling of an existing or new ducting pipe with a chimney, flue or technical slot (also in new buildings) (Fig. 1-26). Ducting requires ducts declared to be suitable for the purpose by the manufacturer, following the installation and user instructions provided by the manufacturer and the requirements of the local standards in force.

Immergas ducting system. The Ø 60 rigid and Ø 80 flexible "Green Range" ducting systems must only be used for domestic use and with Immergas condensing boilers.

In any case, ducting operations must respect the provisions contained in the standard and in current technical regulations; in particular, the declaration of conformity must be compiled at the end of work and on commissioning of the ducted system. The instructions in the project or technical report must likewise be followed, in cases provided for by the standard and current technical regulations. The system or components of the system have a technical life complying with current standards, provided that:

- it is used in average atmospheric and environmental conditions, according to current regulations (absence of fumes, dusts or gases that can alter the normal thermophysical or chemical conditions; existence of temperatures coming within the standard range of daily variation, etc.).
- Installation and maintenance must be performed according to the indications supplied by the manufacturer and in compliance with the regulations in force.
- The maximum length specified by the manufacturer must be respected; in this regard:
 - The max. possible length of the Ø 60 flexible ducting vertical section is equal to 22 m. This length is obtained considering the complete Ø 80 exhaust terminal, 1m of Ø 80 pipe in exhaust, two 90° Ø 80 bends at boiler outlet.

- The max. possible length of the Ø 80 flexible ducting vertical section is equal to 30 m. This length is obtained considering the complete exhaust terminal, 1m of Ø 80 pipe in exhaust, two 90° Ø 80 bends at boiler outlet for connecting to the ducting system and two direction changes of the flexible hose inside the chimney/technical slot.
- The maximum possible length of the Ø 80 rigid ducting vertical section is equal to 30 m. This length is obtained considering the complete Ø 80 exhaust terminal, 1m of Ø 80 pipe in exhaust, two 90° Ø 80 bends on the boiler outlet.

1.18 CONFIGURATION TYPE B, OPEN CHAMBER AND FORCED DRAUGHT FOR INDOORS.

The appliance can be installed inside buildings in B_{23} or B_{53} mode; in this case, all technical rules and national and local regulations in force, must be complied with.

- type B open chamber boilers must not be installed in places where commercial, artisan or industrial activities take place, which use products that may develop volatile vapours or substances (e.g. acid vapours, glues, paints, solvents, combustibles, etc.), as well as dusts (e.g. dust deriving from the working of wood, coal fines, cement, etc.), which may be harmful for the components of the appliance and jeopardise operation.
- in B_{23} and B_{53} configuration the boilers must not be installed in bedrooms, bathrooms or bedsits, unless otherwise provided for by local regulations in force. They must neither be installed in rooms containing solid fuel heat generators nor in rooms communicating with said rooms.
- The installation of appliances in B_{23} and B_{53} configurations are only recommended in places that are not lived in and which are permanently ventilated.

To install them, one must use the coverage kit whose installation is referred to in paragraph 1.12.

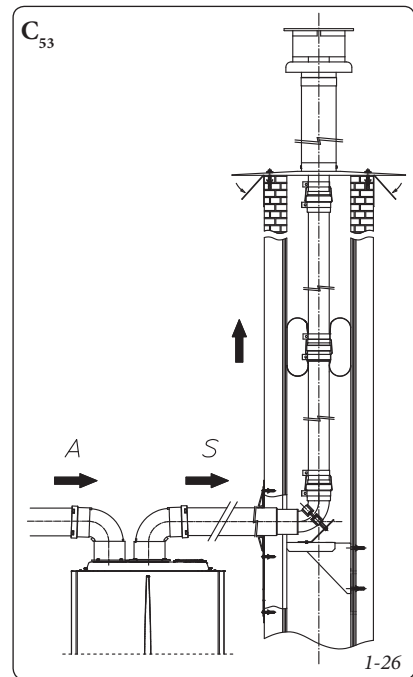

1.19 FLUE EXHAUST TO FLUE/CHIMNEY.

Flue exhaust does not necessarily have to be connected to a branched boiler traditional flue. The flue exhaust, for boiler clots installed in C configuration, can be connected to a special LAS type multiple flue. For B configurations, exhaust is only allowed into individual chimney or directly into the external atmosphere via a suitable terminal, unless otherwise provided for by local regulations in force. The multiple flues and the combined flues must also only be connected to type C appliances of the same type (condensing), having nominal heat inputs that do not differ by more than 30% less with respect to the maximum that can be attached and powered by the same fuel. The thermo-fluid dynamic features (flue flow rate, % of carbon dioxide, % humidity etc...) of the appliances attached to the same multiple flues or combined flues, must not differ by more than 10% with respect to the average boiler attached. Multiple and combined flues must be specially designed according to the calculation method and requirements of the technical standards in force, by a professionally qualified company. Chimney or flue sections for connection of the flue exhaust pipe must comply with requisites of technical standards in force.

1.20 FLUES, CHIMNEYS, CHIMNEY POTS AND TERMINALS.

The flues, chimneys and chimney pots for the evacuation of combustion products must be in compliance with applicable standards. Chimneys and roof-installed exhaust terminals must comply with the outlet height and with the distance from technical volumes set forth by the technical standards in force.

Positioning the wall flue exhaust terminals. The wall flue exhaust terminals must:

- be installed on external perimeter walls of the building;
- be positioned according to the minimum distances specified in current technical standards.

Combustion products exhaust of natural draught or fan assisted appliances in open-top closed environments. In spaces closed on all sides with open tops (ventilation pits, court-

yards etc.), direct combustion product exhaust is allowed for natural draught or fan assisted gas appliances with a heat input range from 4 to 35 kW, provided the conditions as per the current technical standards are respected.

1.21 WATER TREATMENT SYSTEM FILLING.

As already mentioned in the previous paragraphs, a treatment of the thermal and domestic system water is required, in compliance with the local standards in force.

The parameters that influence the duration and proper operation of the heat exchanger are the water's PH, hardness, conductivity, and oxygen, together with the system's processing residues (any welding residues), any oil present and corrosion products that can, in turn, cause damage to the heat exchanger.

In order to prevent this from happening, you are recommended to:

- Before installation on new systems as well as old ones, clean the system with clean water to eliminate solid residues contained therein.
- Clean the system with a chemical treatment:
 - Clean the new system with a suitable cleaning device (for example Sentinel X300, Fernox Cleaner F3 or Jenaqua 300) combined with thorough washing.
 - Clean the old system with a suitable cleaning device (for example Sentinel X400 or X800, Fernox Cleaner F3 or Jenaqua 400) combined with thorough washing.
- Check the maximum hardness and quantity of filling water referring to the graphics (Fig. 1-27). If the contents and hardness of the water are below the indicated curve, no specific treatment is required; otherwise, to limit the content of calcium carbonate, you must provide for water-filling treatment.
- For filling, you are not allowed to use water softened with the use of ionic-exchange resins or distilled water.
- Should you be required to provide for water treatment, this should be carried out by completely desalinating the filling water. As opposed to the complete softening process, desalinating the water completely not only removes hardening agents (Ca, Mg), but also eliminates all other minerals to reduce water-filling conductivity up to 10 microsiemens/cm. Given its low conductivity, desalinated water does not only prevent the formation of lime scale, but also serves as protection against corrosion.
- Insert a suitable inhibitor / passivator (for example Sentinel X100, Fernot Protector F1, or Jenaqua 100); if required, also insert appropriate antifreeze (such as for example Sentinel X500, Fernox Alphi 11 or Jenaqua 500).
- Check electrical conduction of the water, which should not be lower than 2000 $\mu\text{s}/\text{cm}$ in the case of treated water and lower than 600 $\mu\text{s}/\text{cm}$ in the case of non-treated water.
- To prevent corrosion, the water system's PH should be between 6.5 and 8.5.
- Check the maximum content of chlorides, which should be less than 250 mg/l.

N.B.: for quantities and methods of use of water-treatment products, refer to the instructions provided by their manufacturer.

1.22 SYSTEM FILLING.

Once the boiler is connected, proceed with system filling via the filling cock (Fig. 1-29 and 1-3). Filling is performed at low speed to ensure release of air bubbles in the water via the boiler and heating system vents.

The boiler has a built-in automatic venting valve on the circulator. *Check if the cap is loose.* Open the radiator vent valves.

Close radiator vent valves when only water escapes from them.

Close the filling cock when the boiler pressure gauge indicates approx. 1.2 bar.

N.B.: during these operations, enable the automatic vent functions on the boiler (active on first ignition).

1.23 CONDENSATE TRAP FILLING.

On first lighting of the boiler, flue gas may come out the condensate drain; after a few minutes' operation check that this no longer occurs. This means that the drain trap is filled with condensate to the correct level preventing the passage of flue gas.

1.24 GAS SYSTEM START-UP.

To start up the system, refer to the technical standard in force.

In particular, for new gas systems:

- open windows and doors;
- avoid presence of sparks or open flames;
- bleed all air from the pipelines;
- check that the internal system is properly sealed according to the specifications set forth by technical regulations in force.

1.25 BOILER START UP (IGNITION).

To commission the boiler (the operations listed below must only be performed by a qualified firm and without any unauthorised persons):

- check that the internal system is properly sealed according to the specifications set forth by technical regulations in force;
- ensure that the type of gas used corresponds to the boiler settings (the type of gas appears on the display on first electrical supply voltage, or by checking the relative parameter "G");
- check connection to a 230V-50Hz power mains, correct L-N polarity and earthing connection;
- Check that there are external factors that may cause the formation of fuel pockets;
- switch the boiler on and check correct ignition;
- make sure that the gas flow rate and relevant pressure values comply with those given in the manual (Par. 3.22);
- ensure that the safety device intervenes in the event of gas supply failure and check the relative intervention time;
- check the intervention of the main switch located upstream from the boiler and in the boiler;
- check that the intake and/or exhaust terminals (if fitted) are not blocked.
- Carry out the flue test and set the relative parameter "F0".

The boiler must not be started up even if only one of the checks should be negative.

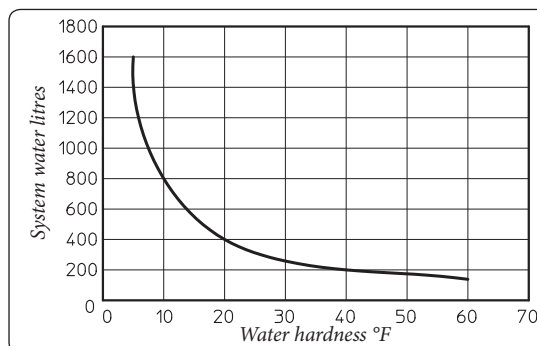

N.B.: the graph refers to the entire life cycle of the system. Therefore, also consider scheduled and unscheduled maintenance, which involves emptying and filling the said system.

1-27

1.26 CIRCULATION PUMP.

The boilers are supplied with a variable speed circulator pump.

In the central heating mode, the following operating modes are available and can be selected from the "P.C.B. programming" menu.

NOTE.: the ΔT can be controlled compatibly with the characteristics of the central heating system and of the boiler.

- **Proportional head (ΔT = 0):** the circulator speed varies according to the power emitted by the burner, the greater the power the greater the speed.
- **ΔT Constant (ΔT = 5 ÷ 25 K):** the pump speed varies to maintain the ΔT constant between the system flow and return according to set value K (ΔT = 15 Default).
- **Fixed (5 ÷ 9):** by setting parameters "A3" and "A4" at the same value, the pump operates at constant speed.

N.B.: for the boiler to work properly, it is not allowed to drop below the minimum value indicated above.

In domestic hot water mode the circulator pump always runs at maximum speed.

Pump release. If, after a prolonged period of inactivity, the circulation pump is blocked, unscrew the front cap and turn the motor shaft using a screwdriver. Take great care during this operation to avoid damage to the motor.

By-pass Regulation (part. 21 Fig. 1-29). The boiler leaves the factory with the by-pass open. If necessary, the by-pass can be regulated to system requirements from minimum (by-pass closed) to maximum (by-pass open). Adjust using a flat head screwdriver, turn clockwise and open the by-pass, anticlockwise it is closed.

1.27 KITS AVAILABLE ON REQUEST.

- System shut-off valve kits with or without inspection filter (on request). The boiler is designed for installation of system interception cocks to be placed on flow and return pipes of the connection assembly. This kit is very useful for maintenance because it allows to empty just the boiler without having to empty the entire system. Moreover, the version with filter preserves the functioning characteristics of the boiler thanks to its inspectionable filter.
- System zone control unit kit (on request). If the heating system is to be divided into several zones (max. three), in order to interlock them with separate adjustments and to keep water flow rate high for each zone, Immergas supplies zone system kits by request.
- External storage tank unit coupling kit (on request). If the production of DHW is required as well as room central heating, on request Immergas supplies a kit made up from an external cylinder unit and everything necessary for adaptation of the boiler.

- Polyphosphate dispenser kit (on request). The polyphosphate dispenser reduces the formation of lime-scale and preserves the original heat exchange and domestic hot water production conditions. The boiler is prepared for application of the polyphosphate dispenser kit.
- Relay board (on request). The boiler is prepared for the installation of a relay card that allows to increase the features of the appliance and therefore functioning possibilities.
- Cover kit (on request). If installed outdoors in a partially protected place with direct air intake, it is compulsory to mount the appropriate top protection cover for the correct functioning of the boiler and to protect it from adverse weather conditions.
- Cycloidal filter kit (on request). The magnetic cycloidal filter is able to detect the ferrous residues present in the system's water. Thanks to the two cocks in the kit, it facilitates maintenance by cleaning the filter without having to empty the circuit.

The above-mentioned kits are supplied complete with instructions for assembly and use.

Total head available to the system.

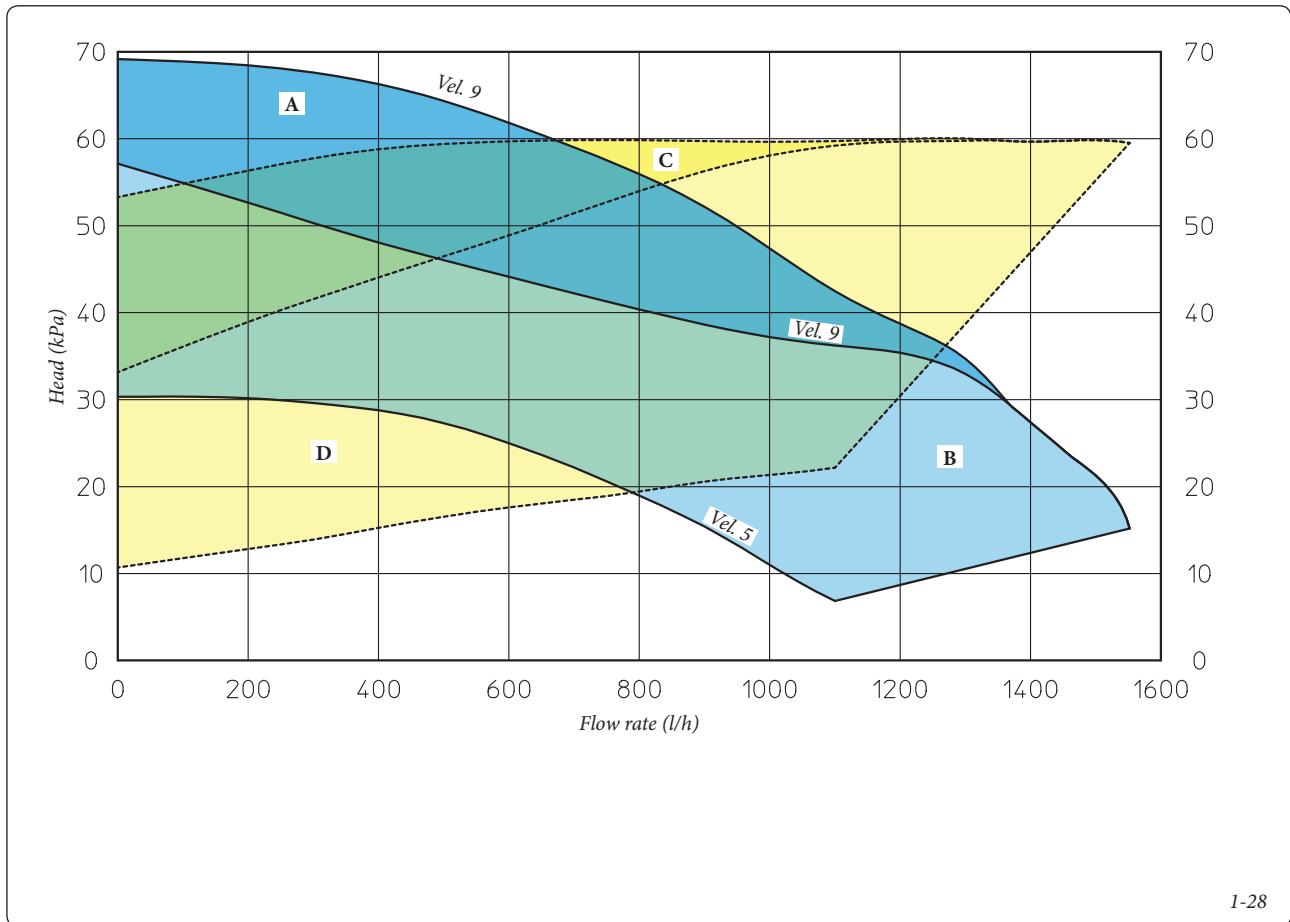

INSTALLER

USER

MAINTENANCE TECHNICIAN

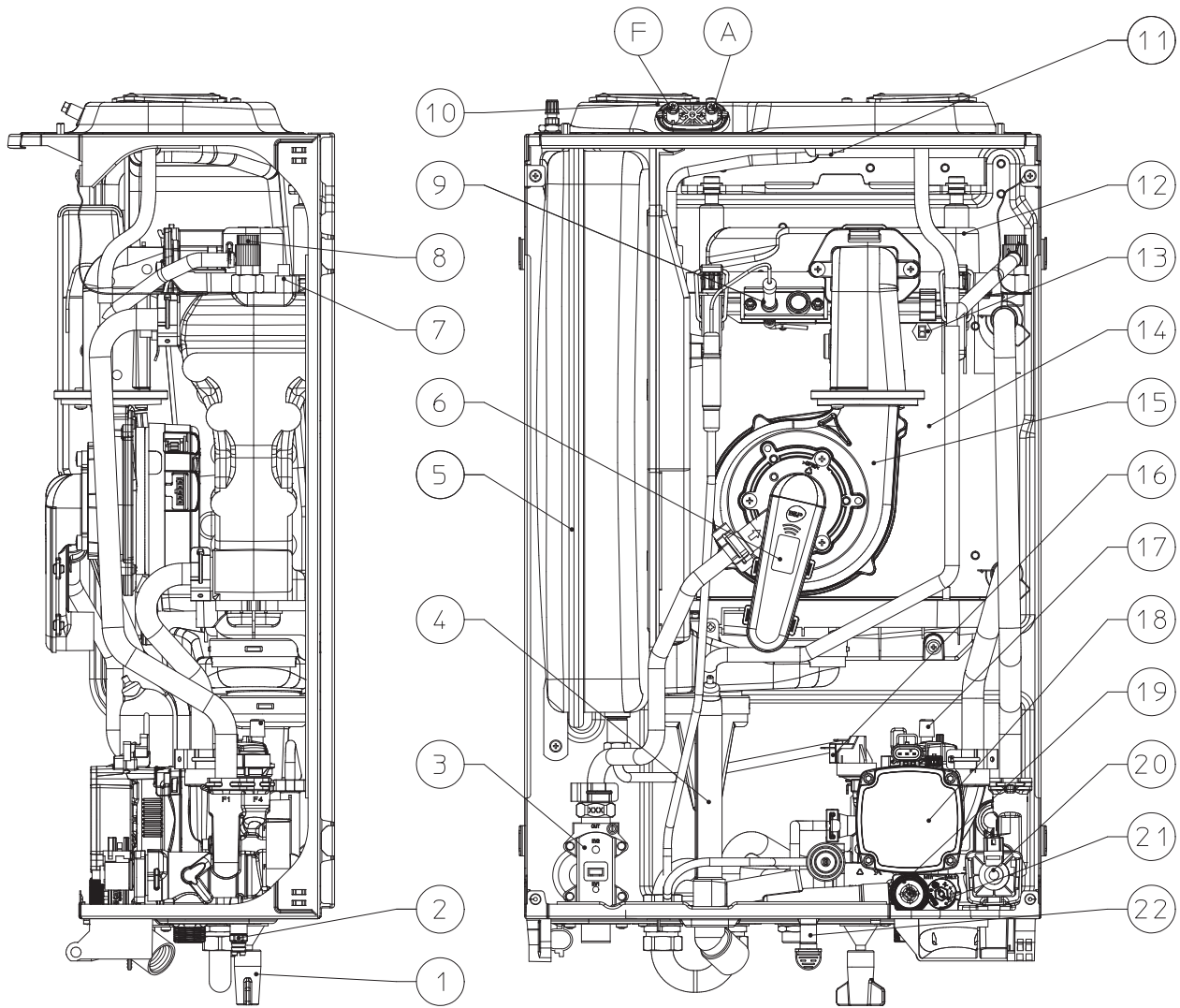

Key:

- | | |
|---|--|
| 1 - System filling valve | 12 - Burner cover |
| 2 - System draining valve | 13 - Safety flow probe |
| 3 - Gas valve | 14 - Condensation module |
| 4 - Condensate drain trap | 15 - Fan |
| 5 - System expansion vessel | 16 - System pressure switch |
| 6 - Air / gas mixer | 17 - Vent valve |
| 7 - Delivery probe | 18 - Boiler circulator pump |
| 8 - Manual air vent valve | 19 - 3 bar safety valve |
| 9 - Ignition / detection electrode | 20 - 3-way valve (motorised) |
| 10 - Sample points (air A) - (flue gas F) | 21 - By-pass |
| 11 - Flue probe | 22 - 3-bar safety valve drain fitting signal |

2 USE AND MAINTENANCE INSTRUCTIONS

2.1 CLEANING AND MAINTENANCE.

Attention: to preserve the boiler's integrity and keep the safety features, performance and reliability which distinguish it unchanged over time, maintenance operations must be carried out on a yearly basis in compliance with that stated in the "annual check and maintenance of the appliance" section, in compliance with national, regional, or local standards in force.

2.2 GENERAL WARNINGS.

Never expose the wall-mounted boiler to direct vapours from a cooking surface.

Use of the boiler by unskilled persons or children is strictly prohibited.

For safety purposes, check that the air intake/ flue exhaust terminals (if fitted) are not blocked. If temporary shutdown of the boiler is required, proceed as follows:

a) drain the heating system if antifreeze is not used;

b) shut-off all electrical, water and gas supplies.

In the case of work or maintenance to structures near ducting or devices for flue extraction and the relative accessories, switch off the appliance and on completion of the operations make sure that an authorised company verifies the efficiency of the ducting or the devices.

Never clean the appliance or connected parts with easily flammable substances.

Never leave containers or flammable substances in the same environment as the appliance.

• **Attention:** the use of components involving use of electrical power requires some fundamental rules to be observed:

- do not touch the appliance with wet or moist parts of the body; do not touch when bare-foot;
- never pull electrical cables or leave the appliance exposed to weathering (rain, sunlight, etc.);
- the appliance power cable must not be replaced by the user;

- if the cable is damaged, switch off the appliance and solely contact an authorised company to replace it;

- if the appliance is not to be used for a certain period, disconnect the main power switch.

N.B.: the temperatures indicated by the display have a tolerance of +/- 3°C due to environmental conditions that cannot be attributed to the boiler.

At the end of its service life the appliance must not be disposed of like normal household waste nor abandoned in the environment, but must be removed by a professionally authorised company. Contact the manufacturer for disposal instructions.

2.3 CONTROL PANEL.

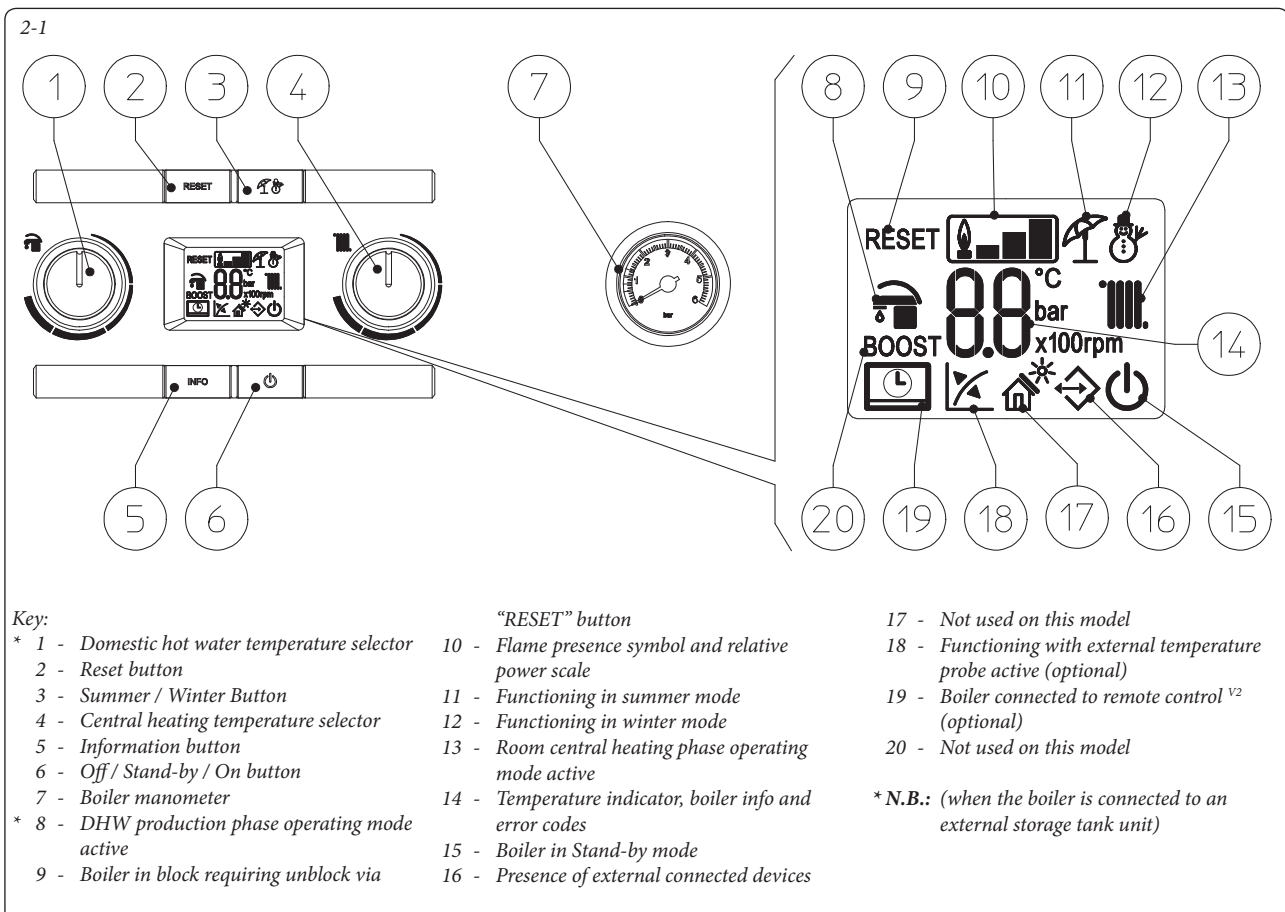

INSTALLER

USER

MAINTENANCE TECHNICIAN

2.4 USING THE BOILER.

Attention:

the Victrix 12X-20X TT 2 ErP boiler was designed to operate as an appliance for room central heating only or, coupled to a specific optional kit, for central heating and DHW production. For this reason the boiler control panel has a knob to adjust the temperature of DHW, but its operation is only activated by the optional kits that also enable the production of DHW. Without coupling to these specific kits, the functioning of this knob and all functions referring to DHW are inhibited, apart from the calibration phase and scrolling the P.C.B. programming menu.

Before ignition make sure the heating system is filled with water and that the manometer (7) indicates a pressure of $1 \div 1.2$ bar.

- Open the gas cock upstream from the boiler.
- Press the button (6) until the display switches on. The boiler now returns to the state prior to switch-off.
- If the boiler is in stand-by, press the button (6) again to activate it. If this is not the case, go to the next point.
- Then press the button (3) in sequence and set the boiler in the summer (☀) or winter (❄) position.

• **Summer** (☀): in this mode the boiler only works to produce DHW (*when the boiler is connected to the external storage tank unit*); the temperature is set via the selector (1) and the relative temperature is shown on the display via the indicator (14).

• **Winter** (❄): in this mode, the boiler works to produce DHW (*when the boiler is connected to the external storage tank unit*) as well as central heating. The temperature of the DHW is always regulated via the selector (1), the heating temperature is regulated via selector (4) and the relative temperature is shown on the display via the indicator (14).

From this moment the boiler functions automatically. With no demand for heat (central heating or domestic hot water production) the boiler goes to “standby” function, equivalent to the boiler being powered without presence of flame. Each time the burner ignites, the relative flame present symbol is displayed (10) with relative output scale.

• **Operation with Comando Amico Remoto^{V2} (CAR^{V2}) (Optional).** If the CAR^{V2} is connected, the (📶) symbol will appear on the display. The boiler regulation parameters can be set via the CAR^{V2} control panel and the reset button (2) remains active on the boiler control panel, along with the switch-off button (6) (“off” mode only) and the display where the functioning state is shown.

Caution: if the boiler is switched “off” the CAR^{V2} will display the connection error symbol “ERR>CM”, the CAR^{V2} is however powered constantly so as not to lose the stored programs.

• **Operation with optional external probe** (🌡). In the case of a system with optional external probe, the boiler flow temperature for room central heating is managed by the external probe depending on the external temperature measured (Par. 1.9). The flow temperature can be modified by selecting the functioning curve via the selector switch (4) (or on the CAR^{V2} control panel, if connected to the boiler) selecting a value from “0 to 9”.

With external probe present, the relative symbol (18) will appear on the display. In the central heating phase, if the temperature of the water contained in the system is sufficient to heat the radiators, the boiler can only function with the activation of the pump.

• **“Stand-by” mode.** Press button (6) repeatedly until the symbol (🔒) appears. From now on the boiler remains inactive and the anti-freeze function, pump anti-block function and 3-way and signalling of any anomalies is guaranteed.

N.B.: in these conditions the boiler is still powered.

• **“Off” mode.** By holding the button (6) down for 8 seconds, only the central point remains lit on the display, and the boiler is off completely. The safety functions are not guaranteed in this mode.

IMPORTANT NOTE: in these conditions the boiler is considered still live even if there are no functions active.

• **“Automatic vent” mode.** When the function is enabled, every time the boiler is electrically powered, the system automatic vent function is activated (lasting 8 minutes). This function is displayed via a countdown signalled by the indicator (14). During this period the DHW and CH functions are not active.

The “automatic vent” can be annulled by pressing the “reset” button (2).

• **Display operation.** The display lights up while the control panel is being used; after a set inactivity period, the brightness drops until only the active symbols are displayed. The lighting mode can be varied via parameter t8 in the P.C.B. programming menu.

2.5 TROUBLESHOOTING.

The Victrix 12X-20X TT 2 ErP boiler reports any anomalies via a code shown on the boiler display (14) according to the following table:

Error Code	Anomaly signalled	Cause	Boiler status / Solution
01	No ignition block	In the event of request of room central heating or domestic hot water production, the boiler does not switch on within the preset time. Upon appliance commissioning or after extended downtime, it may be necessary to eliminate the block.	Press the Reset button (1)
02	Safety thermostat block (over-temperature)	During normal operation, if a fault causes excessive overheating internally, the boiler goes into overheating block.	Press the Reset button (1)
03	Flue safety thermostat block	During normal operation, if a fault causes excessive flue gas overheating, the boiler blocks	Press the Reset button (1)
04	Contacts resistance block	The P.C.B. detects an anomaly on the gas valve supply. Check the connection. (the anomaly is detected and displayed only in the event of a request).	Press the Reset button (1)
05	Flow probe anomaly	The board detects an anomaly on the flow NTC probe.	The boiler does not start (1)

(1) If the block or anomaly persists, contact an authorised company (e.g. Technical After-Sales Service).
 (2) The anomaly can only be verified in the list of errors in the “Information” menu

Error Code	Anomaly signalled	Cause	Boiler status / Solution
08	Maximum N° of reset	Number of allowed resets that have already performed.	Attention: the anomaly can be reset 5 times consecutively, after which the function is inhibited for at least one hour. One attempt is gained every hour for a maximum of 5 attempts. By switching the appliance on and off again, the 5 attempts are re-acquired.
10	Insufficient system pressure	Water pressure inside the central heating circuit that is sufficient to guarantee the correct operation of the boiler is not detected.	Check on the boiler pressure gauge (1) that the system pressure is between 1±1.2 bar and restore the correct pressure if necessary.
12	Storage tank probe anomaly (optional)	If the P.C.B. detects a fault in the boiler probe (<i>when the boiler is connected to an external storage tank unit</i>), the boiler cannot produce DHW and signals a fault.	The boiler does not satisfy the DHW production requests (1).
15	Configuration error	If the board detects an anomaly or incongruity on the electric wiring, the boiler will not start.	If normal conditions are restored the boiler restarts without having to be reset. Check that the boiler is configured correctly (1)
16	Fan anomaly	This occurs if the fan has a mechanical or electrical fault.	Press the Reset button (1)
20	Parasite flame block	This occurs in the event of a leak on the detection circuit or anomaly in the flame control unit.	Press the Reset button (1)
24	Push button control panel anomaly	The board detects an anomaly on the pushbutton panel.	If normal conditions are restored the boiler restarts without having to be reset (1).
29	Flue probe anomaly	The board detects an anomaly on the flue gas probe	The boiler does not start (1)
31	Loss of remote control communication	This occurs if an incompatible remote control is connected, or if communication between the boiler and the remote control is lost.	Power cycle the boiler. If the Remote Control is still not detected on re-starting the boiler will switch to local operating mode, i.e. using the controls on the control panel. In this case the "Central Heating" (1) mode cannot be activated.
36	IMG Bus communication loss	Communication between the various components is interrupted due to an anomaly on the boiler control unit, on the zone control unit or on the IMG Bus.	The boiler does not satisfy the room heating requests (1).
37	Low power supply voltage	This occurs when the power supply voltage is lower than the allowed limits for the correct boiler operation.	If normal conditions are restored the boiler restarts without having to be reset (1)
38	Loss of flame signal	This occurs when the boiler is ignited correctly and the burner flame switches off unexpectedly; a new attempt at ignition is performed and if normal conditions are restored, the boiler does not have to be reset.	If normal conditions are restored the boiler restarts without having to be reset (1) (2)
43	Block due to loss of flame signal	This occurs if the "Flame signal loss" error occurs many times in a row within a preset period (38).	Press the Reset button, before restarting, the boiler will run a post-ventilation cycle. (1)
44	Block for exceeding the maximum accumulated time, close gas valve opening	This occurs if the gas valve remains open for longer than required for normal operation, without the boiler switching on.	Press the Reset button (1)
46	Low temperature safety thermostat (optional)	During normal operation, if an anomaly causes excessive overheating of the flow temperature in low temperature conditions, the boiler blocks.	In this case, after suitable cooling, it is possible to reset the thermostat (see relative instructions sheet). (1).
47	Burner power limitation	Should flue high temperature be detected, the boiler reduces power supplied so as not to damage it.	(1)
51	CAR Wireless communication failure	If there is no communication between the boiler and Wireless version CAR, an anomaly is signalled. From this moment, it is only possible to control the system by means of the control panel of the boiler itself.	Check operation of the Wireless CAR, check the battery charge (refer to the relative instructions booklet).
59	Main supply voltage frequency block	The board detects a main supply voltage frequency anomaly	The boiler does not start (1)
60	Anomaly pump blocked	The pump is stopped due to one of the following causes: Impeller blocked, electrical fault.	Try to unblock the pump as described in the relative section. If normal conditions are restored the boiler restarts without having to be reset (1)

(1) If the block or anomaly persists, contact an authorised company (e.g. Technical After-Sales Service).

(2) The anomaly can only be verified in the list of errors in the "Information" menu

Error Code	Anomaly signalled	Cause	Boiler status / Solution
61	Air in circulator pump	Air is detected inside the pump; the pump cannot work.	Vent the pump and the central heating circuit. If normal conditions are restored the boiler restarts without having to be reset (1)
62	Complete calibration required	Missing calibration is detected by the P.C.B. It may occur in the event the P.C.B. is replaced or if the parameters are altered in the air / gas section, thus requiring "complete calibration".	The boiler does not start (1)
72	Fast calibration required	The P.C.B. detects that some parameters have been altered, thus requiring "fast calibration".	The boiler does not start (1)
73	High flow probe and safety flow probe deviation detected.	The board detects an anomaly in the temperature readings of the NTC flow probes; the causes may be: faulty probe, incorrect position, poor system circulation, or clogging of the water side primary heat exchanger.	If normal conditions are restored the boiler restarts without having to be reset (1)
74	Safety flow probe anomaly	The board detects an anomaly on the NTC safety flow probe	The boiler does not start (1)
77	Combustion control anomaly	Out of range current is detected on the gas valve	The boiler does not start (1)
78	Combustion control anomaly	High current on the gas valve is detected	The boiler does not start (1)
79	Combustion control anomaly	Reduced current on the gas valve is detected	The boiler does not start (1)
80	P.C.B. malfunction block	This occurs in the event of malfunctions of the P.C.B. that controls the valve.	Press the Reset button (1)
84	Combustion anomaly - power reduction in progress	A low supply pressure is detected on the gas line. As a result the appliance power is limited and the anomaly is reported.	If normal conditions are restored the boiler restarts without having to be reset (1) (2)
87	Block - gas valve control	A malfunction of one of the components that controls the gas valve has been detected	The boiler does not start (1)
88	Block - gas valve control	A malfunction of one of the components that controls the gas valve has been detected	The boiler does not start (1)
89	Combustion signal unstable	The flame is unstable due to: presence of flue gas recirculation, wind, unstable gas pressure, unstable fan speed, or due to system malfunction	The boiler keeps working (1) (2)
90	Combustion signal beyond limit	The combustion signal is beyond the adjustment range required for an extended period of time	The boiler keeps working (1) (2)
91	Incorrect ignition block	The board has exhausted all possible actions in order to obtain optimal ignition of the burner	Press the Reset button (1)
92	Fan revs correction limit	The system has exhausted all possible corrections of the number of fan revs	The boiler keeps working (1) (2)
93	Combustion signal beyond limit	The combustion signal is beyond the adjustment range required for a limited period of time.	The boiler keeps working (1) (2)
94	Combustion anomaly	A problem is detected on the combustion control, which may be due to: gas low pressure, flue recirculation, defective gas valve or P.C.B.	If normal conditions are restored the boiler restarts without having to be reset (1) (2)
95	Combustion signal discontinuous	The system detects a discontinuous combustion signal.	The boiler keeps working (1) (2)
96	Clogged flue	This occurs in the event an obstruction is detected in the flue system.	The boiler does not start (1) If normal conditions are restored the boiler restarts without having to be reset
98	Block - maximum no. of software errors	The maximum number of software errors possible has been reached.	Press the Reset button (1)
99	General block	A boiler anomaly has been detected	Press the Reset button (1)

(1) If the block or anomaly persists, contact an authorised company (e.g. Technical After-Sales Service).
(2) The anomaly can only be verified in the list of errors in the "Information" menu

2.6 INFORMATION MENU.

By pressing the "Info" button (5), the "Information menu" is activated for at least 1 second, displaying some boiler operating parameters.

Press the "Info" button (5) to scroll the various parameters.

To exit the menu, press the "Info" button (5) up to the end of the list, or by pressing the "Reset" button (2) or by waiting for 15 minutes.

With the menu active, the indicator (14) will alternately show the indication of the parameter via the letter "d" plus the number of the parameter that is being displayed and the value of the parameter itself.

Id Parameter	Description
d 0.0	Not used
d 0.1	Displays the combustion signal
d 0.2	Displays the primary exchanger output instant heating flow temperature
d 0.3	Displays the DHW temperature of the storage tank unit (<i>when the boiler is connected to the external storage tank unit</i>)
d 0.4	Displays the values set for central heating set
d 0.5	Displays the values set for DHW set
d 0.6	Displays the external environment temperature (if optional external probe present) If the temperature is below zero, the value is displayed flashing.
d 0.7	Not used
d 0.8	Not used
d 09	Displays the list of the last five anomalies. (to scroll the list, turn the CH temperature selector (4))
d 1.0	Anomaly list reset. Once "d 1.0" is displayed, press the Reset button; deletion is confirmed via the "88" symbols flashing for two seconds.
d 1.1	Displays the temperature read on the safety flow probe
d 1.2	Displays the pump operating speed
d 1.3	Not used
d 1.4	Displays the pump flow rate (lh/100)
d 1.5	Displays the fan operating speed (rpm/100)
d 1.6	Displays the temperature read on the flue probe

2.7 BOILER SHUTDOWN

Switch the boiler off by putting it in "off" mode, disconnect the onnipolar switch outside of the boiler and close the gas cock upstream from the appliance. Never leave the boiler switched on if left unused for prolonged periods.

2.8 RESTORING CENTRAL HEATING SYSTEM PRESSURE.

Periodically check the system water pressure. The boiler pressure gauge should read a pressure between 1 and 1.2 bar.

If the pressure falls below 1 bar (with the circuit cold) restore normal pressure via the valve located at the bottom of the boiler (Fig. 1-3).

N.B.: close the cock after the operation.

If pressure values reach around 3 bar the safety valve may be activated.

In this case, remove water from an air vent valve of a radiator until 1 bar is reached or ask for assistance from an authorised company.

In the event of frequent pressure drops, contact a qualified firm for assistance to remove any system leakage.

2.9 SYSTEM DRAINING.

To drain the boiler, use the special draining valve (Fig. 1-3).

Before draining, ensure that the filling cock is closed.

2.10 ANTI-FREEZE PROTECTION.

The "Victrix 12X-20X TT 2 ErP" series boiler features an antifreeze function that lights the burner automatically when the temperature falls below 4°C (standard protection down to min. temperature of -5°C). All information relative to the anti-freeze protection is stated in Par. 1.3. In order to guarantee the integrity of the appliance and the domestic hot water heating system in zones where the temperature falls below zero, we recommend the central heating system is protected using anti-freeze liquid and installation of the Immergas Anti-freeze Kit in the boiler. In the case of prolonged inactivity (second case), we also recommend that:

- disconnect the electric power supply;
- the central heating circuit and boiler domestic hot water circuit must be drained. In systems that are drained frequently, filling must be carried out with suitably treated water to eliminate hardness that can cause lime-scale.

2.11 CASE CLEANING.

Use damp cloths and neutral detergent to clean the boiler casing. Never use abrasive or powder detergents.

2.12 DECOMMISSIONING.

In the event of permanent shutdown of the boiler, contact an authorised company for the suitable procedures and also ensure the electrical, water and fuel supply lines are shut off and disconnected.

3 BOILER COMMISSIONING (INITIAL CHECK)

To commission the boiler:

- ensure that the type of gas used corresponds to the boiler settings (the type of gas appears on the display on first electrical power supply, or by checking the relative parameter "G");
- check connection to a 230V-50Hz power mains, correct L-N polarity and the earthing connection;
- make sure the central heating system is filled with water and that the pressure gauge indicates a pressure of 1-1.2 bar.
- switch the boiler on and check correct ignition;

- check the CO₂ flow rate in the flue:
 - maximum (100%)
 - intermediate (50%)
 - minimum (0%)
 the values must comply with what is indicated in the relative tables (Fig. 3-14);
- check activation of the safety device in the event of no gas, as well as the relative activation time;
- check the intervention of the main switch located upstream of the boiler and in the boiler;
- check that the intake and/or exhaust terminals are not blocked;
- ensure activation of all adjustment devices;

- check the production of DHW (when the boiler is connected to an *external storage tank unit*);
- check sealing efficiency of water circuits;
- check ventilation and/or aeration of the installation room where provided.

If even only a single safety check offers a negative result, do not commission the system.

3.1 BOILER HYDRAULIC DIAGRAM.

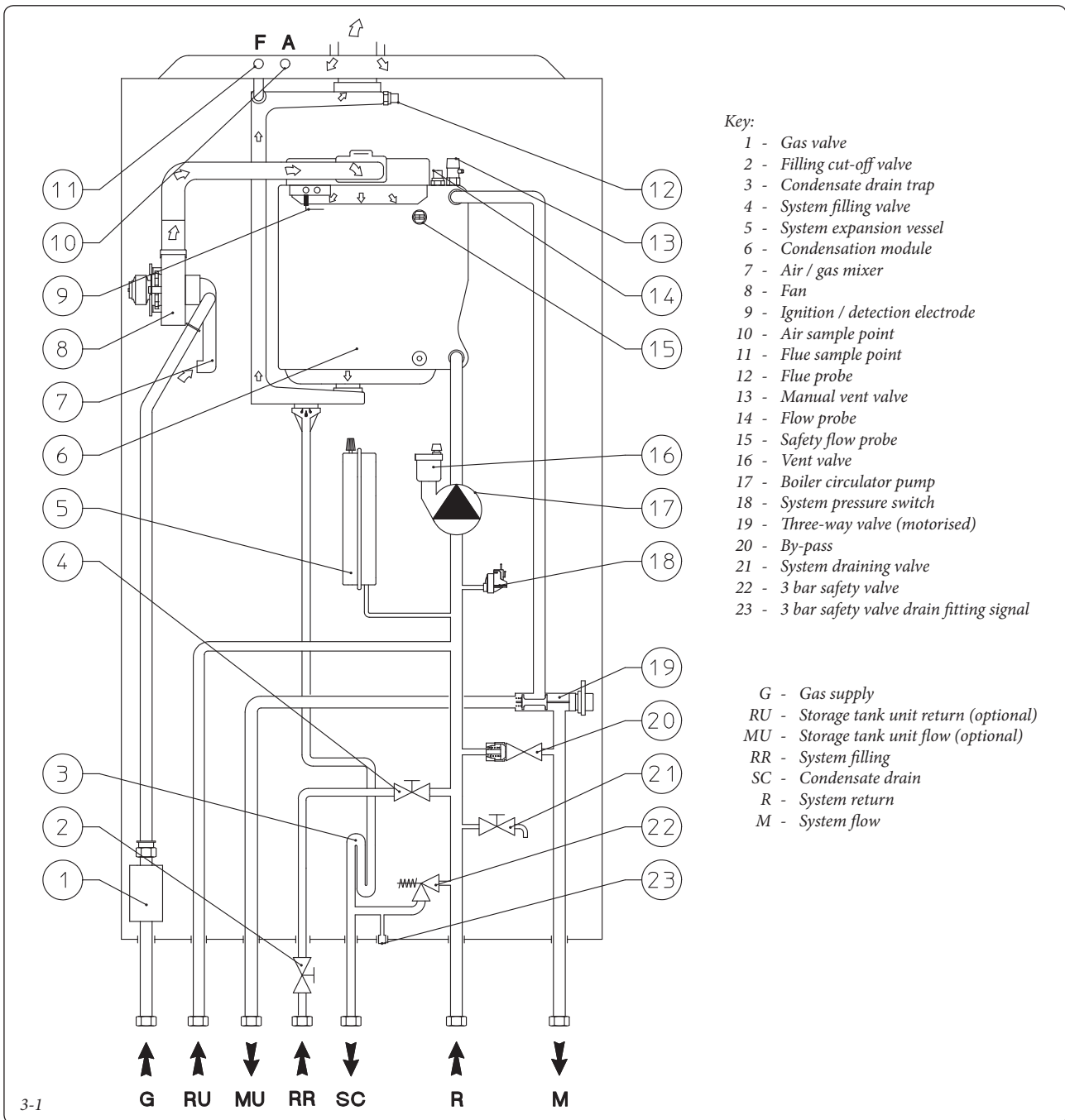

3.2 WIRING DIAGRAM.

3-2

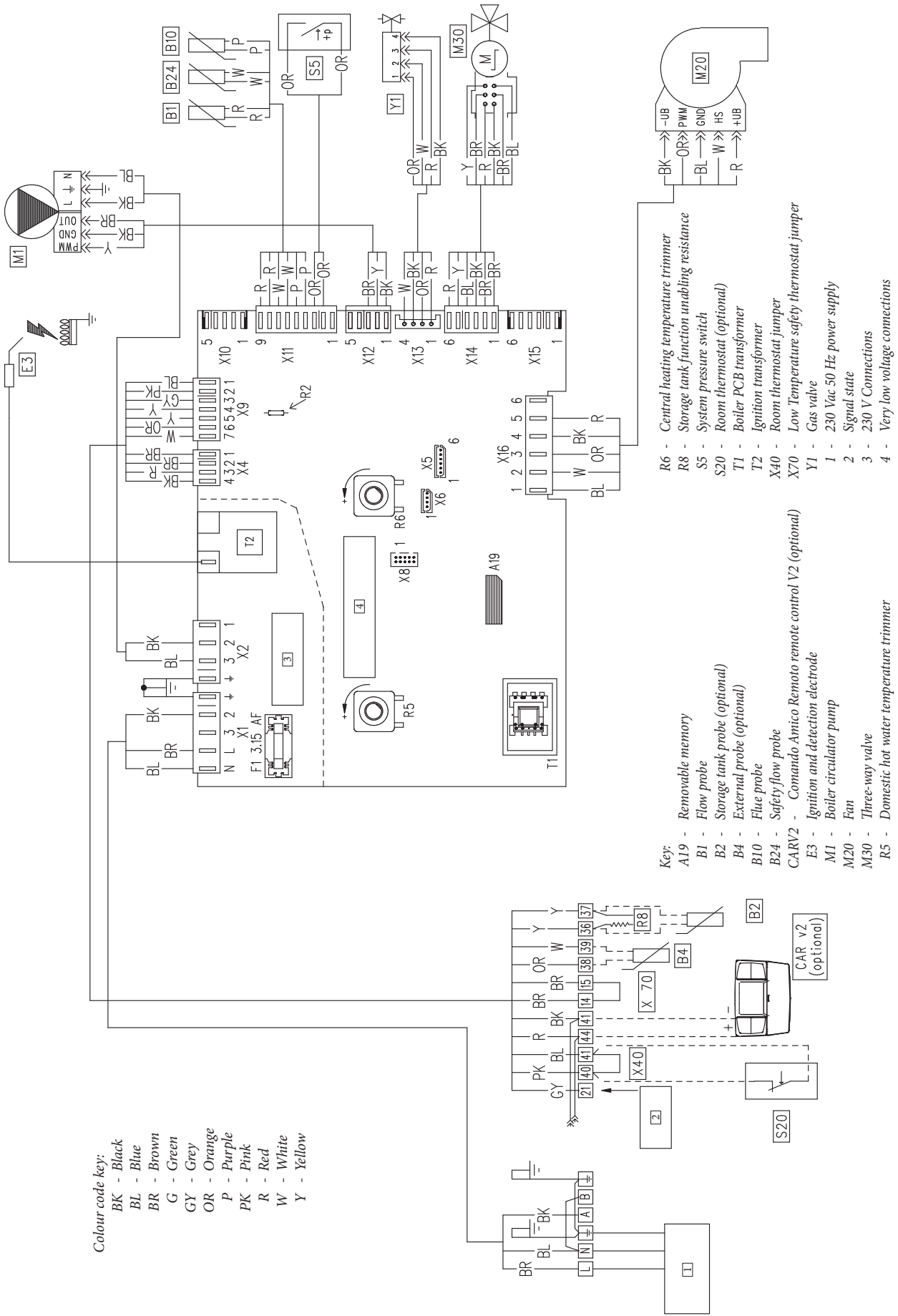

INSTALLER

USER

MAINTENANCE TECHNICIAN

Comando Amico Remoto^{V2}: the boiler is prepared for the application of the Comando Amico Remoto remote control ^{V2} (CAR^{V2}), which must be connected to clamps 41 and 44 of the terminal board (located in the boiler control panel) respecting the polarity and eliminating jumper X40.

Room thermostat: the boiler is prepared for the application of the room thermostat (S20), which must be connected to clamps 40 and 41 of the terminal board (located in the boiler control panel Para. 1.7) eliminating jumper X40.

Storage tank unit: the boiler is prepared for connection to a storage tank unit, which must be connected to clamps 36 and 37 of the terminal board (located in the boiler control panel, Para 1.7) eliminating resistance R8.

The connector X5 is used for the connection to the relay board.

The connector X6 is for connection to a personal computer.

The connector X8 is used for software updating operations.

3.3 REMOVABLE MEMORY

The P.C.B. is equipped with a removable memory (2 Fig. 3-4), which records all operation parameters and system customisations.

Should the P.C.B. be replaced, you can use the memory of the replaced board again, so it is not necessary to reconfigure the appliance.

Attention: replacing the memory must be carried out after disconnecting all electrical connection of the P.C.B.

3.4 TROUBLESHOOTING.

N.B.: maintenance interventions must be carried out by an authorised company (e.g. Authorised After-Sales Technical Assistance Service).

- Smell of gas. Caused by leakage from gas circuit pipelines. Check sealing efficiency of gas intake circuit.
- Repeated ignition blocks. No gas, check the presence of pressure in the network and that the gas adduction cock is open.
- Irregular combustion or noisiness. It may be caused by: a dirty burner, incorrect combustion parameters, intake-exhaust terminal not correctly installed. Check the above components.
- Non-optimal ignition of first ignition of the burner: even if the burner is perfectly calibrated, first ignition of the burner (after calibration) can be sub-optimal; the system automatically regulates ignition until it finds optimal ignition of the said burner.
- Frequent interventions of the overheating safety thermostat. It can depend on the lack of water in the boiler, little water circulation in the system or blocked pump. Check on the manometer that the system pressure is within established limits. Check that the radiator valves are not closed and also the functionality of the pump.
- Drain trap clogged. This may be caused by dirt or combustion products deposited inside. Check that there are no residues of material blocking the flow of condensate.
- Heat exchanger clogged. This may be caused by the drain trap being blocked. Check that there are no residues of material blocking the flow of condensate.

- Noise due to air in the system. Check opening of the special air vent valve cap (Part. 17 Fig. 1-29). Make sure the system pressure and expansion vessel pre-charge values are within the set limits; The factory-set pressure values of the expansion vessel must be 1.0 bar, the value of system pressure must be between 1 and 1.2 bar.
- Noise due to air inside the condensation module. Use the manual air vent valve (Part. 8 Fig. 1-29) to eliminate any air present in the condensation module. When the operation has been performed, close the manual vent valve.
- Poor production of D.H.W. (when the boiler is connected to an external storage tank unit). If a drop in performance is detected during supply of D.H.W., it is possible that the condensation module is clogged. In this case, contact After-Sales Assistance Service that has procedures to clean the module or D.H.W. heat exchanger.

3.5 CONVERTING THE BOILER TO OTHER TYPES OF GAS.

If the boiler has to be converted to a different type of gas to that specified on the data nameplate, proceed as follows:

The gas conversion operation must be carried out by an authorised company (e.g. After-Sales Technical Assistance Service).

To convert to another type of gas the following operations are required:

- Select, via programming menu "G", the type of gas by selecting "nG" for methane gas and "LG" for LPG gas. (See par. 3.12).
- Carry out complete calibration (see par. 3.8); during the procedure check and, if necessary, correct the air - gas ratio.
- Upon completing the conversion, apply the sticker regarding the modified gas content onto the data nameplate in the connection box.

These adjustments must be made with reference to the type of gas used, following that given in the table (Par. 3.22).

3.6 CHECKS FOLLOWING CONVERSION TO ANOTHER TYPE OF GAS.

After having made sure that the conversion is complete and that the calibration has been successful, you must make sure that:

- there is no flame in the combustion chamber
- the burner flame is not too high or low and that it is stable (does not detach from burner)
- the pressure testers used for calibration are perfectly closed and there are no leaks from the gas circuit.

IMPORTANT NOTE: all boiler adjustment operations must be carried out by a qualified company (e.g. Authorised After-Sales Assistance).

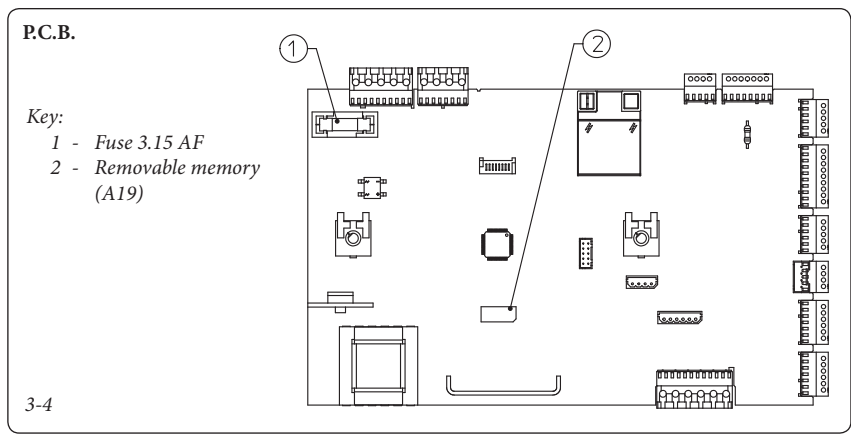
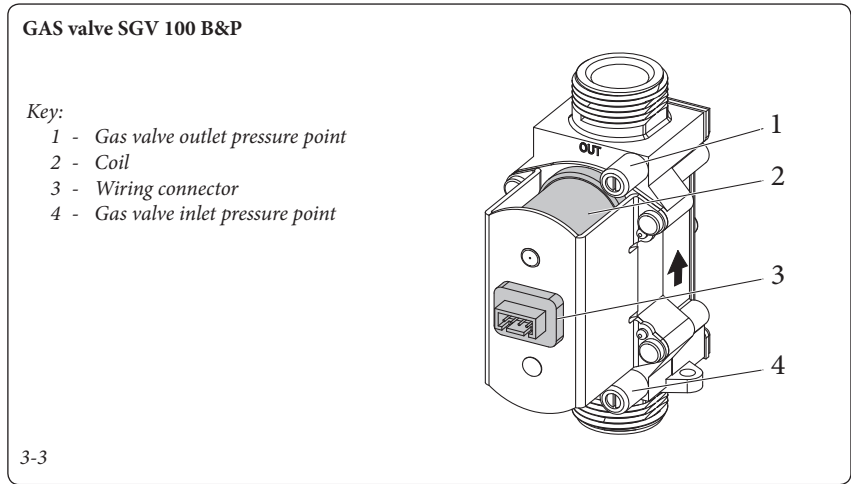

3.7 CALIBRATION TYPE INVOLVING THE REPLACEMENT OF A COMPONENT.

When performing extraordinary maintenance on the boiler, involving the replacement of a component, such as the P.C.B. (if the removable memory is not put into the replacement board) or components in the air, gas and flame control circuits, the boiler will need to be calibrated. Select the type of calibration to be carried out according to the table below.

Replaced component	Type of calibration required
Gas valve	Quick calibration
Fan	Quick calibration
Burner	Complete calibration with air-gas ratio check
Ignition/detection electrodes	Complete calibration with air-gas ratio check
P.C.B. (New virgin P.C.B. without removable memory recovery)	Restore the parameters as described in the paragraph "P.C.B. programming" Complete calibration with air-gas ratio check
P.C.B. (Recovery of the removable memory with the boiler parameters set from the replaced board)	No calibration required.

3.8 COMPLETE CALIBRATION FUNCTION.

N.B.: before carrying out complete calibration, ensure that all the requirements indicated in paragraphs 1.23 and 1.24 have been fulfilled.

IMPORTANT NOTE: to access this function it is crucial that there are no active requests for central heating or DHW production. In the event of anomaly "62" or "72" (see parag. 2.6) the boiler cancels any requests by itself.

N.B.: during the various calibration stages, the air - gas ratio can be checked and possibly corrected as described in par. 3.9.

The energy produced is dissipated via the heating circuit; alternatively, the energy can be released from the DHW circuit by opening any hot water tap.

Caution: in this case the only active temperature control is the flow probe that limits the maximum temperature exiting the boiler at 90°C, therefore be careful not to get burned.

- The calibration procedure involves various stages:
 - nominal heat output calibration;
 - intermediate heat output ignition calibration;
 - minimum heat output calibration;
 - calibration self-check.

Each calibration procedure, if carried out without altering the parameters, lasts 5 minutes at the most, after which it switches automatically to the next parameter until the calibration process is complete.

In order to access the complete calibration stage, you must switch the boiler on, set the DHW selector in the "6 o' clock" position and the heating selector in the "9 o' clock" position, (Fig. 3-5) and press the "Reset" button for about 8 seconds until the "chimney sweep" function is activated; then press the "summer / winter" button within 3 seconds.

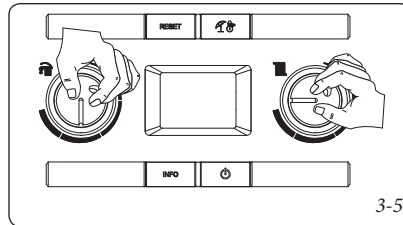

- **Nominal heat output:** with the function active, the boiler carries out the procedures required to calibrate the appliance at the nominal heat output.

At this stage the display features flashing icons: "summer", "winter", "stand-by" and the operating temperature alternated with the current operating heat output (99%); once the parameters are detected and stabilised, the frame of the flame presence symbol (ref. 10 fig. 2-1) will start flashing (this procedure may last a few minutes), meaning that the nominal heat output parameters have been set.

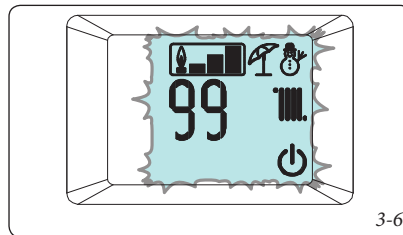

The air - gas ratio can only be corrected after the flame presence frame has flashed (see parag. 3.9) or switch to the next heat output parameter by pressing the "info" button.

- **Intermediate heat output ignition:** once the nominal heat output calibration is confirmed, the boiler is calibrated with the intermediate heat output (or ignition heat output).

At this stage the display features flashing icons: "summer", "winter", "stand-by" and the operating temperature alternated with the current operating heat output (typically 41% but variable according to the boiler model); once the parameters are detected and stabilised, the frame of the flame presence symbol will start flashing, meaning that the intermediate heat output parameters have been set.

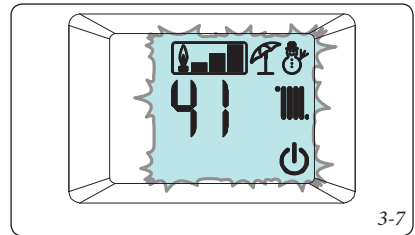

The air - gas ratio can only be corrected after the flame presence frame has flashed (see parag. 3.9) or switch to the next heat output parameter by pressing the "info" button.

- **Minimum heat output:** after having calibrated the boiler with the intermediate heat output, it is calibrated with the minimum heat output.

At this stage the display features flashing icons: "summer", "winter", "stand-by" and the operating temperature alternated with the current operating heat output (0%); once the parameters are detected and stabilised, the frame of the flame presence symbol will start flashing, meaning that the minimum heat output parameters have been set.

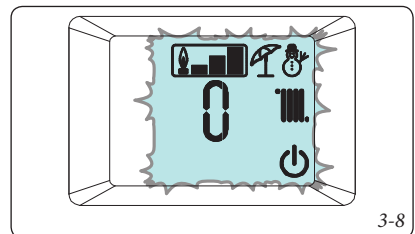

The air - gas ratio can only be corrected after the flame presence frame has flashed (see parag. 3.9) or exit the calibration mode by pressing the "summer / winter" button.

- **Calibration self-check:** once calibration operations are complete, the boiler runs a self-check for about one minute. During this check, the boiler can run at different powers and it is not possible to apply modifications to the operating parameters or to delete the operation in progress. Moreover, it is important not to cut the boiler's power.

3.9 ADJUSTING THE AIR GAS RATIO

During complete calibration (par. 3.8), you can modify the values of the air - gas ratio.

To have an exact value of CO₂ in the flue, the technician must insert the sampling probe to the bottom of the sample point, then check that the CO₂ value is that specified in the table (Par. 3.23), (with maximum tolerance equal to $\pm 0.2\%$); otherwise, modify the value as described below:

- During calibration, when the flame presence starts flashing (indicating the correct acquisition of the parameters) it is possible to alter the CO₂ value by pressing the "Reset" button. At this stage the display features flashing icons: "summer", "winter", "stand-by", "flame presence", "external connected devices presence" and the operating temperature is displayed, alternated with the combustion setting.

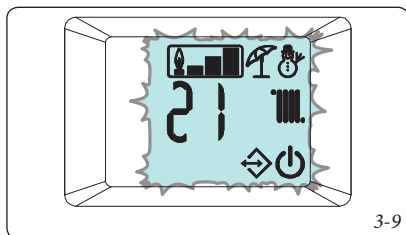

3-9

- To increase the combustion setting, press the "Stand-by" button; to decrease it, press the "Info" button. As the combustion setting increases, the CO₂ value decreases and vice-versa.
- Once the parameter has been altered wait for the value to be saved (displayed via the frame of the flame presence symbol flashing).
- To confirm the set value press the "Reset" button.

3.10 FAST CALIBRATION.

This function allows you to calibrate the boiler automatically without requiring or giving the possibility to alter the parameters. Typically "fast calibration" is used after having set the type of flue in menu "F", which once altered causes anomaly "72".

N.B.: before performing a quick calibration, ensure that all the requirements indicated in paragraphs 1.21 and 1.22 have been fulfilled.

IMPORTANT NOTE: to access this function it is crucial that there are no active requests for central heating or DHW production.

In the event of anomaly "62" or "72" (see parag. 2.6) the boiler cancels any requests by itself.

The energy produced is dissipated via the heating circuit; alternatively, the energy can be released from the DHW circuit by opening any hot water tap.

Caution: in this case the only active temperature control is the flow probe that limits the maximum temperature exiting the boiler at 90°C, therefore be careful not to get burned.

In order to access the fast calibration stage, set the DHW selector in the "6 o' clock" position and the heating selector in the "9 o' clock" position, (Fig. 3-10) and press the "Reset" button for about 8 seconds until the "chimney sweep" function is activated; then press the "info" button within 3 seconds.

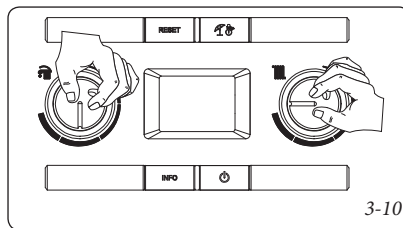

3-10

Once the function is active, the boiler sequentially carries out the procedures required to calibrate the appliance with the nominal, intermediate and minimum heat output values.

At this stage the display features flashing icons: "summer", "winter", "stand-by", "external probe", "solar probe" and the operating temperature is displayed, alternated with the current operating heat output.

The calibration stages (nominal, intermediate and minimum) progress automatically and you must wait until calibration is complete.

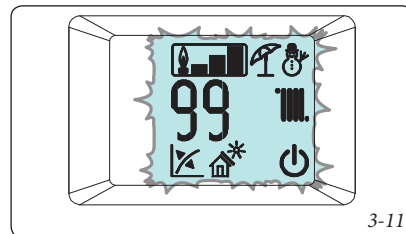

3-11

3.11 FLUE TEST.

Warning: this operation must not be carried out on the Victrix 12 X TT 2 ERP model.

To define the value to set in the "flue length" "F0" parameter, detect the parameters during the "flue test".

Attention: before performing the test, ensure that the condensate drain trap has been filled correctly and check that there are no obstructions in the air intake circuit and flue exhaust.

Once the test has been carried out properly, note the detected value in the relevant table, in order to have it available for future checks.

To activate this mode, the boiler must be in "stand-by" mode, which is visible when the (⏻) symbol appears.

IMPORTANT NOTE: if the boiler is connected to the CAR^{v2} the "stand-by" function can only be activated via the remote control panel.

To activate the function, press the "Reset" (2) and "on/off" (6) buttons simultaneously until function activation, which is displayed by indicating the fan operation speed (in hundreds of revs) and ignition of the flashing "D.H.W." (8) and central heating symbols.

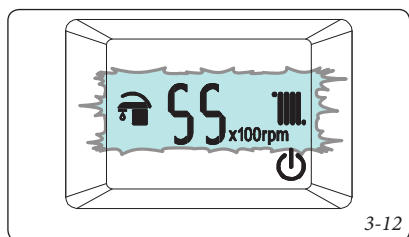

3-12

The appliance remains in this mode for a maximum period of 15 minutes, keeping the fan speed constant.

This function ends once 15 minutes have elapsed, or by disconnecting supply voltage to the boiler, or by pressing the "on/off" (6) button for approximately 8 seconds.

Check the ΔP between the test pressures (fig. 1-29 Ref. 10), in compliance with the values indicated in the following tables:

Victrix 20X TT 2 ErP	
Parameter F0	Pressure
0	< 145 Pa
1	146 ÷ 178 Pa
2	179 ÷ 205 Pa
Detected value (upon first check)	

N.B.: examinations are carried out by sealing the holes provided to analyse the flues, making them pneumatically sealed.

Attention: should there be a boiler malfunction, you can carry out a flue test to check that there are no obstructions in the flue system. Different values to those indicated in the previous tables indicate a flue system malfunction, especially a flue system with excessive load losses or obstructed system.

3.12 PROGRAMMING THE P.C.B.

The boiler is prepared for possible programming of several operation parameters. By modifying these parameters as described below, the boiler can be adapted according to specific needs.

To access the programming stage, set the DHW selector in the "6 o' clock" position and the heating selector in the "9 o' clock" position and press the "Reset" and "Summer/Winter" buttons for about 8 seconds (Fig. 3-13).

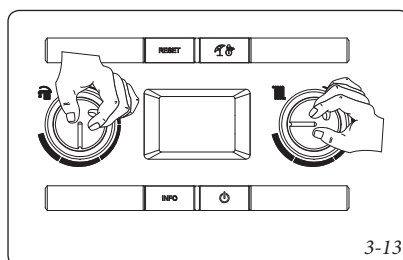

3-13

Once the programming mode has been accessed, scroll through the five menus (G, P, t, A, F) by pressing the "Summer / Winter" button for 1 second.

Use the "D.H.W. regulator" selector to select the parameter (within the same sub-menu) and rotate the "C.H. regulator" selector to alter the value.

Press the "Reset" button for 1 second to store the altered parameters.

If the parameters are stored successfully, "88" appears on the indicator (Ref. 14 fig. 2-1) for 2 seconds.

Exit the programming mode by waiting for 15 minutes or by pressing the "Reset" and "Summer/Winter" buttons at the same time.

Attention: if necessary the default values relating to parameters "S" and "P0 ÷ P2" can be altered by temporarily modifying the type of gas (parameter "G") and by restoring it according to the actual operating conditions (wait for approximately 10 seconds between the gas change and the when it is restored).

The restored values will be those relating to the type of boiler set in parameters "n" and "F".

At the end of this operation, anomaly "E62" will appear and complete calibration will be required.

- **Menu "G":** This menu is reserved for the air-gas control settings and it features two sub-menus (n and S), relating to fan and gas valve control settings. Every time these parameters are altered, the complete calibration function must be activated (see par. 3.8). In order to access parameters "n" and "S" press the "Reset" button sequentially. In order to exit this part of the menu and access other parts (categories P, t, A, F) press the "Summer / winter" button.

Id Parameter	Parameter	Description	Range	Default	Customised value
G		Defines operation with methane gas	nG	nG	
		Defines operation with LPG gas	LG		
In the event of an alteration, anomaly "E62" appears and complete calibration is required.					

Id Parameter	Parameter	Description	Range	Default	Customised value
n	Boiler model	Define the boiler model	0 ÷ n	04=Victrix 12X TT 2 ErP 02=Victrix 20X TT 3 ErP	
Caution: only use the parameter relating to the boiler installed.					
In the event of an alteration, anomaly "E62" appears and complete calibration is required.					

Id Parameter	Parameter	Description	Range	Default	Customised value
S0	Min output	The P.C.B. defines the operating mode and the boiler output according to the combination of several parameters. The proper operating output of the appliance is defined according to the combination of the parameters of menus "n" and "F". For this reason it is recommended not to alter the parameters of this menu in order not to compromise the proper operation of the boiler.	750 ÷ 1700 rpm	according to the boiler model	
S1	Max output		50 ÷ 6900 rpm		
S2	Ignition output		2000 ÷ 4500 rpm		
In the event of an alteration, anomaly "E62" appears and complete calibration is required.					

Id Parameter	Parameter	Description	Range	Default	Customised value
P0	DHW max	Defines the maximum heat output percentage of the boiler during the D.H.W. phase compared to the maximum heat output available	0 - 99 %	99%	
P1	Min output	Defines the minimum heat output percentage of the boiler compared to the minimum heat output available	0 - P2	0%	
P2	Heating max	Defines the maximum heat output percentage of the boiler during the central heating mode compared to the maximum heat output available	0 - 99%	according to the boiler model	
P3	Relay 1 (optional)	The boiler is set-up for functioning with the relay P.C.B. (optional), which can be configured 0 = Off 1 = Main zone control 2 = General alarm 3 = CH phase active 4 = External gas valve power supply 5 = (Do not use on this boiler model) 6 = (Do not use on this boiler model) 7 = (Do not use on this boiler model)	0 - 7	1	
P4	Relay 2 (optional)	The boiler is set-up for functioning with the relay P.C.B. (optional), which can be configured 0 = Off 1 = General alarm 2 = CH phase active 3 = External gas valve power supply 4 = Secondary zone control (from TA on relay P.C.B. contact) 5 = Heat pump 6 = (Do not use on this boiler model) 7 = (Do not use on this boiler model)	0 - 7	0	
P5	Relay 3 (optional)	The boiler is set-up for functioning with the relay P.C.B. (optional), which can be configured 0 = Off 1 = Chiller remote activation 2 = General alarm 3 = CH phase active 4 = External gas valve power supply 5 = heat pump 6 = activation of storage tank pump 7 = Main zone control 8 = (Do not use on this boiler model) 9 = (Do not use on this boiler model).	0 - 9	0	
P6	Pump functioning	The pump can function in two ways. 0 intermittent: in winter "mode" the circulator is managed by the room thermostat or by the remote control 1 continuous: in "winter" mode the circulator is always powered and is therefore always in operation	0 - 1	0	
P7	External probe correction	If the reading of the external probe is not correct it is possible to correct it in order to compensate any environmental factors. (Over the value of +9 the display shows "CE", which enables an external control function of the boiler for coupling of the same with a system supervisor)	-9 ÷ 9 K	0	
P8	-	Not used on this boiler model	-	-	

Id Parameter	Parameter	Description	Range	Default	Customised value
t0	Central heating set point minimum temperature	Defines the minimum flow temperature.	20 ÷ 50 °C	25	
t1	Central heating set point maximum temperature	Defines the maximum flow temperature.	(t0+5) ÷ 85 °C	85	
t2	DHW thermostat	Establishes the ignition and switch-off method of the boiler in DHW phase (<i>when the boiler is connected to an external storage tank unit</i>). 0 - Ignition occurs when the water contained in the storage tank drops by 3°C with respect to the temperature set and switches off when the temperature is at the value set (solar activated) 1 - Ignition occurs when the water contained in the storage tank drops by 2°C with respect to the temperature set and switches off when the temperature is at +1°C with respect to the value set (solar deactivated) 2 - Ignition occurs when the water contained in the storage tank drops by 10°C with respect to the temperature set and switches off when the temperature is at the value set (solar activated) 3 - Ignition occurs when the water contained in the storage tank drops by 5°C with respect to the temperature set and switches off when the temperature is at the value set (solar activated)	0 On = -3°C Off = +0°C 1 On = -2°C Off = +1°C 2 On = -10°C Off = +0°C 3 On = -5°C Off = +0°C	2	
t3	Solar delay timing	This function does not affect the correct functioning of this boiler model.	0 - 30 seconds	0	
t4	Domestic hot water priority timing	This function does not affect the correct functioning of this boiler model.	0 - 100 seconds (step 10 sec)	2	
t5	Central heating ignitions timer	The boiler has electronic timing, which prevents the burner from igniting too often in central heating mode	0 - 600 seconds (step 10 sec)	18	
t6	Central heating ramp timer	In the heating stage, the boiler performs an ignition ramp in order to reach the maximum output set	0 - 840 seconds (step 10 sec)	18	
t7	CH ignition delay from TA and CR request	The boiler is set to switch-on immediately after a request. In the event of particular systems (e.g. area systems with motorised thermostatic valves etc.) it may be necessary to delay ignition	0 - 600 seconds (step 10 sec)	0	
t8	Display lighting	Establishes the display lighting mode. 0 Automatic: the display lights up during use and dims after 15 seconds of inactivity. In the event of an anomaly the display flashes. 1 Low: the display is always lit with low intensity 2 High: the display is always lit with high intensity.	0 - 2	0	
t9	Display	Establishes what the indicator displays 14 (Fig. 2-1). "Summer" mode: 0: the indicator is always off 1: circulator active, it displays the flow temperature pump off the indicator is off "Winter" mode: 0: it always displays the value set on the central heating selector 1: circulator active, it displays the flow temperature pump off always displays the value set on the CH selector	0 - 1	1	

INSTALLER

USER

MAINTENANCE TECHNICIAN

Id Parameter	Parameter	Description	Range	Default	Customised value
A0	Hydraulic model	Defines the type of hydraulics in the boiler	Set 2	2	
A1	-	Not used on this boiler model	-	-	
A2	Model Pump	Defines the type of circulator in the boiler	Set 0	0	
A3	Maximum pump speed	Sets the maximum pump operating speed	1 ÷ 9	9	
A4	Minimum pump speed	Sets the minimum pump operating speed	1 ÷ A3	5	
A5	Pump operating mode	Sets the pump operating mode	Set 0	0	
A7	Ignition phase automatic vent	Sets the activation mode of the automatic vent at each new electric powering phase of the boiler. This function lasts 8 minutes, and is displayed via a countdown signalled by the special indicator (Ref. 14 Fig. 2-1). During this period the DHW and CH functions are not active. The "automatic vent" function can be annulled by pressing the "reset" button. 1: the automatic vent is enabled at each new electric power supply. 0: the automatic vent is enabled only at the first electric power supply after having set the parameter to "0"; once the function has ended, or is interrupted by pressing the "reset" button, it will not be enabled again unless the parameter is set to "1".	0 - 1	1	

Id Parameter	Parameter	Description	Range	Default	Customised value
F0	Equivalent length flue	Defines the length of the flue (see par. 3.11)	0 - 2	0	
F1	-	Not used on this boiler model	-	-	
In the event of an alteration, anomaly "E72" appears and fast calibration is required.					

3.13 SOLAR PANELS COUPLING FUNCTION.

The boiler is set-up to receive water. In the event of integration of DHW heating with solar panel systems, the boiler is set by default for management of the storage tank unit via parameter "t2" set on "2" (Par. 3.12).

3.14 "CHIMNEY SWEEP" FUNCTION.



When activated, this function forces the boiler to variable output for 15 minutes.

In this state all adjustments are excluded and only the safety thermostat and the limit thermostat remain active. To activate the chimney sweep function, press the "Reset" button (2) until activation of the function in the absence of DHW requests.

Its activation on the boiler display is confirmed by the indicators flashing at the same time (11 and 12 Fig. 2-1), while on the CAR^{v2} (optional) it is indicated as "ERR>07".

This function allows the technician to check the combustion parameters.

Once the function is activated, it is possible to select whether to make the check in CH status or DHW status (*when the boiler is connected to an external storage tank unit*) by opening any hot water cock and regulating the power by turning the "CH regulation" selector (6).

The central heating or DHW operating mode is displayed by the relative symbols  or .

After the checks, deactivate the function switching the boiler off and then on again.

Attention: the boiler needs a certain amount of time to stabilise itself before carrying out a combustion parameters check. It is thus necessary to wait for the boiler to carry out a self-diagnosis test, which is signalled by the  flashing symbol. Once the symbol stops flashing, it is possible to check the combustion parameters.

3.15 PUMP ANTI-BLOCK FUNCTION.

The boiler has a function that starts the pump at least once every 24 hours for the duration of 30 seconds in order to reduce the risk of the pump becoming blocked due to prolonged inactivity.

3.16 THREE-WAY ANTI-BLOCK FUNCTION.

Both in "domestic hot water" and in "domestic hot water-central heating" phase the boiler is equipped with a function that starts the three-way motorised group 24 hours after it was last in operation, running it for a full cycle so as to reduce the risk of the three-way group becoming blocked due to prolonged inactivity.

3.17 RADIATORS ANTIFREEZE FUNCTION.

If the system return water is below 4°C, the boiler starts up until reaching 42°C.

3.18 P.C.B. PERIODIC SELF-CHECK.

During functioning in central heating mode or with boiler in standby, the function activates every 18 hours after the last boiler check/power supply. In case of functioning in domestic hot water mode the self-check starts within 10 minutes after the end of the withdrawing in progress, for duration of approx. 10 seconds.

N.B.: during self-check, the boiler remains off.

3.19 AUTOMATIC VENT FUNCTION.

In the case of new central heating systems and in particular mode for floor systems, it is very important that deaeration is performed correctly. The function consists of the cyclic activation of the pump (100 s ON, 20 s OFF) and the 3-way valve (120 s D.H.W., 120 s C.H.).

The function is activated in two different ways:

- at each new boiler power supply, based on the setting of parameter "A7";
- by pressing the buttons at the same time (3 and 5 Fig. 2-1) for 5 seconds with the boiler in stand-by.

IMPORTANT NOTE: if the boiler is connected to the CAR^{v2} the "stand-by" function can only be activated via the remote control panel.

In the first case, the function has duration of 8 minutes and it can be interrupted by pressing the "reset" button (2). In the second case it has duration of 18 hours and it can be interrupted by simply switching the boiler on.

Activation of the function is signalled by the countdown shown on the indicator (14).

3.20 YEARLY APPLIANCE CHECK AND MAINTENANCE.

The following checks and maintenance should be performed at least once a year.

- Check that the system's water PH is between 6.5 and 8.5.
- Visually check for water leaks or oxidation from/on fittings and traces of condensate residues inside the sealed chamber.
- Check contents of the condensate drain trap.
- Check that there are no residues of material clogging the condensate passage; also check that the entire condensate drainage circuit is clear and efficient.
- Visually check that the water safety drain valve is not clogged.
- Check that, after discharging system pressure and bringing it to zero (read on boiler pressure gauge), the expansion vessel pressure is at 1.0 bar.
- Check that the system static pressure (with system cold and after refilling the system by means of the filling valve) is between 1 and 1.2 bar.
- Visually check that the safety and control devices have not been tampered with and/or short-circuited.
- Check the condition and integrity of the electrical system and in particular:
 - supply voltage cables must be inside the fairleads;
 - there must be no traces of blackening or burning.
- Check ignition and operation.
- Check correct calibration of the burner in domestic hot water and central heating phases.
- Check the operation of the appliance control and adjustment devices and in particular:
 - system regulation probes intervention;
 - the intervention of the DHW adjustment thermostat (*when the boiler is connected to an external storage tank unit*).

- Check sealing efficiency of the gas circuit and the internal system.
- Verify the intervention of the ionisation flame control no gas device:
- Check the CO₂ by using the chimney sweep function at the three reference heat outputs and using the parameters in Fig. 3-14. Should values out of the indicated tolerance range be detected, check the integrity of the ignition / detection electrode and, if required, change it, also changing the relative gasket. At this point, activate the "complete calibration" function.
- Carry out the flue test. Values below 40% compared to the pressures detected upon first check, suggest a clogged burner or module (flue side).

Attention: the burner does not need to be opened for normal maintenance of the appliance. However, should it be removed, you must change the gasket.

IMPORTANT NOTE: in addition to yearly maintenance, you must also check the thermal system and energy efficiency, with the frequency and procedures that comply with the technical regulations in force.

Victrix 12X TT 2 ErP			
	CO ₂ at nominal output	CO ₂ at intermediate output	CO ₂ at minimum output
G 20	9.30 ± 0.80	9.00 ± 0.80	9.00 ± 0.80
G 31	10.10 ± 1.00	10.00 ± 1.00	10.00 ± 1.00

Victrix 20X TT 2 ErP			
	CO ₂ at nominal output	CO ₂ at intermediate output	CO ₂ at minimum output
G 20	9.20 ± 0.80	9.00 ± 0.80	9.00 ± 0.80
G 31	10.20 ± 1.00	10.00 ± 1.00	10.00 ± 1.00

N.B.: measurements and calibration must be carried out by using regularly-calibrated instruments.

3.21 CASING REMOVAL.

To facilitate boiler maintenance the casing can be completely removed as follows:

• **Lower grid (Fig. 3-15a).**

- 1) Loosen the two screws (a);
- 2) Press the hooks inwards, which block the lower grid (b).
- 3) remove the grid (b).

• **Front panel (Fig. 3-15b).**

- 4) Remove the cover caps (c) and loosen screws (d).
- 5) Pull the front panel (e) towards you and release it from its lower seat.

• **Front (Fig. 3-15c).**

- 6) Loosen the two screws (g).
- 7) Pull the front (f) slightly towards you.
- 8) Release front (f) from pins (h) pulling it towards you while pushing it upwards at the same time.

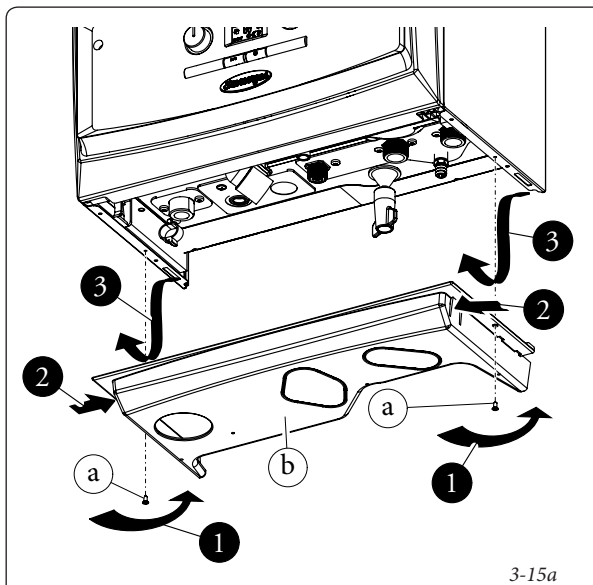

3-15a

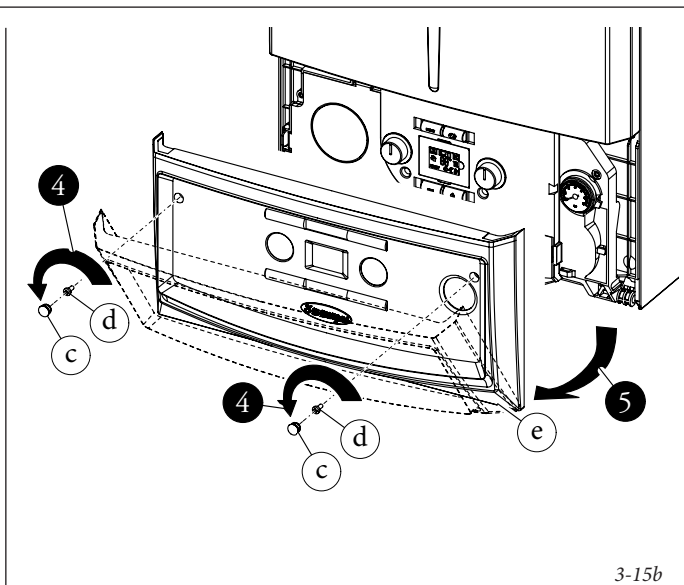

3-15b

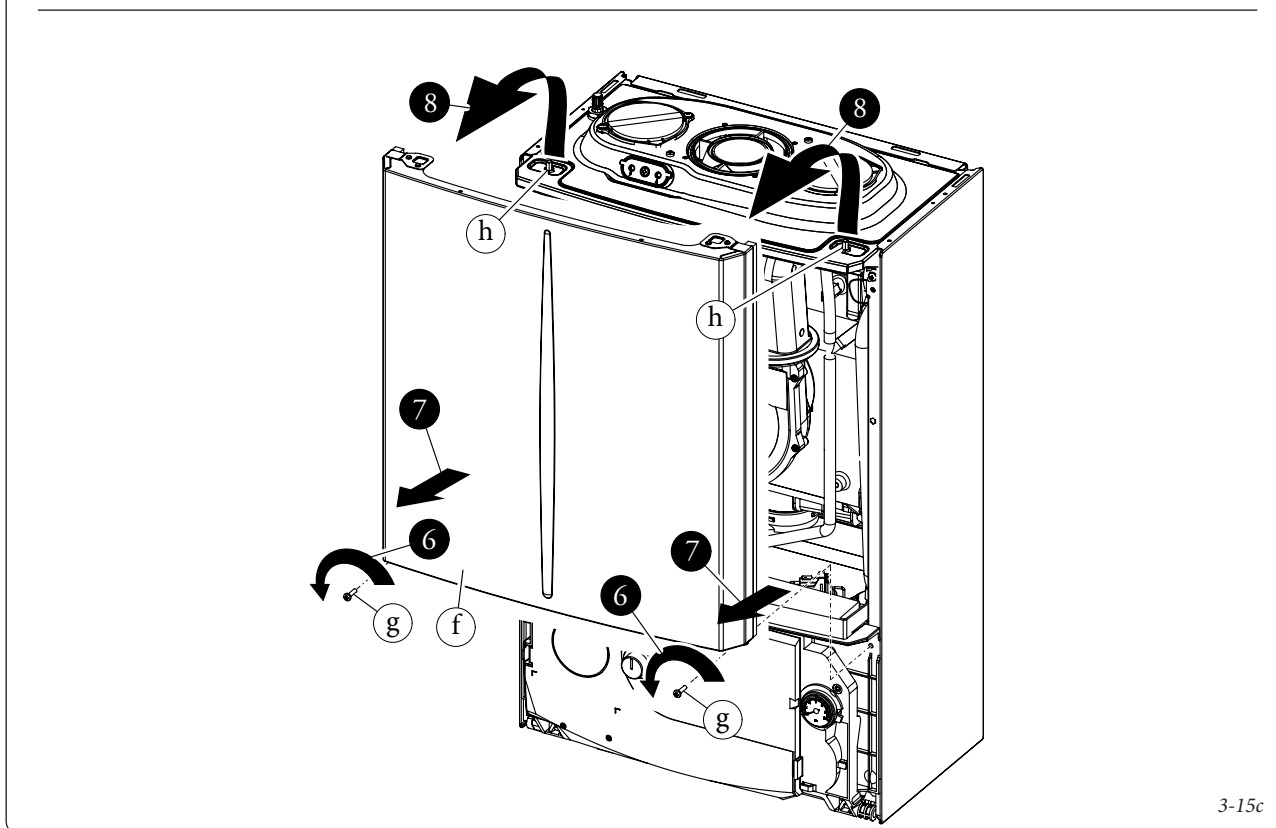

3-15c

• Control panel (Fig. 3-15d).

- 9) Press the hooks on the side of the control panel (i).
- 10) Tilt the control panel (i) towards you.

• Sides (Fig. 3-15e).

- 11) Loosen screws (k) of side fastening (j).
- 12) Remove the sides by extracting them from their rear seat (Ref. X).

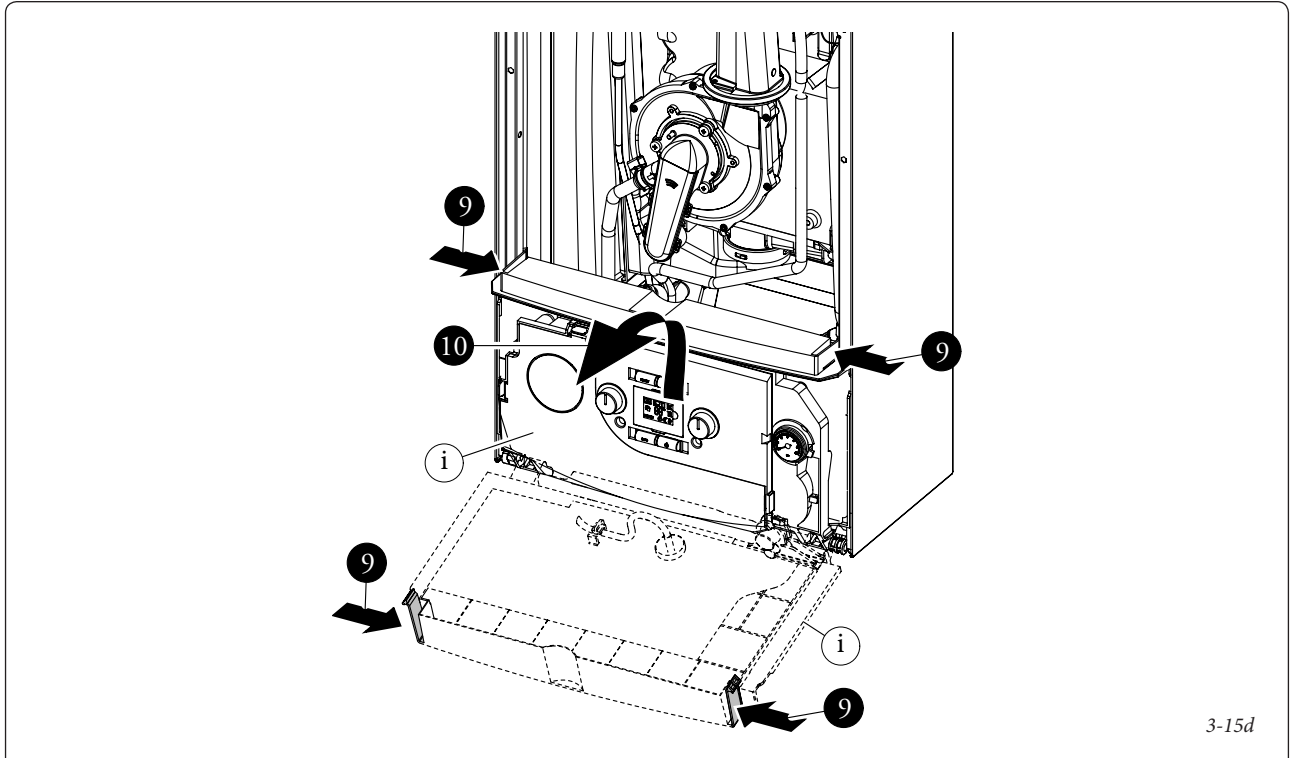

3-15d

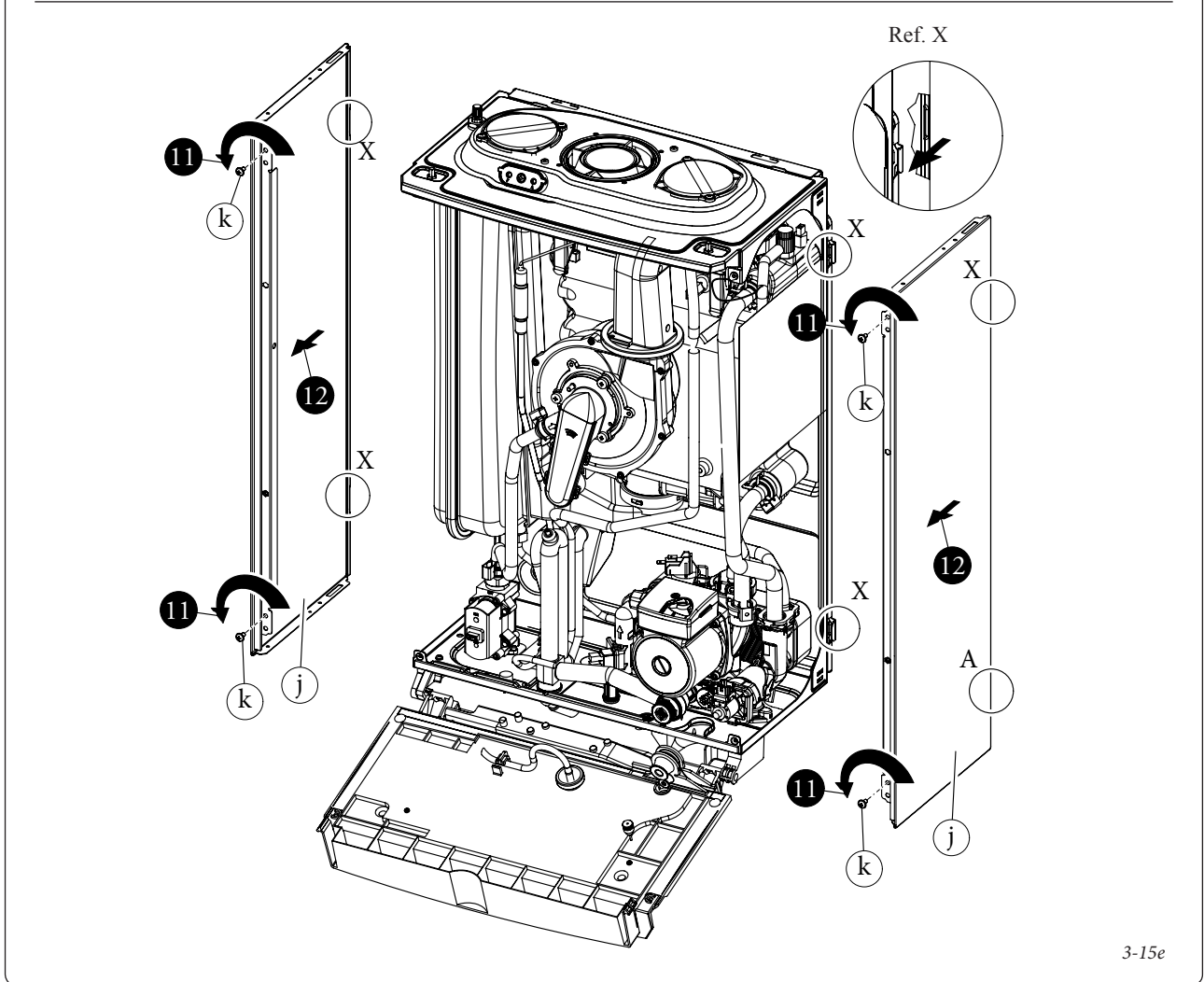

3-15e

INSTALLER

USER

MAINTENANCE TECHNICIAN

STD.002571/004

3.22 VARIABLE HEAT OUTPUT.

N.B.: the power data in the table has been obtained with intake-exhaust pipe measuring 0.5 m

in length. Gas flow rates refer to net heating value below a temperature of 15°C and at a pressure of 1013 mbar.

Victrix 12X TT 2 ErP.

			METHANE (G20)	PROPANE (G31)
THERMAL POWER	THERMAL POWER	MODULATION	BURNER GASFLOW RATE	BURNER GASFLOW RATE
(kW)	(kcal/h)	(%)	(m ³ /h)	(kg/h)
12,0	10320	99	1,30	0,96
11,0	9460	90	1,19	0,87
10,0	8600	80	1,08	0,79
9,0	7740	71	0,97	0,71
8,0	6880	61	0,86	0,63
7,0	6020	51	0,76	0,55
6,0	5160	41	0,65	0,48
5,0	4300	31	0,54	0,40
4,0	3440	21	0,43	0,32
3,0	2580	11	0,32	0,24
1,9	1634	1	0,21	0,16

Victrix 20X TT 2 ErP

			METHANE (G20)	PROPANE (G31)
THERMAL POWER	THERMAL POWER	MODULATION	BURNER GASFLOW RATE	BURNER GASFLOW RATE
(kW)	(kcal/h)	(%)	(m ³ /h)	(kg/h)
20,6	17716	85	2,25	1,65
20,0	17200	82	2,18	1,60
19,0	16340	78	2,07	1,52
18,0	15480	74	1,96	1,44
17,0	14620	69	1,85	1,36
16,0	13760	64	1,74	1,28
15,0	12900	60	1,63	1,20
14,0	12040	55	1,52	1,12
13,0	11180	50	1,41	1,04
12,0	10320	46	1,30	0,96
11,0	9460	41	1,19	0,88
10,0	8600	36	1,09	0,80
9,0	7740	31	0,98	0,72
8,0	6880	26	0,87	0,64
7,0	6020	21	0,76	0,56
6,0	5160	16	0,65	0,48
5,0	4300	11	0,54	0,40
4,0	3440	5	0,43	0,32
3,0	2580	1	0,32	0,24

3.23 COMBUSTION PARAMETERS.

		G20	G31
Supply pressure	mbar (mm H ₂ O)	20 (204)	37 (377)
Victrix 12X TT 2 ErP			
Gas nozzle diameter	mm	3,60	3,60
Flue flow rate at nominal heat output	kg/h	20	20
Flue flow rate at min heat output	kg/h	3	3
CO ₂ at Q. Nom./Min.	%	9,30 / 9,00 ± 0,2	10,20 / 10,00 ± 0,3
CO with 0% O ₂ at Nom./Min. Q. Nom./Min.	ppm	55 / 10	105 / 10
NO _x at 0% of O ₂ at Q. Nom./Min.	mg/kWh	33 / 24	34 / 29
Flue temperature at nominal output	°C	52	51
Flue temperature at minimum output	°C	47	47
Victrix 20X TT 2 ErP			
Gas nozzle diameter	mm	5,15	5,15
Flue flow rate at nominal heat output	kg/h	35	36
Flue flow rate at min heat output	kg/h	5	5
CO ₂ at Q. Nom./Min.	%	9,10 / 9,00 ± 0,2	10,10 / 10,00 ± 0,3
CO with 0% O ₂ at Nom./Min. Q. Nom./Min.	ppm	115 / 10	205 / 10
NO _x at 0% of O ₂ at Q. Nom./Min.	mg/kWh	35 / 20	30 / 25
Flue temperature at nominal output	°C	69	75
Flue temperature at minimum output	°C	53	56

Combustion parameters: measuring conditions of useful efficiency (flow temperature/return temperature= 80/60 °C), ambient temperature reference = 15°C.

INSTALLER

USER

MAINTENANCE TECHNICIAN

3.24 TECHNICAL DATA.

INSTALLER

USER

MAINTENANCE TECHNICIAN

		Victrix 12X TT 2 ErP	Victrix 20X TT 2 ErP
Nominal heat input	kW (kcal/h)	12,3 (10575)	21,3 (18318)
Minimum heat input	kW (kcal/h)	2,0 (1753)	3,1 (2630)
Nominal heat output (useful)	kW (kcal/h)	12,0 (10320)	20,6 (17716)
Minimum heat output (useful)	kW (kcal/h)	1,9 (1634)	3,0 (2580)
** Efficiency 80/60 Nom./Min.	%	97,6 / 98,0	96,9 / 98,1
** Efficiency 50/30 Nom./Min.	%	105,4 / 108,0	101,2 / 108,6
** Efficiency 40/30 Nom./Min.	%	107,0 / 109,6	104,6 / 109,1
Casing losses with burner On/Off (80-60°C)	%	0,94 / 0,60	0,54 / 0,10
Heat loss at flue with burner On/Off (80-60°C)	%	0,02 / 1,8	0,01 / 3,0
Central heating circuit max. operating pressure	bar	3	3
Maximum heating temperature	°C	90	90
Adjustable heating temperature (max operation field)	°C	20 - 85	20 - 85
System expansion vessel total volume	l	5,8	5,8
Expansion vessel factory-set pressure	bar	1,0	1,0
Appliance water content	l	1,9	1,9
Head available with 1000 l/h flow rate	kPa (m H ₂ O)	37,2 (3,8)	37,2 (3,8)
* Hot water production useful heat output	kW (kcal/h)	12,3 (10575)	21,3 (18318)
* Domestic hot water adjustable temperature	°C	10 - 60	10 - 60
* Domestic hot water circuit min. pressure (dynamic)	bar	0,3	0,3
* Domestic hot water circuit max. operating pressure	bar	10	10
* Flow rate capacity in continuous duty (ΔT 30°C)	l/min	-	12,2
Weight of full boiler	kg	33,9	33,9
Weight of empty boiler	kg	32,0	32,0
Electrical connection	V/Hz	230 / 50	230 / 50
Nominal power absorption	A	0,63	0,69
Installed electric power	W	90	90
Pump absorbed power	W	59	59
EEL	-	≤ 0,20 - Part. 3	≤ 0,20 - Part. 3
Fan power absorbed power	W	19	22
Equipment electrical system protection	-	IPX5D	IPX5D
Max temperature of combustion products	°C	75	75
Max. flue overheating temperature	°C	120	120
NO _x class	-	6	6
Weighted NO _x	mg/kWh	26,0	28,0
Weighted CO	mg/kWh	18,0	20,4
Type of appliance	C13 / C13x / C33 / C33x / C43 / C43x / C53 / C63 / C83 / C93 / C93x / B23 / B23p / B33		
Category	II 2H3P		

- The data relating to domestic hot water performance refer to a dynamic inlet pressure of 2 bar and an inlet temperature of 15°C; the values are measured immediately at the boiler outlet, considering that to obtain the data declared, mixing with cold water is required.
- * When the boiler is connected to an external storage tank unit.
- ** Yields refer to the lower heating value.

3.25 KEY FOR DATA NAMEPLATE.

Md		Cod. Md	
Sr N°	CHK	Cod. PIN	
Type			
Q _{nw} /Q _n min.	Q _{nw} /Q _n max.	P _n min.	P _n max.
PMS	PMW	D	TM
NO _x Class			
			CONDENSING

N.B.: the technical data is provided on the data plate on the boiler

	ENG
Md	Model
Cod. Md	Model code
Sr N°	Serial Number
CHK	Check
Cod. PIN	PIN code
Type	Type of installation (ref. CEN TR 1749)
Q _{nw} min.	Minimum DHW heat input
Q _n min.	CH minimum heat input
Q _{nw} max.	DHW maximum heat input
Q _n max.	CH maximum heat input
P _n min.	Minimum heat output
P _n max.	Maximum heat output
PMS	Maximum system pressure
PMW	Maximum domestic hot water pressure
D	Specific flow rate
TM	Maximum operating temperature
NO _x Class	NO _x Class
CONDENSING	Condensing boiler

3.26 TECHNICAL PARAMETERS FOR COMBINATION BOILERS (IN COMPLIANCE WITH REGULATION 813/2013).

Efficiencies in the following tables refer to the higher heating value.

Model/s:				Victrix 12 X TT 2 ErP				
Condensing boiler:				YES				
Low-temperature boiler:				NO				
B1 boiler:				NO				
Cogeneration space heater:				NO			Equipped with a supplementary heater:	NO
Combination heater:				NO				
Item	Symbol	Value	Unit	Item	Symbol	Value	Unit	
Rated heat output	P_n	12	kW	Seasonal space heating energy efficiency	η_s	93	%	
For boiler space heaters and boiler combination heaters: useful heat output				For boiler space heaters and boiler combination heaters: Useful efficiency				
At rated heat output and high-temperature regime (*)	P_4	12,0	kW	At rated heat output and high-temperature regime (*)	η_4	88,3	%	
At 30 % of rated heat output and low-temperature regime (**)	P_1	4,0	kW	At 30 % of rated heat output and low-temperature regime (**)	η_1	98,2	%	
Auxiliary electricity consumption				Other items				
At full load	el_{max}	0,019	kW	Standby heat loss	P_{stby}	0,045	kW	
At part load	el_{min}	0,013	kW	Ignition burner power consumption	P_{ign}	0,000	kW	
In standby mode	P_{SB}	0,005	kW	Emissions of nitrogen oxides	NO_x	24	mg / kWh	
For combination heaters:								
Declared load profile				Water heating energy efficiency				
				η_{WH}				
				%				
Daily electricity consumption				Daily fuel consumption				
Q_{elec}				Q_{fuel}				
Contact details								
IMMERGAS S.p.A. VIA CISA LIGURE, 95 - 42041 BRESCELLO (RE) ITALY								
(*) High-temperature regime means 60 °C return temperature at heater inlet and 80 °C feed temperature at heater outlet.								
(**) Low temperature means for condensing boilers 30 °C, for low-temperature boilers 37 °C and for other heaters 50 °C return temperature.								

Model/s:				Victrix 20 X TT 2 ErP				
Condensing boiler:				YES				
Low-temperature boiler:				NO				
B1 boiler:				NO				
Cogeneration space heater:				NO			Equipped with a supplementary heater:	NO
Combination heater:				YES				
Item	Symbol	Value	Unit	Item	Symbol	Value	Unit	
Rated heat output	P_n	21	kW	Seasonal space heating energy efficiency	η_s	93	%	
For boiler space heaters and boiler combination heaters: useful heat output				For boiler space heaters and boiler combination heaters: Useful efficiency				
At rated heat output and high-temperature regime (*)	P_4	20,6	kW	At rated heat output and high-temperature regime (*)	η_4	87,8	%	
At 30 % of rated heat output and low-temperature regime (**)	P_1	6,9	kW	At 30 % of rated heat output and low-temperature regime (**)	η_1	97,6	%	
Auxiliary electricity consumption				Other items				
At full load	el_{max}	0,016	kW	Standby heat loss	P_{stby}	0,045	kW	
At part load	el_{min}	0,012	kW	Ignition burner power consumption	P_{ign}	0,000	kW	
In standby mode	P_{SB}	0,005	kW	Emissions of nitrogen oxides	NO_x	25	mg / kWh	
For combination heaters:								
Declared load profile				Water heating energy efficiency				
				η_{WH}				
				%				
Daily electricity consumption				Daily fuel consumption				
Q_{elec}				Q_{fuel}				
Contact details								
IMMERGAS S.p.A. VIA CISA LIGURE, 95 - 42041 BRESCELLO (RE) ITALY								
(*) High-temperature regime means 60 °C return temperature at heater inlet and 80 °C feed temperature at heater outlet.								
(**) Low temperature means for condensing boilers 30 °C, for low-temperature boilers 37 °C and for other heaters 50 °C return temperature.								

3.27 PRODUCT FICHE (IN COMPLIANCE WITH REGULATION 811/2013).

Victrix 12X TT 2 ErP

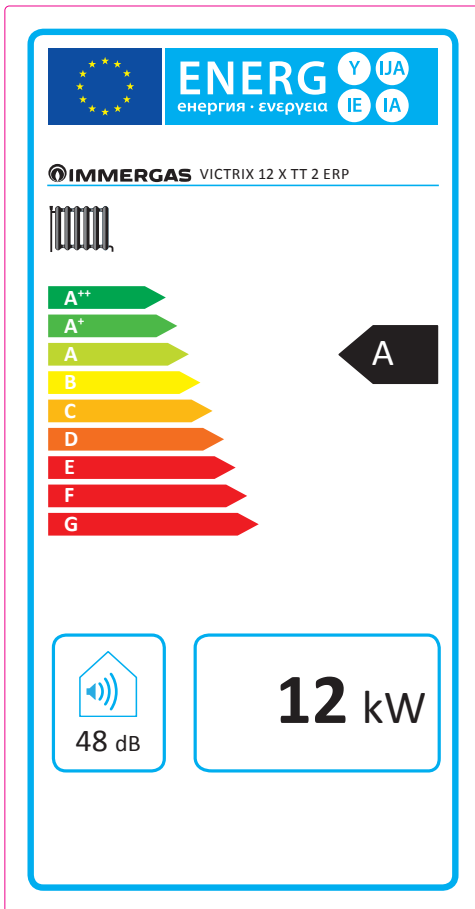

Victrix 20X TT 2 ErP

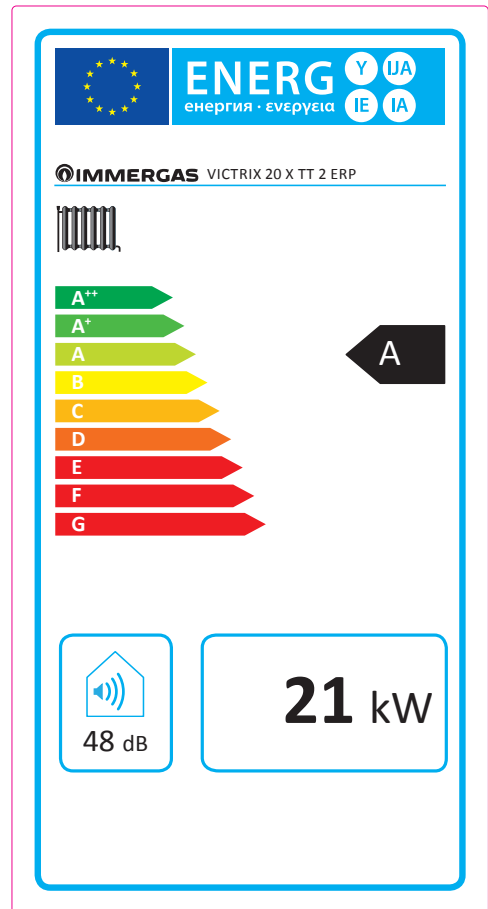

Parameter	value
Annual energy consumption for the heating function (Q_{HE})	21,6 GJ
Annual electricity consumption for the domestic hot water function (AEC)	--
Annual fuel consumption for the domestic hot water function (AFC)	--
Seasonal space heating energy efficiency (η_s)	93 %
Water heating energy efficiency (η_{wh})	--

Parameter	value
Annual energy consumption for the heating function (Q_{HE})	36,6 GJ
Annual electricity consumption for the domestic hot water function (AEC)	--
Annual fuel consumption for the domestic hot water function (AFC)	--
Seasonal space heating energy efficiency (η_s)	93 %
Water heating energy efficiency (η_{wh})	--

For proper installation of the appliance refer to chapter 1 of this booklet (for the installer) and current installation regulations. For proper maintenance refer to chapter 3 of this booklet (for the maintenance technician) and adhere to the frequencies and methods set out herein.

3.28 PARAMETERS FOR FILLING IN THE PACKAGE FICHE.

In case you should wish to install an assembly, starting from the Victrix 12X-20X TT 2 ErP boiler, use the assembly charts in fig. 3-18 and 3-21. For correctly filling in, enter the figures shown in tables fig. 3-17 and 3-20 (as shown in the facsimile assembly sheet fig. 3-16 and 3-19).

The remaining values must be obtained from the technical data sheets of the products used to make up the assembly (e.g. solar devices, integration heat pumps, temperature controllers). Use sheet fig. 3-18 for "assemblies" related to the heating function (e.g.: boiler + temperature controller).

Use sheet fig. 3-21 for "assemblies" related to the domestic hot water function (e.g.: boiler + solar thermal system).

Facsimile for filling in the package fiche for preferential boiler space heaters.

Seasonal space heating energy efficiency of boiler 1 %

Temperature control 2

From fiche of temperature control +

Class I = 1 %, Class II = 2 %,
 Class III = 1.5 %, Class IV = 2 %,
 Class V = 3 %, Class VI = 4 %,
 Class VII = 3.5 %, Class VIII = 5 %

Supplementary boiler 3

From fiche of boiler = ±

Seasonal space heating energy efficiency (in %)

$$(\text{ } - \text{'I'}) \times 0.1 = \pm \text{ } \%$$

Solar contribution 4

From fiche of solar device +

Collector size (in m²)

Tank volume (in m³)

Collector efficiency (in %)

Tank rating
A* = 0.95, A = 0.91,
B = 0.86, C = 0.83,
D-G = 0.81

$$(\text{'III'} \times \text{ } + \text{'IV'} \times \text{ }) \times (0.9 \times (\text{ } / 100)) \times \text{ } = + \text{ } \%$$

Supplementary heat pump 5

From fiche of heat pump =

Seasonal space heating energy efficiency (in %)

$$(\text{ } - \text{'I'}) \times \text{'II'} = + \text{ } \%$$

Solar contribution and Supplementary heat pump 6

Select smaller value = -

$$0.5 \times \text{ } \text{ OR } 0.5 \times \text{ } = - \text{ } \%$$

Seasonal space heating energy efficiency of package 7

Seasonal space heating energy efficiency class of package

<input type="checkbox"/>	<input type="checkbox"/>	<input type="checkbox"/>	<input type="checkbox"/>	<input type="checkbox"/>	<input type="checkbox"/>	<input type="checkbox"/>	<input type="checkbox"/>	<input type="checkbox"/>	<input type="checkbox"/>
G	F	E	D	C	B	A	A ⁺	A ⁺⁺	A ⁺⁺⁺
< 30 %	≥ 30 %	≥ 34 %	≥ 36 %	≥ 75 %	≥ 82 %	≥ 90 %	≥ 98 %	≥ 125 %	≥ 150 %

Boiler and supplementary heat pump installed with low temperature heat emitters at 35°C?

From fiche of heat pump 7 + (50 x 'II') = %

The energy efficiency of the package of products provided far in this fiche may not correspond to its actual energy efficiency once installed in a building, as the efficiency is influenced by further factors such as heat loss in the distribution system and the dimensioning of the products in relation to building size and characteristics.

Parameters for filling in the package fiche.

Parameter	Victrix 12 X TT 2 ErP	Victrix 20 X TT 2 ErP
'I'	93	93
'II'	*	*
'III'	2,22	1,27
'IV'	0,87	0,49

* to be established by means of table 5 of Regulation 811/2013 in case of "assembly" including a heat pump to integrate the boiler. In this case the boiler must be considered as the main appliance of the assembly.

3-17

Room heating system package fiche.

Seasonal space heating energy efficiency of boiler 1 %

Temperature control From fiche of temperature control 2 %

Class I = 1 %, Class II = 2 %,
Class III = 1.5 %, Class IV = 2 %,
Class V = 3 %, Class VI = 4 %,
Class VII = 3.5 %, Class VIII = 5 %

Supplementary boiler From fiche of boiler 3 %

Seasonal space heating energy efficiency (in %)

$(\text{ } - \text{ }) \times 0.1 = \pm \text{ } \%$

Solar contribution From fiche of solar device 4 %

Collector size (in m²) Tank volume (in m³) Collector efficiency (in %)

Tank rating
A* = 0.95, A = 0.91,
B = 0.86, C = 0.83,
D-G = 0.81

$(\text{ } \times \text{ } + \text{ } \times \text{ }) \times (0.9 \times (\text{ } / 100) \times \text{ } = + \text{ } \%$

Supplementary heat pump From fiche of heat pump 5 %

Seasonal space heating energy efficiency (in %)

$(\text{ } - \text{ }) \times \text{ } = + \text{ } \%$

Solar contribution and Supplementary heat pump 6 %

Select smaller value $0.5 \times \text{ } \text{ OR } 0.5 \times \text{ } = - \text{ } \%$

Seasonal space heating energy efficiency of package 7 %

Seasonal space heating energy efficiency class of package

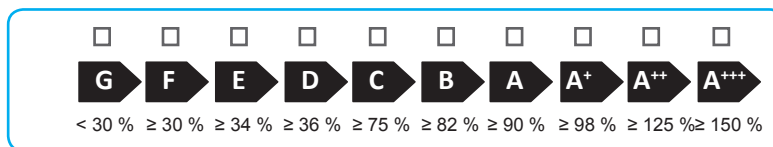

Boiler and supplementary heat pump installed with low temperature heat emitters at 35°C?

From fiche of heat pump 7 %

$\text{ } + (50 \times \text{ }) = \text{ } \%$

The energy efficiency of the package of products provided far in this fiche may not correspond to its actual energy efficiency once installed in a building, as the efficiency is influenced by further factors such as heat loss in the distribution system and the dimensioning of the products in relation to building size and characteristics.

3-18



Facsimile for filling in domestic hot water production system package fiche.

Water heating energy efficiency of combination heater

¹
 %

Declared load profile:

Solar contribution

From fiche of solar device

Auxiliary electricity

$$(1,1 \times '1' - 10\%) \times '11' - '111' - '1' = + \text{} \%$$

Water heating energy efficiency of package under average climate

³
 %

Water heating energy efficiency class of package under average climate

	<input type="checkbox"/>	<input type="checkbox"/>	<input type="checkbox"/>	<input type="checkbox"/>	<input type="checkbox"/>	<input type="checkbox"/>	<input type="checkbox"/>	<input type="checkbox"/>	<input type="checkbox"/>	<input type="checkbox"/>
	G	F	E	D	C	B	A	A⁺	A⁺⁺	A⁺⁺⁺
<input type="checkbox"/> M	< 27 %	≥ 27 %	≥ 30 %	≥ 33 %	≥ 36 %	≥ 39 %	≥ 65 %	≥ 100 %	≥ 130 %	≥ 163 %
<input type="checkbox"/> L	< 27 %	≥ 27 %	≥ 30 %	≥ 34 %	≥ 37 %	≥ 50 %	≥ 75 %	≥ 115 %	≥ 150 %	≥ 188 %
<input type="checkbox"/> XL	< 27 %	≥ 27 %	≥ 30 %	≥ 35 %	≥ 38 %	≥ 55 %	≥ 80 %	≥ 123 %	≥ 160 %	≥ 200 %
<input type="checkbox"/> XXL	< 28 %	≥ 28 %	≥ 32 %	≥ 36 %	≥ 40 %	≥ 60 %	≥ 85 %	≥ 131 %	≥ 170 %	≥ 213 %

Water heating energy efficiency under colder and warmer climate conditions

Colder: ³ - 0.2 x ² = %

Warmer: ³ + 0.4 x ² = %

The energy efficiency of the package of products provided far in this fiche may not correspond to its actual energy efficiency once installed in a building, as the efficiency is influenced by further factors such as heat loss in the distribution system and the dimensioning of the products in relation to building size and characteristics.

Parameters for filling in DHW package package fiche.

Parameter	Victrix 12 X TT 2 ErP	Victrix 20 X TT 2 ErP
I'	--	--
II'	*	*
III'	*	*

* to be determined according to Regulation 811/2013 and transient calculation methods as per Notice of the European Community no. 207/2014.

3-20

Domestic hot water production system package fiche.

Water heating energy efficiency of combination heater

%

Declared load profile:

Solar contribution
From fiche of solar device

Auxiliary electricity

$(1,1 \times \text{---} - 10\%) \times \text{---} - \text{---} \text{---} =$

%

Water heating energy efficiency of package under average climate

%

Water heating energy efficiency class of package under average climate

	G	F	E	D	C	B	A	A ⁺	A ⁺⁺	A ⁺⁺⁺
<input type="checkbox"/> M	< 27 %	≥ 27 %	≥ 30 %	≥ 33 %	≥ 36 %	≥ 39 %	≥ 65 %	≥ 100 %	≥ 130 %	≥ 163 %
<input type="checkbox"/> L	< 27 %	≥ 27 %	≥ 30 %	≥ 34 %	≥ 37 %	≥ 50 %	≥ 75 %	≥ 115 %	≥ 150 %	≥ 188 %
<input type="checkbox"/> XL	< 27 %	≥ 27 %	≥ 30 %	≥ 35 %	≥ 38 %	≥ 55 %	≥ 80 %	≥ 123 %	≥ 160 %	≥ 200 %
<input type="checkbox"/> XXL	< 28 %	≥ 28 %	≥ 32 %	≥ 36 %	≥ 40 %	≥ 60 %	≥ 85 %	≥ 131 %	≥ 170 %	≥ 213 %

Water heating energy efficiency under colder and warmer climate conditions

Colder: $\text{---} - 0.2 \times \text{---} = \text{---} \%$

Warmer: $\text{---} + 0.4 \times \text{---} = \text{---} \%$

The energy efficiency of the package of products provided far in this fiche may not correspond to its actual energy efficiency once installed in a building, as the efficiency is influenced by further factors such as heat loss in the distribution system and the dimensioning of the products in relation to building size and characteristics.

3-21



immergas.com

Immergas S.p.A.
42041 Brescello (RE) - Italy
Tel. 0522.689011
Fax 0522.680617

Certified company ISO 9001

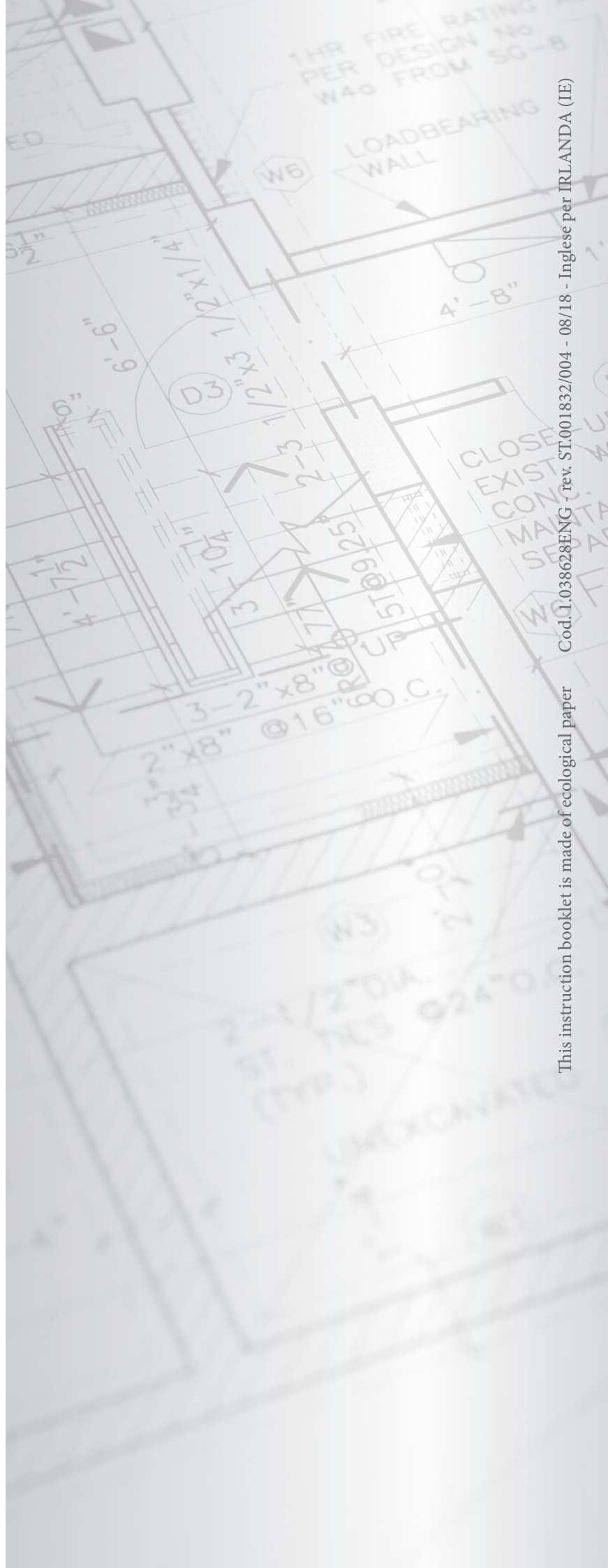

This instruction booklet is made of ecological paper

Cod. I.038628ENG - rev. ST.001832/004 - 08/18 - Inglese per IRLANDA (IE)

STD.002571/004