

TECHNICAL SHEETS

CONDENSING



VICTRIX MAIOR TT ErP
VICTRIX MAIOR X TT ErP

Wall-hung compact
condensing boilers



VICTRIX MAIOR TT ErP



VICTRIX MAIOR TT ErP is the range of condensing combi wall-hung boilers available in 2 versions, with 28 and 35 kW powers.

It is characterised by the innovative **primary heat exchanger that ensures high flow rates and heads** on the heating circuit, also replacing oil systems, with **low clogging risk**, and for the presence of an **“advanced” P.C.B. with electronic gas change** (without nozzle replacement) and **control system of the self-adapting combustion**.

Also note the **wide modulation range** (from 12 to 100% for 28 kW model and from 10 to 100% for 35 kW model) with high yields even with low energy absorption and **performance on DHW** equal to *******, the maximum achievable thanks to the electronic water flow rate regulator.

The boiler also has an easy to use and **advanced user interface** with adjustment knobs, selection buttons and LCD display.

Thanks to the condensation technology, it has a high yield and ensures particularly reduced polluting emissions (class 6 of NO_x).

The VICTRIX MAIOR TT ErP range models are also **designed for outdoor operation** in partially protected places and are equipped with a standard antifreeze system that protects them to a temperature of -5°C (with optional it up to -15°C).

1

FEATURES VICTRIX MAIOR 28-35 TT 1 ErP

Pre-mixed wall-mounted condensing boiler for central heating and production of DHW, with sealed chamber and fan-assisted with nominal heat output of 24 kW in CH mode (28 kW in DHW) or 34.2 kW, Eco friendly with high efficiency and forced circulation.

By varying the type of installation the classification of the boiler also varies.

OUTDOOR INSTALLATION (in partially protected area):

Appliance with direct air intake- if installed using a flue terminal and the (optional) mandatory top cover kit, also eliminating a sealed chamber intake cap.

Appliance type C₁₃ / C₃₃ / C₄₃ / C₅₃ / C₆₃ / C₈₃ / C₉₃ - if installed using the vertical or horizontal concentric kits or Ø 80/80 separator kit, without using the top cover kit.

INDOOR INSTALLATION:

Appliance type C₁₃ / C₃₃ / C₄₃ / C₅₃ / C₆₃ / C₈₃ / C₉₃ - if installed using the vertical or horizontal concentric kits or the Ø 80/80 separator kit.

Appliance type B₂₃ - if installed using a flue kit and the (optional) mandatory top cover kit, also eliminating a sealed chamber intake caps.

The boiler is made up of:

- total pre-mixing combustion system with inverted flame metal fibre burner, complete with only one ignition electrode and ionisation control;
- electronic gas valve and control system of the self-adapting combustion that allows for electronic gas change through parameter setting from the board, so there is only one product

code (ref. methane);

- gas/water primary heat exchanger made of special Aluminium-Silica-Magnesium alloy;
- fan for flue evacuation with electronically variable speed;
- circuit for disposal of condensate including trap and flexible drain hose;
- secondary water/water exchanger for the production of domestic hot water realised in stainless steel with 18 plates;
- hydraulic group composed of electric 3-way valve, low power consumption modulating circulation pump with automatic speed control on the basis of the ΔT measured between system flow and return (factory set 15°C) with incorporated air separator, adjustable and excludable by-pass, primary circuit absolute pressure switch, system drain fitting, system filling cock;
- primary circuit safety valve at 3 bar; discharge of the safety valve is conveyed together with the condensate discharge;
- DHW flow regulator including DHW inlet probe, DHW flow meter for circulating flow control;
- 10 nominal litre (effective 7.1) expansion vessel system with diaphragm with factory-set pressure at 1.0 bar and manometer;
- flue control probe and heat exchanger safety flow probe;
- central heating system temperature adjustment selector, DHW temperature adjustment selector, function button (Off, Stand-by, On), Summer, Winter button, Reset button, information button, digital display;
- control panel with visible controls and microprocessor driven

VICTRIX MAIOR TT ErP

P.C.B. with continuous flame modulation via 2 sensors for central heating (flow and return) and 2 sensors for domestic hot water with P.I.D. control and modulation range:

- VICTRIX MAIOR 28 TT 1 ErP from 2.8 to 24.0 kW (28.0 kW in DHW);
- VICTRIX MAIOR 35 TT 1 ErP from 3.5 to 34.2 kW
- CH temperature range selection from min. = 20-50C to max. = set min. +5°C -85°C (standard setting 25-85°C);
- electronic ignition with ionisation control;
- ignition delay device in CH phase, anti-freeze protection system (to -5°C), pump anti-block device function, post-ventilation function, chimney sweep function and pump functioning mode selection;
- solar delay timer function for solar system coupling;
- BOOST function (can be activated by pressing the INFO and RESET keys), which pre-heats the plate heat exchanger in a timed manner, to reduce stand-by times for the supply of domestic hot water;
- self-diagnosis system with digital display of the temperature, functioning mode and error codes by means of the back-lit display;
- predisposition for connection to the CAR^{V2}, CAR^{V2} WIRELESS, Chrono-thermostat, External probe and control unit for area systems;
- IPX5D electric protection index;
- possibility of coupling to the system for ducting of existing flues Ø 50 mm, Ø 60 mm and Ø 80 mm;
- connection kit with depth-adjustable connections on the hydraulic attachments and gas and domestic cold water cut-off cocks;
- set-up for management via the new DOMINUS App which allows the user to program and display the main operating parameters from smartphone and tablet. Required DOMINUS interface board kit (optional).

Supplied complete with sample points for combustion analysis, lower aesthetic cover.

Category II_{2H3P} appliance, functions with a natural gas, L.P.G. CE Marking.

It is available in the model:

- **VICTRIX MAIOR 28 TT 1 ErP** code **3.024882**
- **VICTRIX MAIOR 35 TT 1 ErP** code **3.024883**

N.B.: for correct installation of the boiler the Immergas "Green Range" air intake/flue exhaust kit must be used.

VICTRIX MAIOR X TT ErP



VICTRIX MAIOR X TT ErP is the wall-mounted condensing boiler for central heating only with output of 35 kW prepared for coupling to separate Immergas of 80, 120 and 200 litre storage tank units (including the UB INOX SOLAR 200 V2). It is ideal especially for homes with several bathrooms and where great amounts of water are required quickly, ensuring a considerable production of domestic hot water. Boiler and Storage Tank Unit can even be installed in different rooms, thus increasing installation flexibility.

It is characterised by the innovative **primary heat exchanger that ensures high flow rates and heads** on the heating circuit, also replacing oil systems, with **low clogging risk**, and for the presence of an **“advanced” P.C.B. with electronic gas change** (without nozzle replacement) and **control system of the self-adapting combustion**.

Also to be noted is the **wide range of modulation** (from 10 to 100%) with high performance even in presence of low energy absorption.

The boiler also has an easy to use and **advanced user interface** with adjustment knobs, selection buttons and LCD display.

Thanks to the condensation technology, it has a high yield and ensures particularly reduced polluting emissions (class 6 of NO_x).

VICTRIX MAIOR X TT ErP is **designed for outdoor operation** in partially protected places and is equipped with a standard antifreeze system that protects them to a temperature of -5°C (with optional it up to -15°C).

2

FEATURES VICTRIX MAIOR 35 X TT 1 ErP

Pre-mixed wall-hung condensing boiler with sealed chamber and fan-assisted draft with nominal heat output of 34.2 kW Eco friendly with high-efficiency and forced circulation for central heating, prepared for coupling to separate storage tank units for the production of domestic hot water.

By varying the type of installation the classification of the boiler also varies.

OUTDOOR INSTALLATION (in partially protected area):

Appliance with direct air intake- if installed using a flue terminal and the (optional) mandatory top cover kit, also eliminating a sealed chamber intake cap.

Appliance type $C_{13}/C_{33}/C_{43}/C_{53}/C_{63}/C_{83}/C_{93}$ - if installed using the vertical or horizontal concentric kits or $\text{Ø } 80/80$ separator kit, without using the top cover kit.

INDOOR INSTALLATION:

Appliance type $C_{13}/C_{33}/C_{43}/C_{53}/C_{63}/C_{83}/C_{93}$ - if installed using the vertical or horizontal concentric kits or the $\text{Ø } 80/80$ separator kit.

Appliance type B_{23} - if installed using a flue kit and the (optional) mandatory top cover kit, also eliminating a sealed chamber intake caps.

The boiler is made up of:

- total pre-mixing combustion system with inverted flame metal fibre burner, complete with only one ignition electrode and ionisation control;

- electronic gas valve and control system of the self-adapting combustion that allows for electronic gas change through parameter setting from the board, so there is only one product code (ref. methane);
- gas/water primary heat exchanger made of special Aluminium-Silica-Magnesium alloy;
- fan for flue evacuation with electronically variable speed;
- circuit for disposal of condensate including trap and flexible drain hose;
- hydraulic group composed of electric 3-way valve, low power consumption modulating circulation pump with automatic speed control on the basis of the ΔT measured between system flow and return (factory set 15°C) with incorporated air separator, adjustable and excludable by-pass, primary circuit absolute pressure switch, system drain fitting, system filling cock;
- primary circuit safety valve at 3 bar; discharge of the safety valve is conveyed together with the condensate discharge;
- 10 nominal litre (effective 7.1) expansion vessel system with diaphragm with factory-set pressure at 1.0 bar and manometer;
- flue control probe and heat exchanger safety flow probe;
- central heating system temperature adjustment selector, DHW temperature adjustment selector, function button (Off, Stand-by, On), Summer, Winter button, Reset button, information button, digital display;

VICTRIX MAIOR X TT ErP

- control panel with visible controls and microprocessor driven P.C.B. with continuous flame modulation via 2 sensors for central heating (flow and return) with P.I.D. control and modulation range: from 3.5 to 34.2 kW;
- CH temperature range selection from min. = 20-50C to max. = set min. +5°C -85°C (standard setting 25-85°C);
- electronic ignition with ionisation control;
- ignition delay device in CH phase, anti-freeze protection system (to -5°C), pump anti-block device function, post-ventilation function, chimney sweep function and pump functioning mode selection;
- DHW thermostat function for coupling to solar systems;
- self-diagnosis system with digital display of the temperature, functioning mode and error codes by means of the back-lit display;
- predisposition for connection to the CAR^{V2}, CAR^{V2} WIRELESS, Chrono-thermostat, External probe and control unit for area systems;
- IPX5D electric protection index;
- possibility of coupling to the system for ducting of existing flues Ø 50 mm, Ø 60 mm and Ø 80 mm;
- connection kit with depth-adjustable connections on the hydraulic attachments and gas and domestic cold water cut-off cocks;
- set-up for management via the new DOMINUS App which allows the user to program and display the main operating parameters from smartphone and tablet. Required DOMINUS interface board kit (optional).

Supplied complete with sample points for combustion analysis, lower aesthetic cover.

Category II_{2H3P} appliance, functions with a natural gas, L.P.G. CE Marking.

It is available in the model:

- **VICTRIX MAIOR 35 X TT 1 ErP** **code**
3.024884

N.B.: for correct installation of the boiler the Immergas "Green Range" air intake/flue exhaust kit must be used.

3

STORAGE TANK UNIT



3.1

FEATURES

The Storage tank unit consisting of:

- 80 litre, 120 litre or 200 litre storage tank (based on the models) made of stainless steel, with upper inspection flange;
- water/water heat exchanger wound in double concentric spiral (2 in the 120 litre and 200 litre model) made of stainless steel and removable;
- 8 bar safety valve;
- diaphragm DHW expansion vessel of 4 litres (Storage tank unit 80), of 5 litres (Storage tank unit 120) and of 8 litres (Storage tank unit 200 and SOLAR 200) with 2.5 bar preload;
- domestic hot water temperature control probe;
- storage tank draining valve;
- on the control panel there is a thermometer (UB INOX 80 V2, UB INOX 120 V2 and UB INOX 200 V2 versions) or a solar water pressure gauge (UB INOX SOLAR 200 V2);
- insulation in ecological self-extinguishing polyester with a 5 cm thickness.

Furthermore, the UB INOX SOLAR 200 V2 integrates the following components inside the casing:

- single circulation unit with low electrical consumption of 1-6 l/min;
- 18 litre solar expansion vessel;
- thermostatic mixing valve with 3/4" connections;
- solar control unit integrated in storage tank control panel with relative temperature probes;
- solar circuit connection pipes for heating the lower coil via a solar heating system (optional for UB INOX 120 V2 and UB INOX 200 V2);
- 6 bar solar circuit safety valve.

It is available in the model:

- | | |
|-------------------------------|----------------------|
| • UB INOX 80 V2 | code 3.027817 |
| • UB INOX 120 V2 | code 3.027818 |
| • UB INOX 200 V2 | code 3.027819 |
| • UB INOX SOLAR 200 V2 | code 3.027820 |

VICTRIX MAIOR TT ErP

4 MAIN DIMENSIONS VICTRIX MAIOR TT ErP

Model	Height mm	Width mm	Depth mm	Ø intake/exhaust mm
VICTRIX MAIOR TT ErP	748	440	280	100/60 - 125/80 - 80/80

4.1 CONNECTIONS

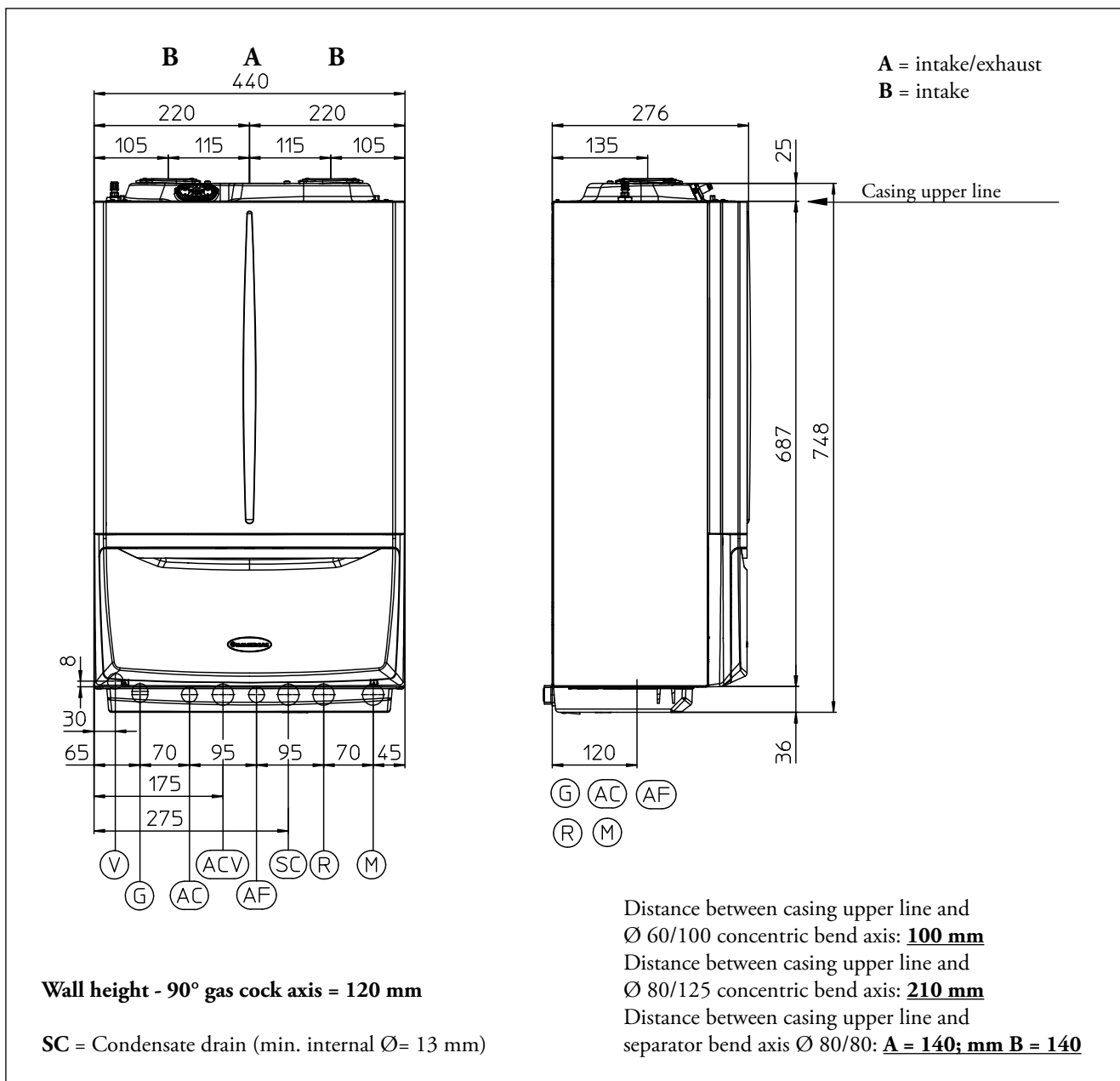

Model	Flow M	Return R	Hot Intlet AC	Cold Input AF	Gas G	Expansion vessel Litres
VICTRIX MAIOR TT	3/4"	3/4"	1/2"	1/2"	3/4"	10 (real 7.1)

VICTRIX MAIOR X TT ErP

5 MAIN DIMENSIONS VICTRIX MAIOR X TT ERP

Model	Height mm	Width mm	Depth mm	Ø intake/exhaust mm
VICTRIX MAIOR X TT ErP	748	440	280	100/60 - 125/80 - 80/80

5.1 CONNECTIONS

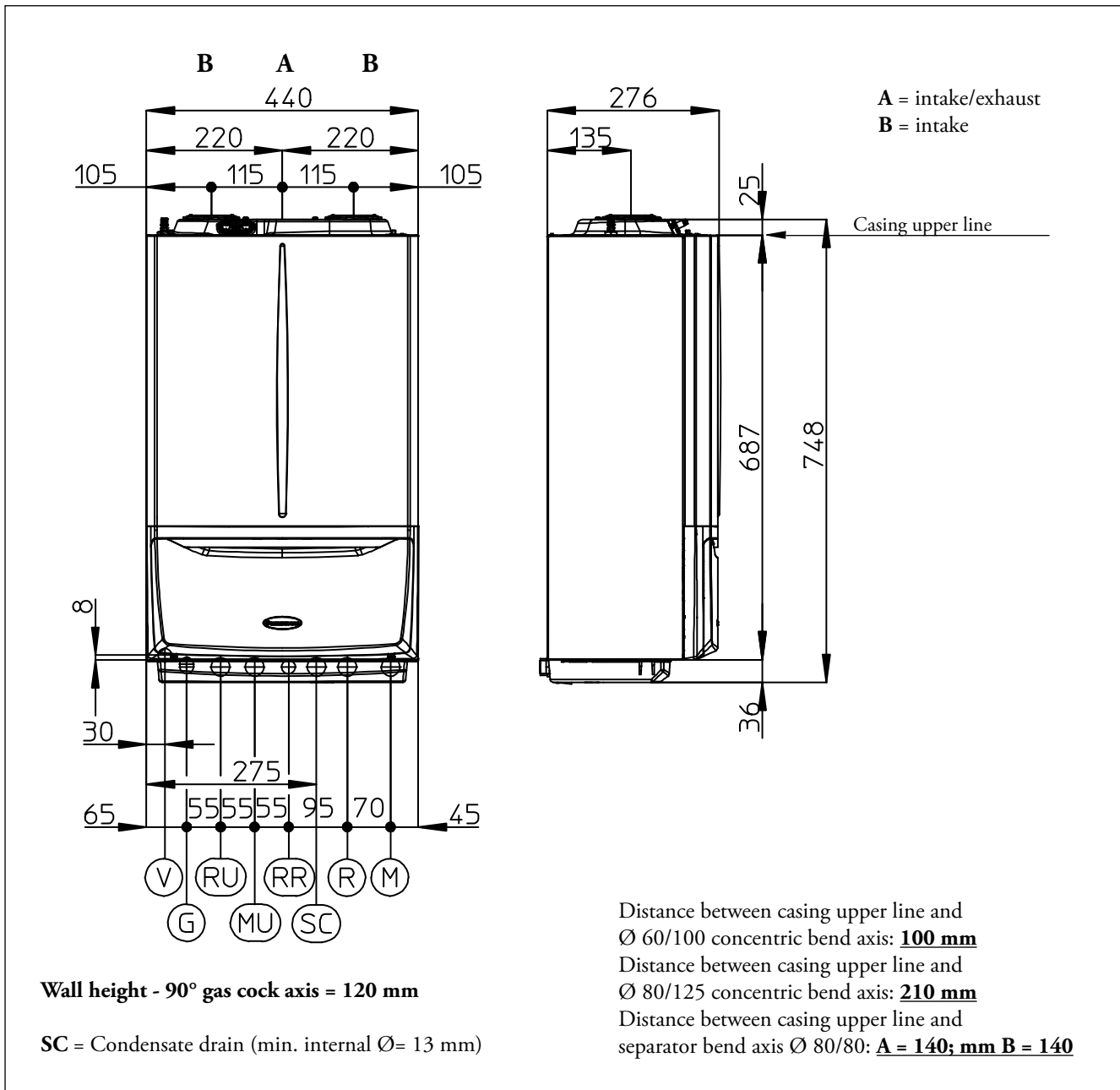

Model	Flow M	Return R	Flow S.T. MU	Return S.T. RU	Filling RR System	Gas G	Expansion vessel Litres
VICTRIX MAIOR X TT ErP	3/4"	3/4"	3/4"	3/4"	1/2"	3/4"	10 (real 7.1)

VICTRIX MAIOR X TT ErP

6 STORAGE TANK UNIT MAIN DIMENSIONS (X Model)

	UB INOX 80 V2	UB INOX 120 V2	UB INOX 200 V2	UB INOX SOLAR 200 V2
Height mm	850	850	1250	1250
Width mm	550	650	650	650
Depth mm	550	650	650	750

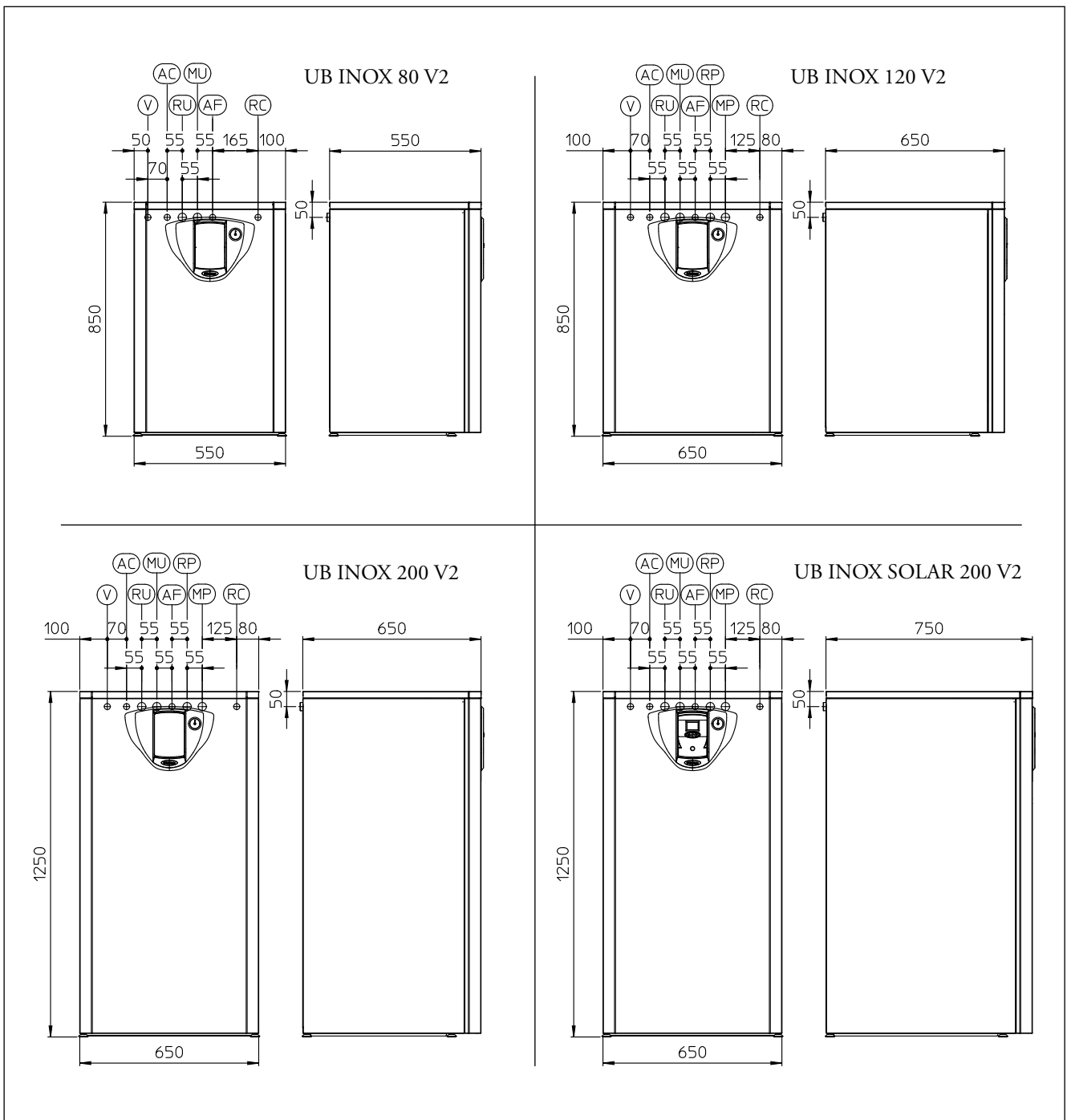

Storage tank Flow	Storage tank return	Cold Inlet	Hot Outlet	Recirculation	Panels Flow	Panels Return
MU	RU	AF	AC	RC	MP	RP
3/4"	3/4"	3/4"	3/4"	1/2"	3/4"	3/4"

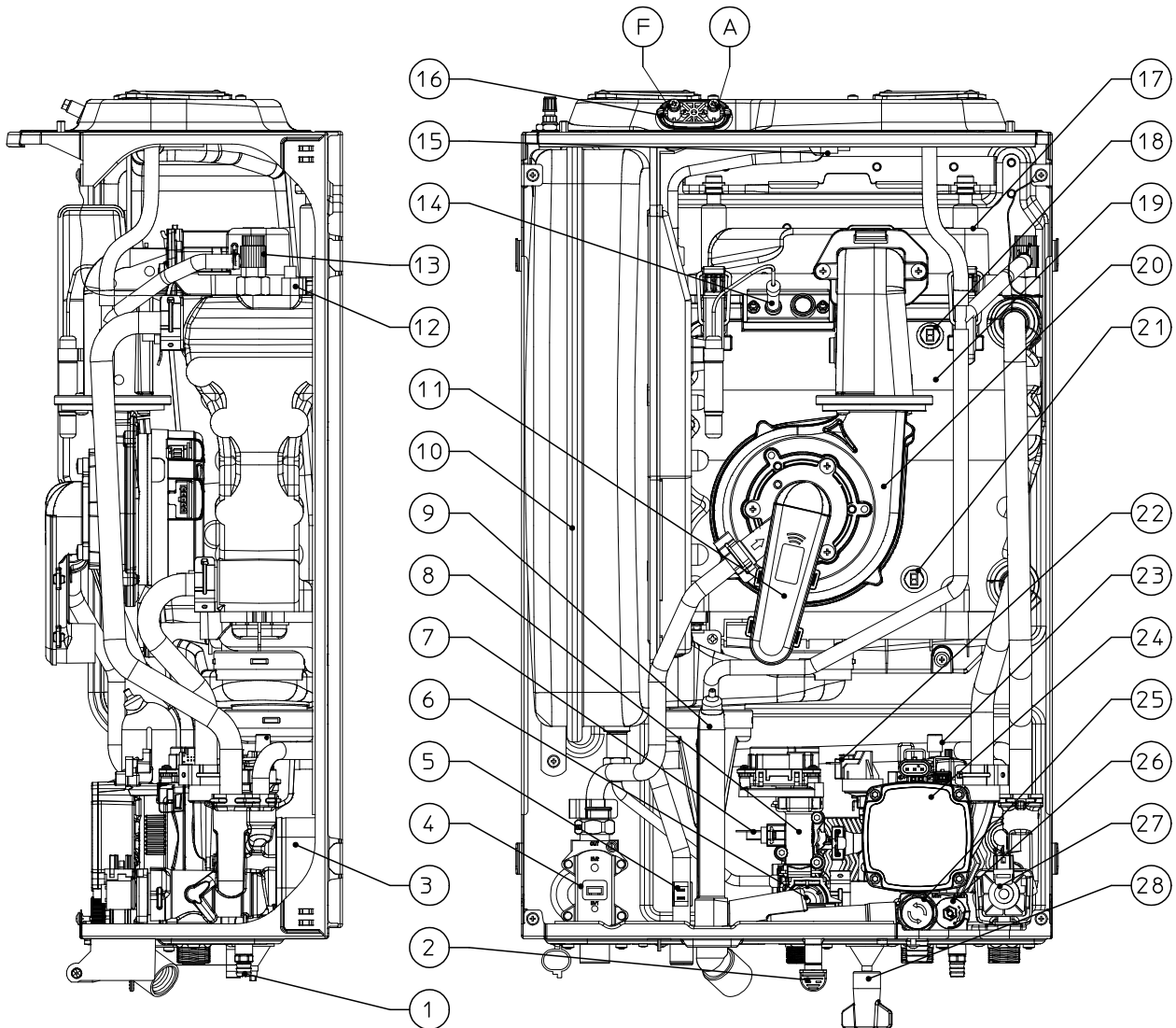

KEY:

- | | |
|---|--|
| <ul style="list-style-type: none"> 1 - System draining valve 2 - 3-bar safety valve drain fitting signal 3 - DHW heat exchanger 4 - Gas valve 5 - DHW probe 6 - Domestic hot water flow meter 7 - DHW inlet probe 8 - D.h.w. flow-rate regulator 9 - Condensate drain trap 10 - System expansion vessel 11 - Air / gas mixer 12 - Flow probe 13 - Manual air vent valve 14 - Ignition/detection electrode | <ul style="list-style-type: none"> 15 - Flue probe 16 - Sample points (air A) - (flue gases F) 17 - Burner Cover 18 - Safety flow probe 19 - Condensation module 20 - Fan 21 - Return probe 22 - System pressure switch 23 - Air vent valve 24 - Boiler pump 25 - 3 bar safety valve 26 - By-pass 27 - 3-way valve (motorised) 28 - System filling valve |
|---|--|

VICTRIX MAIOR X TT ErP

8

MAIN COMPONENTS VICTRIX MAIOR X TT ErP

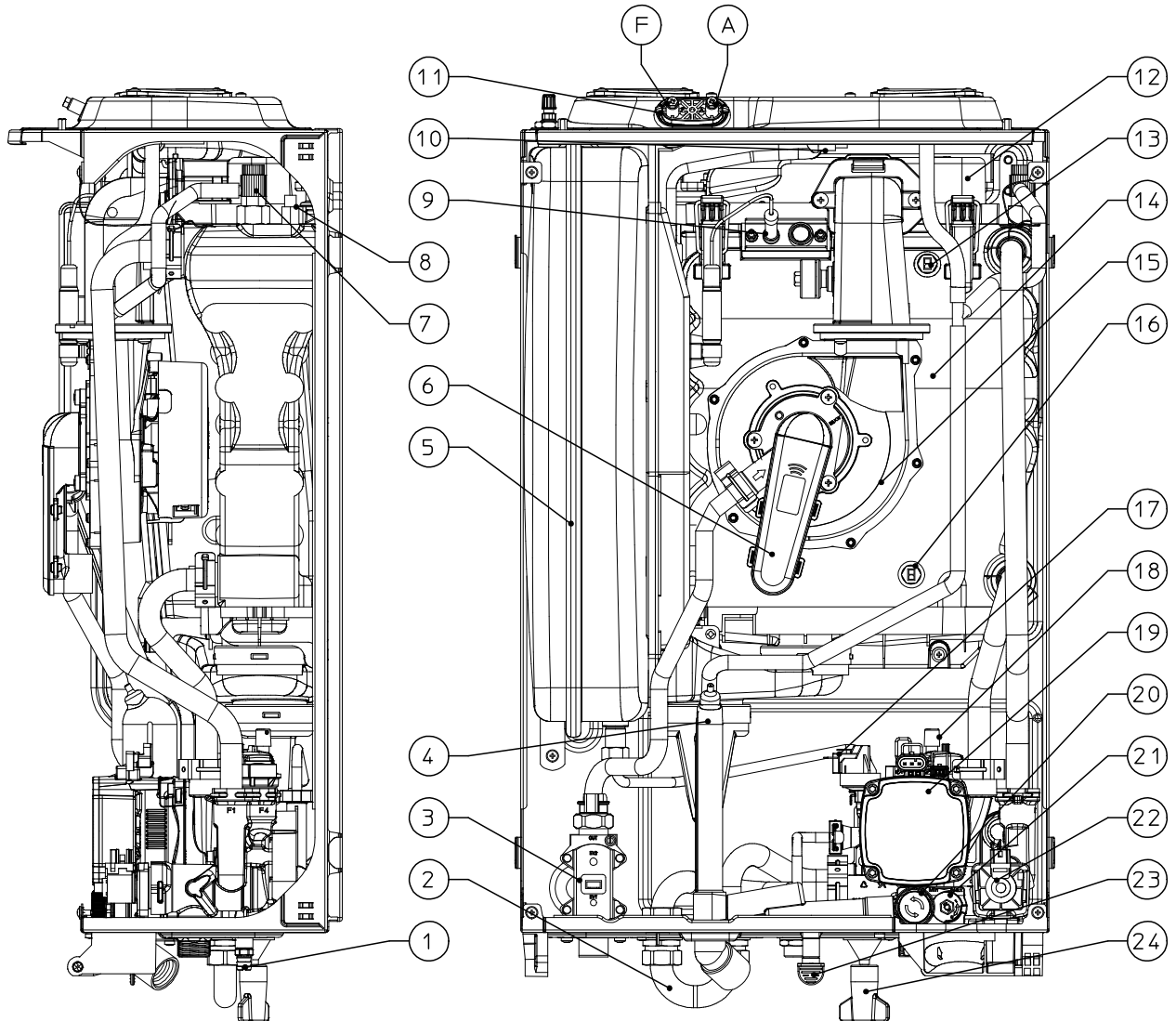

KEY:

- | | |
|---|--|
| 1 - System draining valve | 14 - Condensation module |
| 2 - Storage tank return flow by-pass | 15 - Fan |
| 3 - Gas valve | 16 - Return probe |
| 4 - Condensate drain trap | 17 - System pressure switch |
| 5 - System expansion vessel | 18 - Air vent valve |
| 6 - Air / gas mixer | 19 - Boiler pump |
| 7 - Manual air vent valve | 20 - 3 bar safety valve |
| 8 - Flow probe | 21 - By-pass |
| 9 - Ignition/detection electrode | 22 - 3-way valve (motorised) |
| 10 - Flue probe | 23 - 3-bar safety valve drain fitting signal |
| 11 - Sample points (air A) - (flue gases F) | 24 - System filling valve |
| 12 - Burner Cover | |
| 13 - Safety flow probe | |

STORAGE TANK UNIT MAIN COMPONENTS (X Model)

UB INOX 80 V2

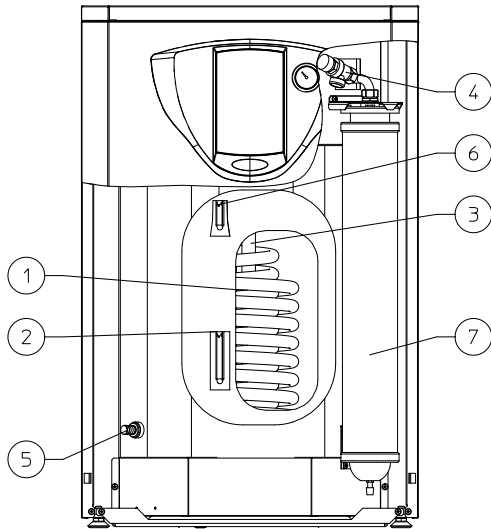

UB INOX 120 V2

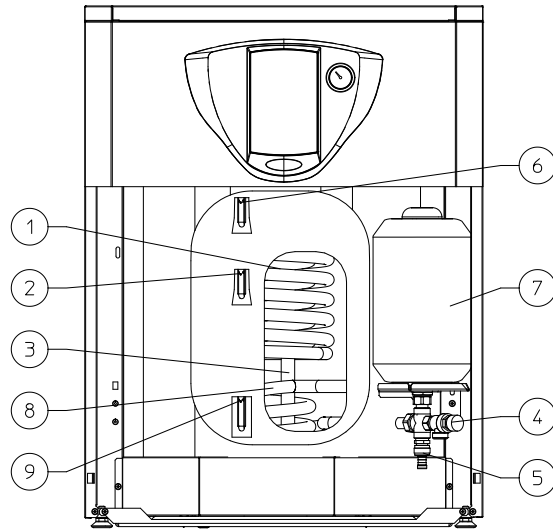

UB INOX 200 V2

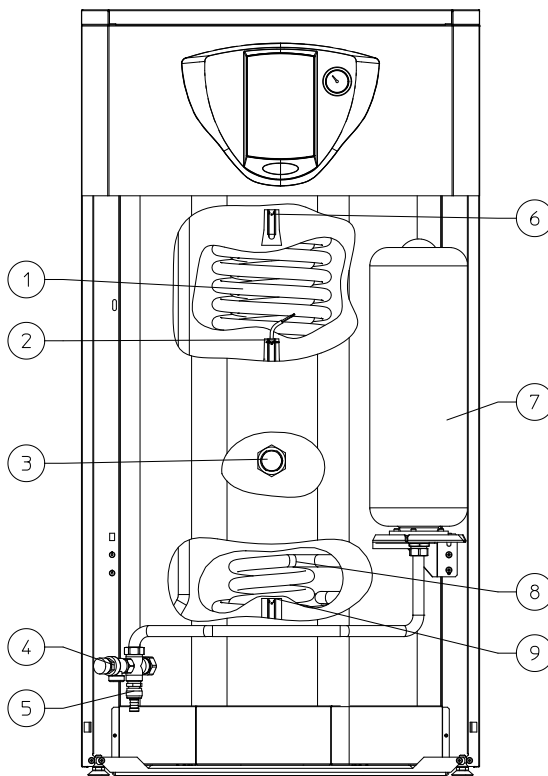

KEY:

- 1 - Stainless steel coil for storage tank
- 2 - DHW probe
- 3 - Magnesium anode
- 4 - 8 bar safety valve
- 5 - Storage tank draining valve
- 6 - Thermometer probe
- 7 - DHW expansion vessel
- 8 - Coil that can be coupled to solar panels
- 9 - Solar panels probe (Optional)

VICTRIX MAIOR X TT ErP

10

UB INOX SOLAR 200 V2 STORAGE TANK UNIT MAIN COMPONENTS

UB INOX SOLAR 200 V2

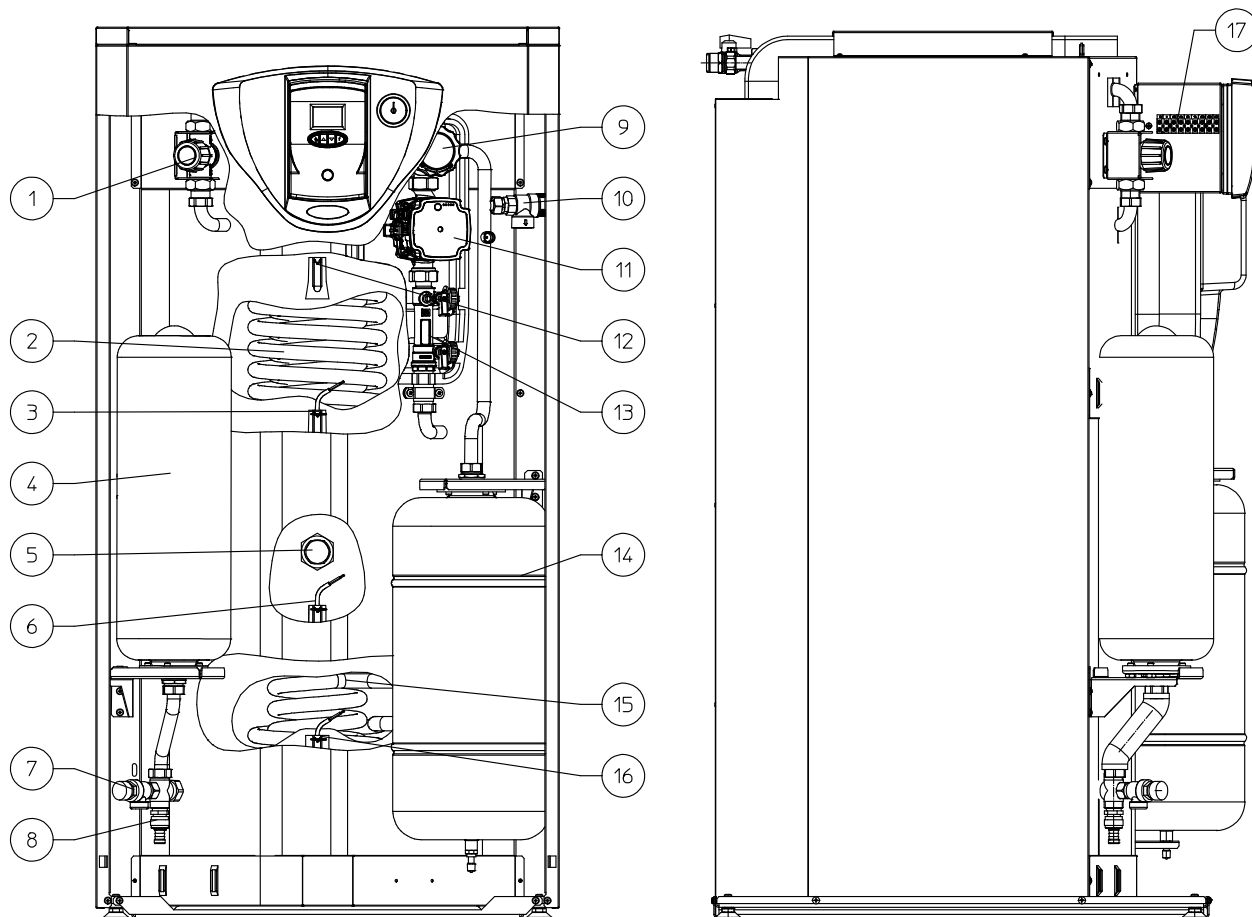

KEY:

- | | |
|---|---|
| 1 - DHW circuit mixing valve | 10 - 6 bar safety valve |
| 2 - Stainless steel coil for storage tank | 11 - Solar circulator pump |
| 3 - DHW probe | 12 - Thermometer probe |
| 4 - DHW expansion vessel | 13 - Flow meter |
| 5 - Magnesium anode | 14 - Solar expansion vessel |
| 6 - Domestic hot water unabling probe | 15 - Stainless steel coil that can be coupled to solar panels |
| 7 - 8 bar safety valve | 16 - Solar panels probe |
| 8 - Storage tank draining valve | 17 - Storage tank unit electric connections terminal board |
| 9 - Shut-off valve with thermometer | |

11 GRUNDFOS UPM 3 15-70 PUMP HEAD FLOW RATE DIAGRAMS

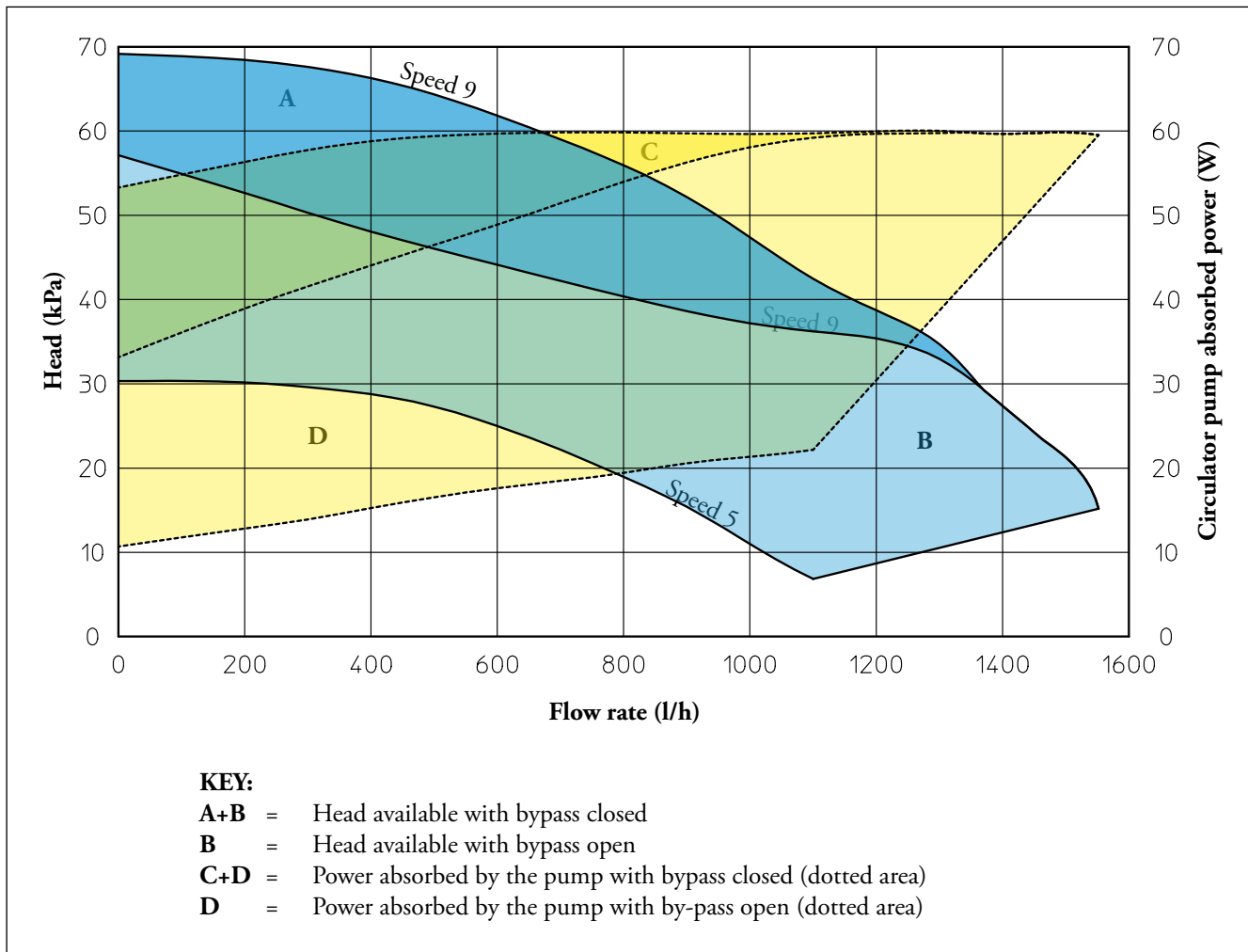

11.1 SETTINGS AND PUMP SETTINGS

The “VICTRIX MAIOR TT ErP” and “VICTRIX MAIOR X TT ErP” boilers are supplied with a variable speed pump. During central heating mode, the Auto and Fixed operating modes are available.

• **Proportional head:** the automatic circulator pump speed and proportional head: The automatic circulator pump speed varies according to the power emitted by the burner; the greater the power, the greater the speed. Moreover, within the parameter, one can also adjust the circulator pump operating range by setting the maximum speed “A3” parameter (adjustable from 5 to 9) and the “A4” minimum speed parameter (adjustable from 5 to the max. set speed). Thanks to this function, the electric power consumption of the circulator pump is reduced further: the pump absorption decreases according to the pressure level and flow rate. With this setting, the pump guarantees optimal performance in most heating systems, thereby being particularly suitable in single-pipe and two-pipe installations. Any noise originating from the water flow in the pipes, valves and radiators is eliminated by reducing the head. Optimal

conditions for thermal comfort and acoustic well-being.

- **ΔT Constant (ΔT = 5 ÷ 25 K):** the pump speed varies to maintain the ΔT constant between the system flow and return according to set value K (ΔT = 15 Default).
- **Fixed (5 ÷ 9):** by setting parameters “A3” and “A4” at the same value, the pump operates at constant speed. With these settings, the circulator pump is suitable for all floor systems where all the circuits must be balanced for the same pressure drop.

N.B.: for the boiler to work properly, it is not allowed to drop below the minimum value indicated above (speed 5).

In domestic hot water mode, the circulator pump always runs at full speed.

VICTRIX MAIOR X TT ErP

12 STORAGE TANKS HYDRAULIC LOSSES

In order to guarantee sufficient DHW flow rate, it is important to consider the resistance of the storage tank hydraulic circuit to be coupled to the boiler. In order to connect the storage tank unit to Immergas boilers properly, refer to the boiler instruction book.

12.1 UB INOX 80 V2

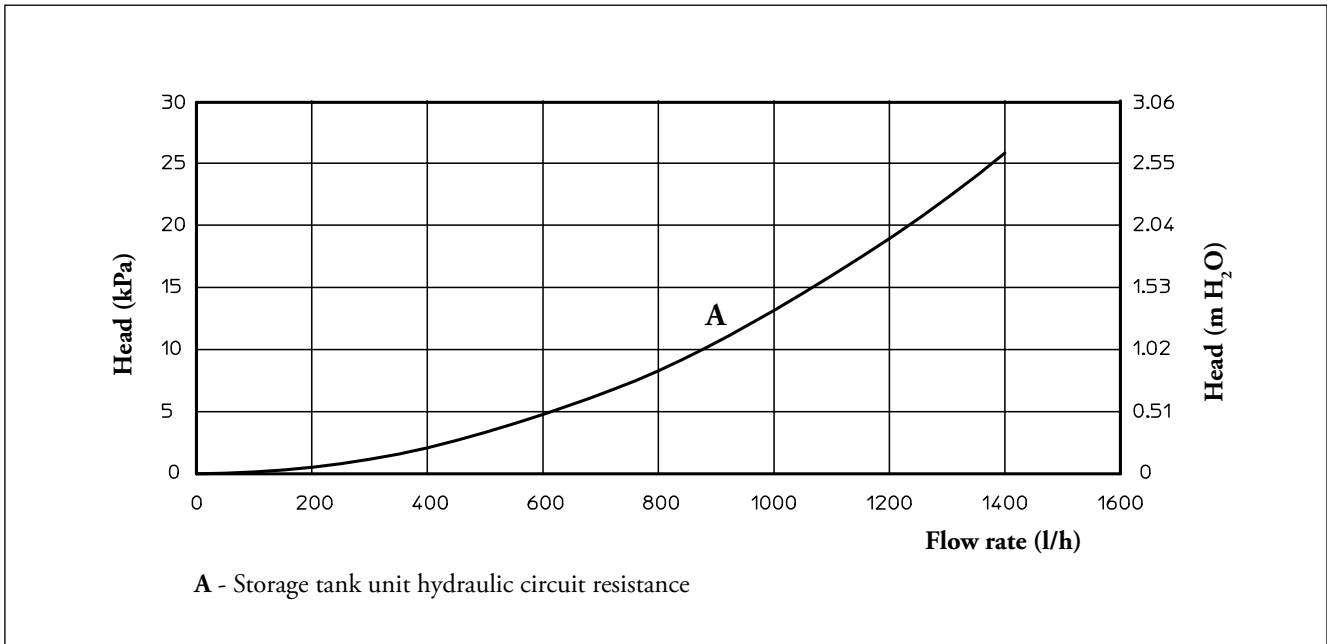

12.2 UB INOX 120 V2

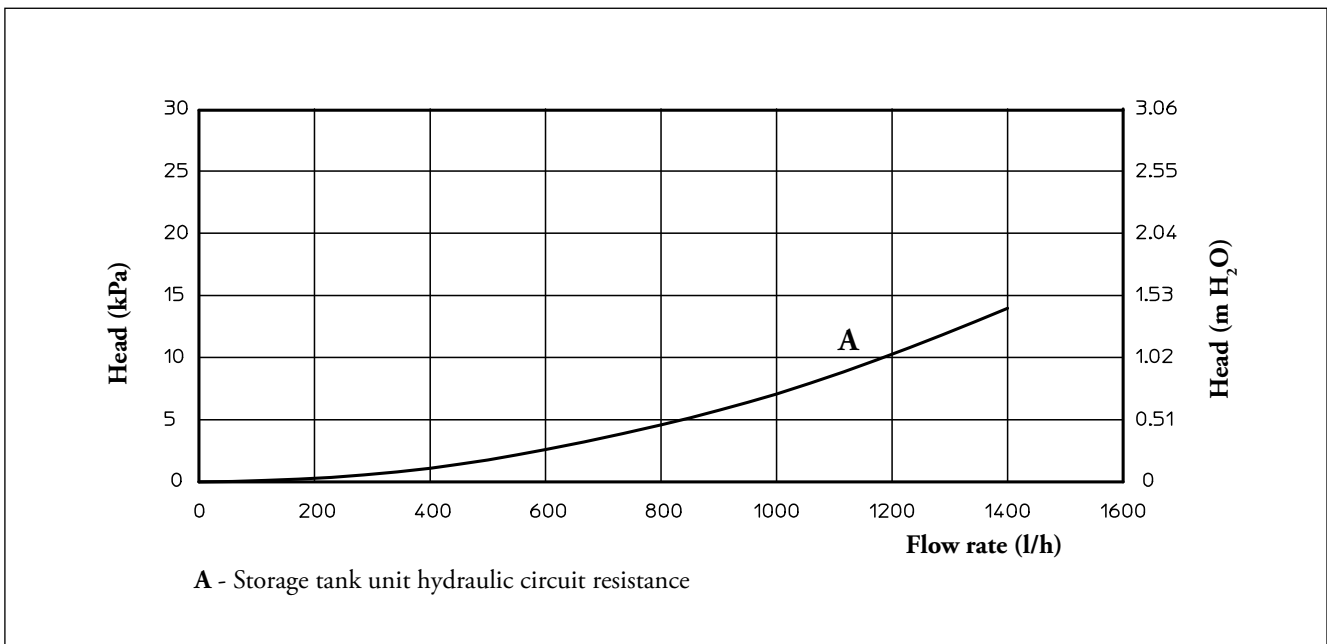

12.3

UB INOX 200 V2

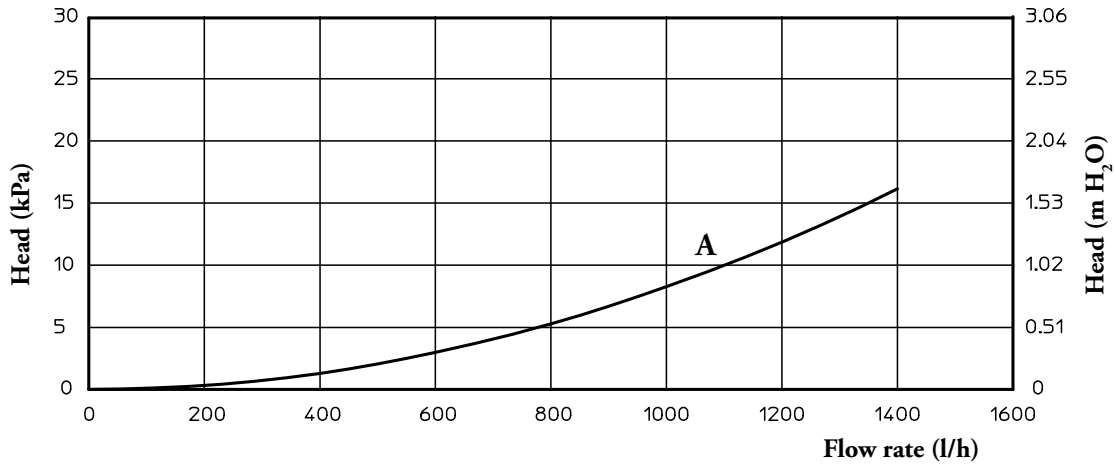

A - Storage tank unit hydraulic circuit resistance

12.4

UB INOX SOLAR 200 V2

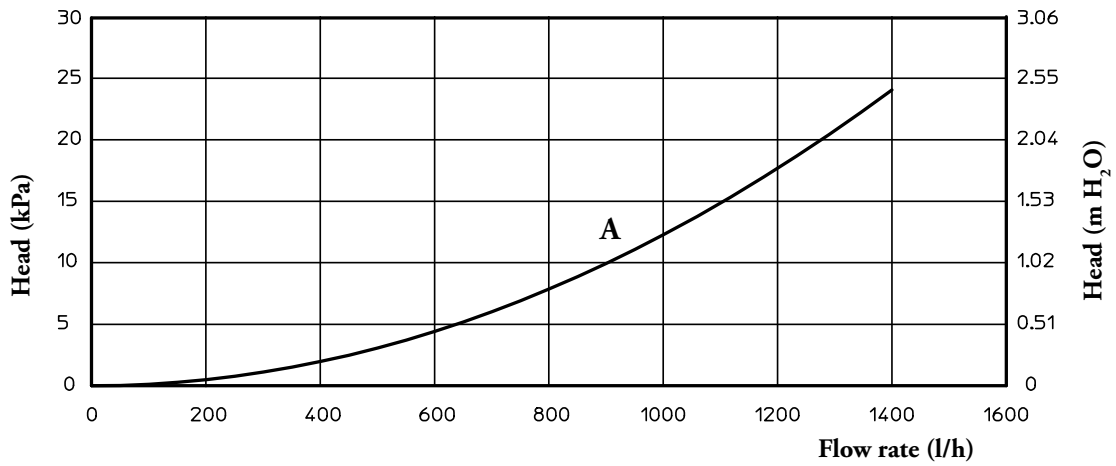

A - Storage tank unit hydraulic circuit resistance

Treating the feed water allows you to prevent problems and maintain the function and efficiency of the generator over time.

Legislative Decree 26/06/2015 requires a chemical treatment of the thermal system water, in compliance with the UNI 8065 standard, in the cases provided for by the Decree.

The parameters that influence the duration and proper operation of the heat exchanger are the water's PH, hardness, conductivity, and oxygen, together with the system's processing residues (any welding residues), any oil present and corrosion products that can, in turn, cause damage to the heat exchanger.

In order to prevent this from happening, you are recommended to:

- Before installation on new systems as well as old ones, clean the system with clean water to eliminate solid residues contained therein
- Clean the system with a chemical treatment:
 - Clean the new system with a suitable cleaning device (for example Sentinel X300, Fernox Cleaner F3 or Jenaqua 300) combined with thorough washing.
 - Clean the old system with a suitable cleaning device (for example Sentinel X400 or X800, Fernox Cleaner F3 or Jenaqua 400) combined with thorough washing.
- Check the maximum hardness and amount of filling water with reference to the following graph; if the contents and hardness of the water are below the indicated curve, no specific treatment is required; otherwise, to limit the content of calcium carbonate, you must provide for water-filling treatment.

- For filling, you are not allowed to use water softened with the use of ionic-exchange resins or distilled water.
- Should you be required to provide for water treatment, this should be carried out by completely desalinating the filling water.

As opposed to the complete softening process, desalinating the water completely not only removes hardening agents (Ca, Mg), but also eliminates all other minerals to reduce water-filling conductivity up to 10 microsiemens/cm.

Given its low conductivity, desalinated water does not only prevent the formation of lime scale, but also serves as protection against corrosion.

- Insert a suitable inhibitor / passivator (for example Sentinel X100, Fernox Protector F1, or Jenaqua 100); if required, also insert appropriate antifreeze (such as for example Sentinel X500, Fernox Alpha 11 or Jenaqua 500).
- Check electrical conduction of the water, which should be higher than 2000 $\mu\text{s}/\text{cm}$ in the case of treated water and lower than 600 $\mu\text{s}/\text{cm}$ in the case of non-treated water.
- To prevent corrosion, the water system's PH should be between 6.5 and 8.5.
- Check the maximum content of chlorides, which should be less than 250 mg/l.

N.B.: for quantities and methods of use of water-treatment products, refer to the instructions provided by their manufacturer.

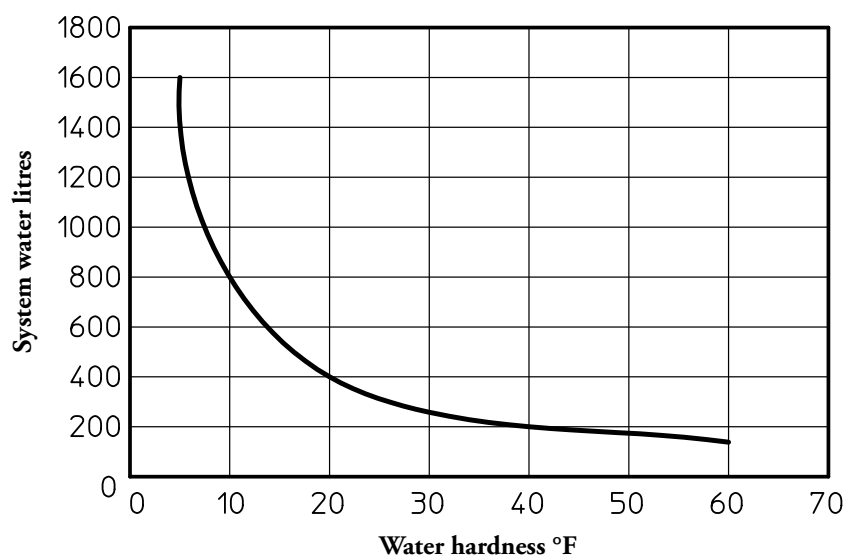

N.B.: the graph refers to the entire life cycle of the system. Therefore, also consider scheduled and unscheduled maintenance, which involves emptying and filling the said system.

VICTRIX MAIOR TT ErP

15

VICTRIX MAIOR 35 TT ErP WIRING DIAGRAM

ROOM THERMOSTAT OR REMOTE CONTROL

The boiler is prepared for the application of the remote control (CAR^{V2}), which must be connected to clamps 41 and 44 of the terminal board (positioned under the sealed chamber) respecting the polarity and eliminating jumper X40.

The boiler is prepared for the application of the Room Thermostat (S20) to be connected on clamps 40 and 41 of the low voltage terminal board (positioned under the sealed chamber),

eliminating jumper X40.

The external probe (B4) must be connected to clamps 38 and 39 always on the low voltage terminal board.

The boiler is also set-up for coupling with the System manager, for systems integrated with AUDAX, which must be connected to terminals 38 and 39 always on the low voltage terminal board (for operation at variable temperature use the external probe already present on AUDAX).

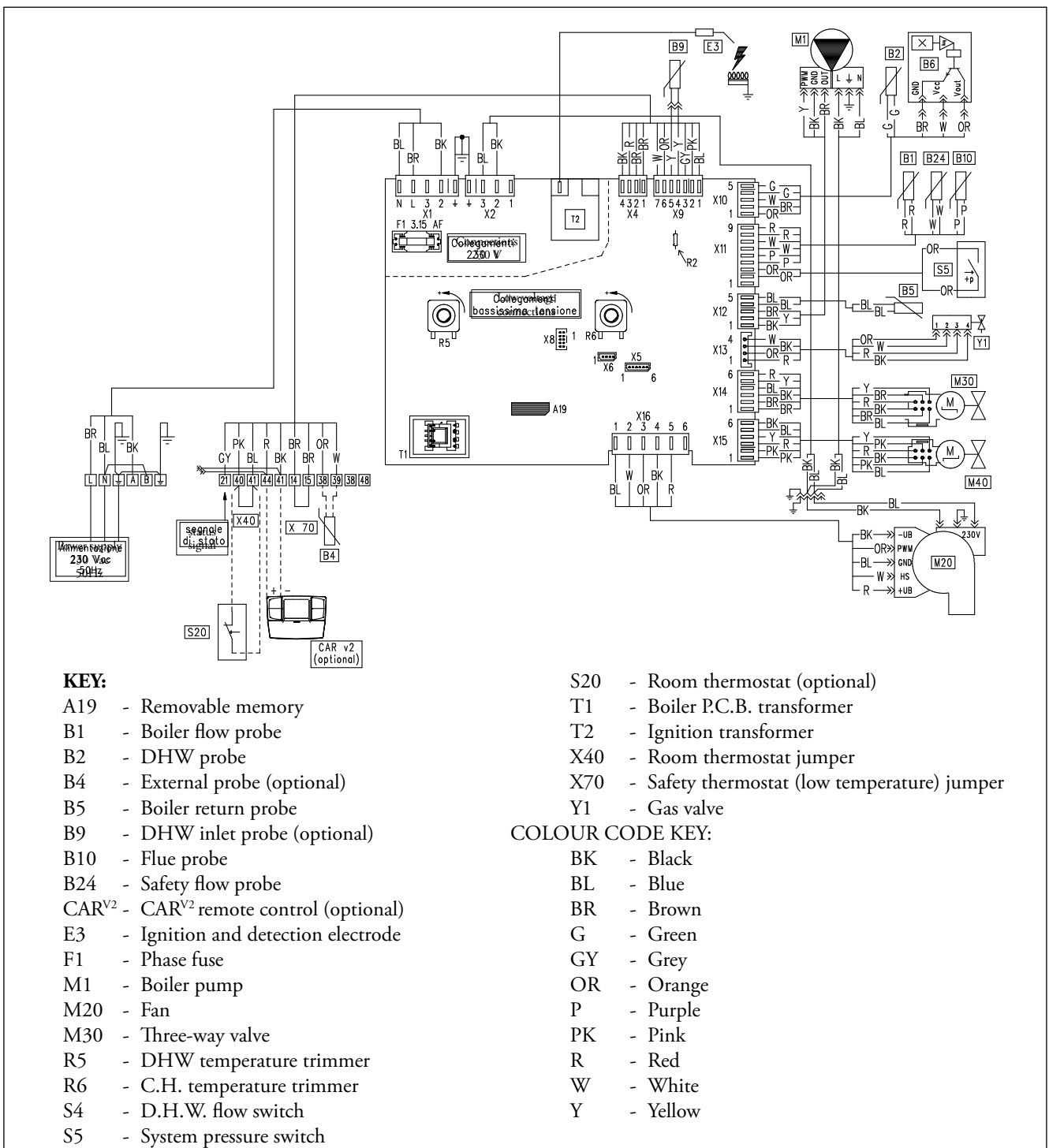

16 VICTRIX MAIOR 35 X TT ErP WIRING DIAGRAM

ROOM THERMOSTAT OR REMOTE CONTROL

The boiler is prepared for the application of the remote control (CAR^{V2}), which must be connected to clamps 41 and 44 of the terminal board (positioned under the sealed chamber) respecting the polarity and eliminating jumper X40.
 The boiler is prepared for the application of the Room Thermostat (S20) to be connected on clamps 40 and 41 of the low voltage terminal board (positioned under the sealed chamber),

eliminating jumper X40.

The external probe (B4) must be connected to clamps 38 and 39 always on the low voltage terminal board.

The boiler is also set-up for coupling with the System manager, for systems integrated with AUDAX, which must be connected to terminals 38 and 39 always on the low voltage terminal board (for operation at variable temperature use the external probe already present on AUDAX).

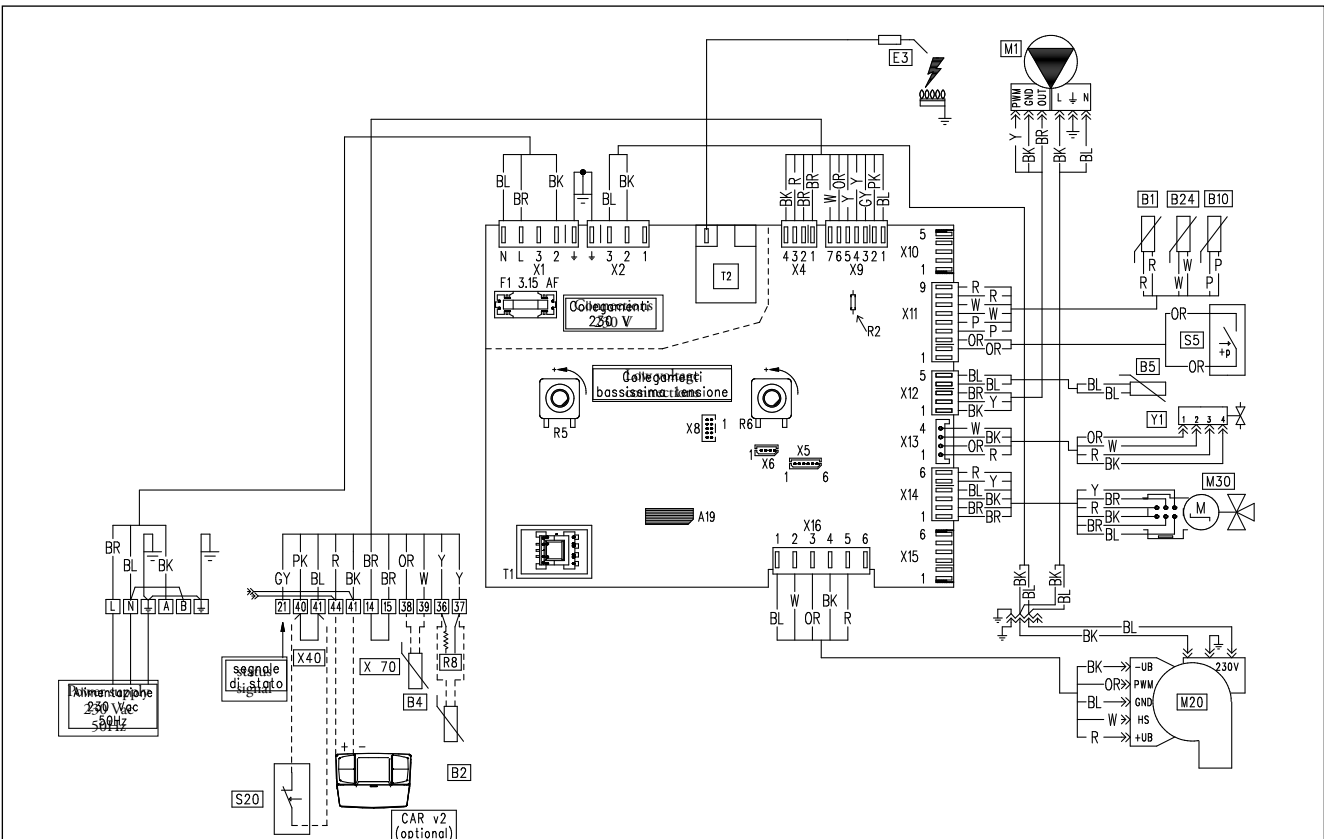

KEY:

- A19 - Removable memory
- B1 - Boiler flow probe
- B2 - Boiler probe (optional)
- B4 - External probe (optional)
- B5 - System return probe
- B10 - Flue probe
- B24 - Safety flow probe
- CAR^{V2} - CAR^{V2} remote control (optional)
- E3 - Ignition and detection electrode
- M1 - Boiler pump
- M20 - Fan
- M30 - Three-way valve
- R5 - DHW temperature trimmer
- R6 - C.H. temperature trimmer
- R8 - Storage tank operation unabling resistance
- S5 - System pressure switch
- S20 - Room thermostat (optional)

- T1 - Boiler P.C.B. transformer
- T2 - Ignition transformer
- X40 - Room thermostat jumper
- X70 - L.V. safety thermostat jumper
- Y1 - Gas valve

COLOUR CODE KEY:

- BK - Black
- BL - Blue
- BR - Brown
- G - Green
- GY - Grey
- OR - Orange
- P - Purple
- R - Red
- W - White
- Y - Yellow

VICTRIX MAIOR TT ErP

17

HYDRAULIC DIAGRAM VICTRIX MAIOR TT ErP

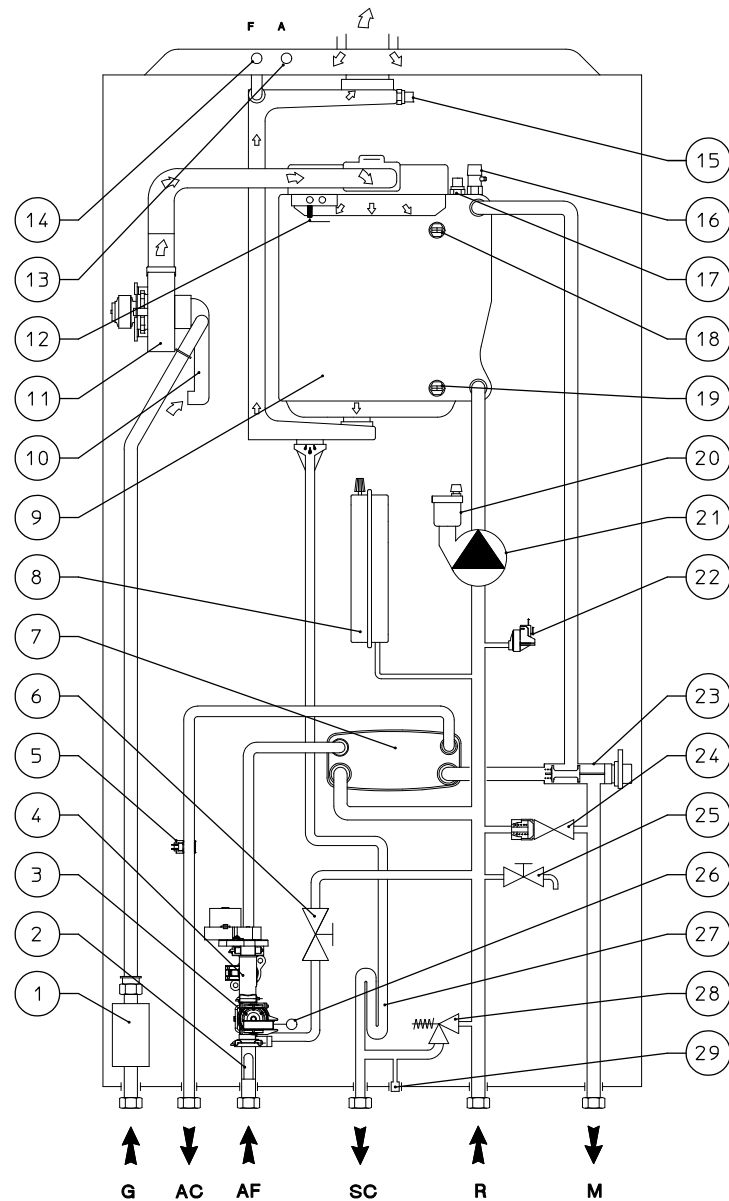

KEY:

- | | |
|-----------------------------------|--|
| 1 - Gas valve | 16 - Manual air vent valve |
| 2 - Water inlet filter | 17 - Flow probe |
| 3 - Domestic hot water flow meter | 18 - Safety flow probe |
| 4 - D.h.w. flow-rate regulator | 19 - Return probe |
| 5 - DHW probe | 20 - Air vent valve |
| 6 - System filling valve | 21 - Boiler pump |
| 7 - DHW heat exchanger | 22 - System pressure switch |
| 8 - System expansion vessel | 23 - 3-way valve (motorised) |
| 9 - Condensation module | 24 - By-pass |
| 10 - Air / gas mixer | 25 - System draining valve |
| 11 - Fan | 26 - DHW inlet probe trap |
| 12 - Ignition/detection electrode | 27 - Condensate drain trap |
| 13 - Air sample point | 28 - 3 bar safety valve |
| 14 - Flue sample point | 29 - 3 bar safety valve drain fitting signal |
| 15 - Flue probe | |

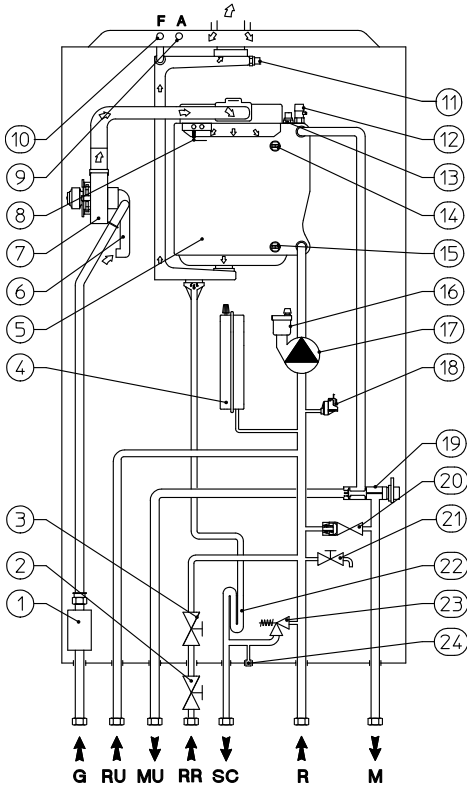

KEY:

- | | |
|----------------------------------|---|
| 1 - Gas valve | 22 - Condensate drain trap |
| 2 - Filling cut-off valve | 23 - 3 bar safety valve |
| 3 - System filling valve | 24 - 3 bar safety valve drain fitting signal |
| 4 - System expansion vessel | 25 - Storage tank unit draining valve |
| 5 - Condensation module | 26 - 8 bar safety valve |
| 6 - Air / gas mixer | 27 - Magnesium anode |
| 7 - Fan | 28 - D.H.W. expansion vessel |
| 8 - Ignition/detection electrode | 29 - Stainless steel coil for storage tank |
| 9 - Air sample point | 30 - One-way valve (OV 20) |
| 10 - Flue sample point | 31 - Cold water inlet filter |
| 11 - Flue probe | 32 - Cold water inlet cock |
| 12 - Manual air vent valve | 33 - DHW probe |
| 13 - Flow probe | 34 - Domestic inhibition probe (Optional) |
| 14 - Safety flow probe | 35 - Stainless steel coil that can be coupled to solar panels |
| 15 - Return probe | 36 - System draining valve |
| 16 - Air vent valve | 37 - Solar panels probe (Optional) |
| 17 - Boiler pump | |
| 18 - System pressure switch | |
| 19 - 3-way valve (motorised) | |
| 20 - By-pass | |
| 21 - System draining valve | |

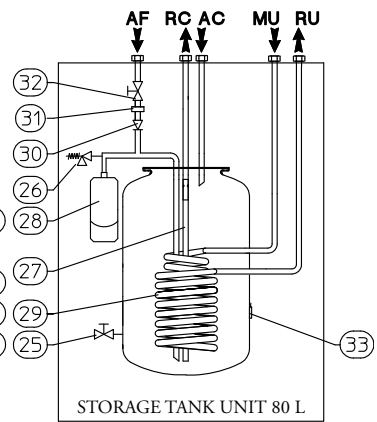
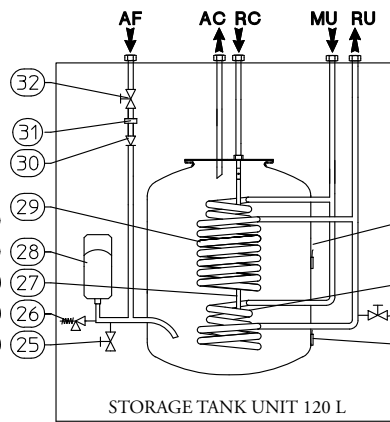
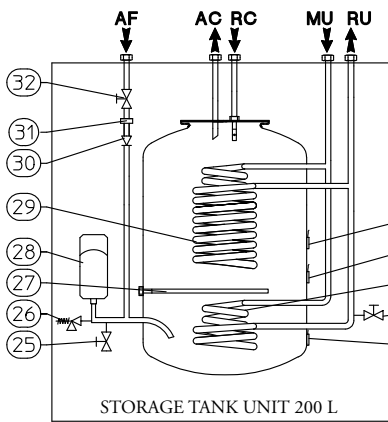

VICTRIX MAIOR X TT ErP

19 HYDRAULIC DIAGRAM VICTRIX MAIOR X TT ErP with UB INOX SOLAR 200 V2

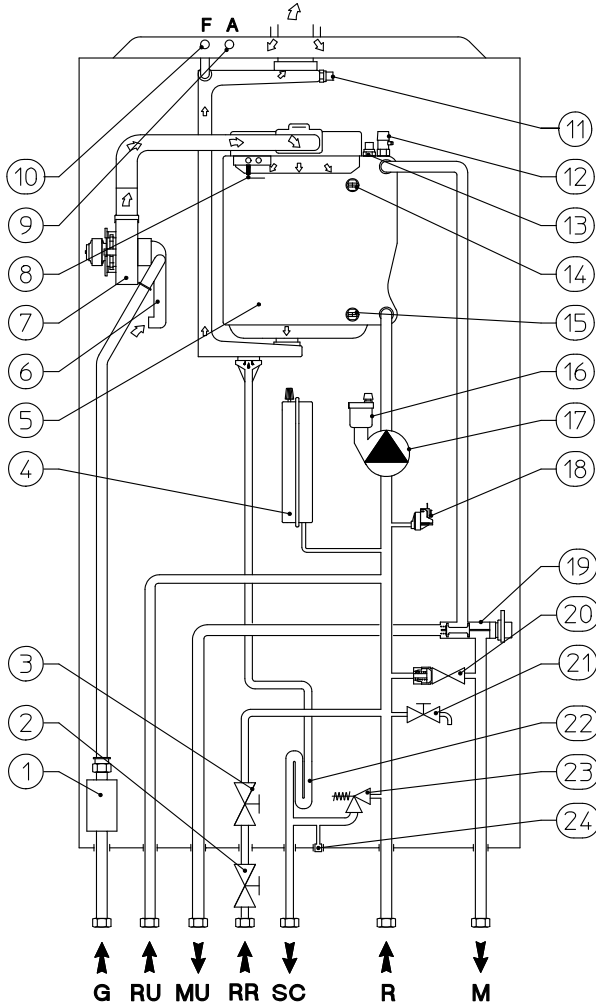

KEY:

- 1 - Gas valve
- 2 - Filling cut-off valve
- 3 - System filling valve
- 4 - System expansion vessel
- 5 - Condensation module
- 6 - Air / gas mixer
- 7 - Fan
- 8 - Ignition/detection electrode
- 9 - Air sample point
- 10 - Flue sample point
- 11 - Flue probe
- 12 - Manual air vent valve
- 13 - Flow probe
- 14 - Safety flow probe
- 15 - Return probe
- 16 - Air vent valve
- 17 - Boiler pump
- 18 - System pressure switch
- 19 - 3-way valve (motorised)
- 20 - By-pass
- 21 - System draining valve
- 22 - Condensate drain trap
- 23 - 3 bar safety valve
- 24 - 3 bar safety valve drain fitting signal
- 25 - Storage tank draining valve
- 26 - 8 bar safety valve
- 27 - Magnesium anode
- 28 - Domestic hot water expansion vessel
- 29 - Stainless steel coil for storage tank
- 30 - System draining valve
- 31 - DHW circuit mixing valve
- 32 - Mixing valve filter
- 33 - One-way valve (OV 20)
- 34 - Cold water inlet filter
- 35 - One-way valve (OV 15) (Optional)
- 36 - Cold water inlet cock
- 37 - One-way solar valve
- 38 - 6 bar safety valve
- 39 - Shut-off valve with thermometer
- 40 - Solar expansion vessel
- 41 - Solar circulator pump
- 42 - Flow meter
- 43 - DHW probe
- 44 - Domestic hot water unabling probe
- 45 - Stainless steel coil that can be coupled to solar panels
- 46 - Solar system draining valve
- 47 - Solar panels probe

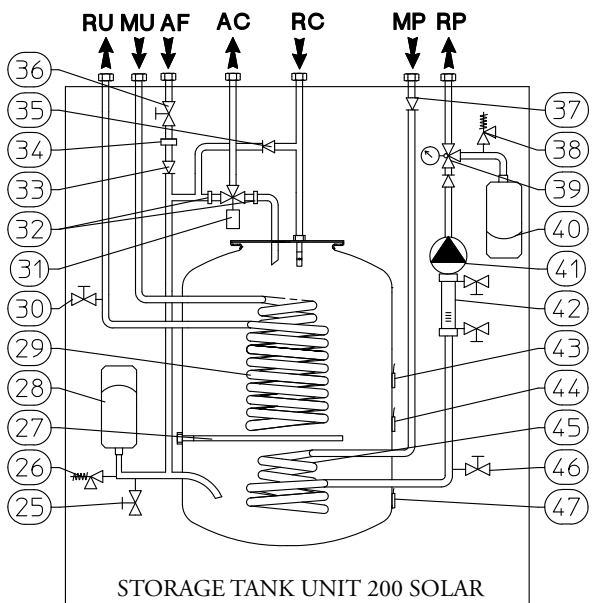

STORAGE TANK UNIT 200 SOLAR

Domestic hot water maximum heating power		kW (kcal/h)	29.1 (25,057)
Central heating maximum heat input		kW (kcal/h)	24.9 (21,373)
DHW maximum useful heat output		kW (kcal/h)	28.0 (24,080)
CH maximum useful heat output		kW (kcal/h)	24.0 (20,640)
Minimum nominal heat input		kW (kcal/h)	2.9 (2,477)
Minimum nominal heat output		kW (kcal/h)	2.8 (2,408)
Efficiency at 100% Pn (80/60°C)		%	96.6
Efficiency at 30% of the load (80/60°C)		%	102.5
Efficiency at 100% Pn (50/30°C)		%	101.0
Efficiency at 30% of the load (50/30°C)		%	108.3
Efficiency at 100% Pn (40/30°C)		%	102.3
Efficiency at 30% of the load (40/30°C)		%	108.3
Central heating circuit			
Adjustable central heating temperature (min. / max)		°C	min. 20 - 50 / max 85
System max. working temperature		°C	90
System max. working pressure		bar	3
System expansion vessel nominal/(real) capacity		litres	10 / (7.1)
System expansion vessel factory-set pressure		bar	1.0
Head available with 1000 l/h flow rate		kPa (m H ₂ O)	37.2 (3.79)
DHW circuit			
Hot water production useful heat output		kW (kcal/h)	28.0 (24,080)
DHW adjustable temperature		°C	30 - 60
Domestic hot water circuit min. dynamic pressure		bar	0.3
Domestic hot water circuit max. pressure		bar	10
D.H.W. min. withdrawal		litres/min	1.5
Flow rate in continuous service (ΔT 30°C)		litres/min	13.3
Gas supply			
Gas flow rate at burner (G20)	MIN - MAX	m ³ /h	0.30 - 2.63 (3.08 DHW)
Gas flow rate at burner (G31)	MIN - MAX	kg/h	0.22 - 1.93 (2.26 DHW)
Electric power supply		V/Hz	230 - 50
Nominal power absorption		A	0.70
Installed electric power		W	100
Fan absorbed power		W	36
Power absorbed by pump max speed		W	59
Power absorbed in stand-by		W	6.0
Electric insulation rating	IP		X5D
Boiler water content		litres	1.9
Weight of empty boiler		kg	32.0

VICTRIX MAIOR TT ErP

20.1

VICTRIX MAIOR 35 TT 1 ErP TECHNICAL DATA

Maximum nominal heat input		kW (kcal/h)	34.9 (30,040)
Maximum useful heat output		kW (kcal/h)	34.2 (29,412)
Minimum nominal heat input		kW (kcal/h)	3.6 (3,109)
Minimum nominal heat output		kW (kcal/h)	3.5 (3,010)
Efficiency at 100% Pn (80/60°C)		%	97.9
Efficiency at 30% of the load (80/60°C)		%	103.2
Efficiency at 100% Pn (50/30°C)		%	103.4
Efficiency at 30% of the load (50/30°C)		%	108.5
Efficiency at 100% Pn (40/30°C)		%	106.0
Efficiency at 30% of the load (40/30°C)		%	108.5
Central heating circuit			
Adjustable central heating temperature (min. / max)		°C	min. 20 - 50 / max 85
System max. working temperature		°C	90
System max. working pressure		bar	3
System expansion vessel nominal/(real) capacity		litres	10 / (7.1)
System expansion vessel factory-set pressure		bar	1.0
Head available with 1000 l/h flow rate		kPa (m H ₂ O)	37.2 (3.8)
DHW circuit			
Hot water production useful heat output		kW (kcal/h)	34.2 (29,412)
DHW adjustable temperature		°C	30 - 60
Domestic hot water circuit min. dynamic pressure		bar	0.3
Domestic hot water circuit max. pressure		bar	10
D.H.W. min. withdrawal		litres/min	1.5
Flow rate in continuous service (ΔT 30°C)		litres/min	16.8
Gas supply			
Gas flow rate at burner (G20)	MIN - MAX	m ³ /h	0.38 - 3.70
Gas flow rate at burner (G31)	MIN - MAX	kg/h	0.28 - 2.71
Electric power supply		V/Hz	230 - 50
Nominal power absorption		A	0.85
Installed electric power		W	120
Fan absorbed power		W	45
Power absorbed by pump max speed		W	59
Power absorbed in stand-by		W	6.0
Electric insulation rating	IP		X5D
Boiler water content		litres	2.4
Weight of empty boiler		kg	33.4

Maximum nominal heat input		kW (kcal/h)	34.9 (30,040)
Maximum useful heat output		kW (kcal/h)	34.2 (29,412)
Minimum nominal heat input		kW (kcal/h)	3.6 (3,109)
Minimum nominal heat output		kW (kcal/h)	3.5 (3,010)
Efficiency at 100% Pn (80/60°C)		%	97.9
Efficiency at 30% of the load (80/60°C)		%	103.2
Efficiency at 100% Pn (50/30°C)		%	103.2
Efficiency at 30% of the load (50/30°C)		%	108.5
Efficiency at 100% Pn (40/30°C)		%	106.0
Efficiency at 30% of the load (40/30°C)		%	108.5
Central heating circuit			
Adjustable central heating temperature (min. / max.)		°C	Min. 20 - 50 / Max. 85
System max. working temperature		°C	90
System max. working pressure		bar	3
System expansion vessel nominal/(real) capacity		litres	10 / (7.1)
System expansion vessel factory-set pressure		bar	1.0
Head available with 1000 l/h flow rate		kPa (m c.a.)	37.2 (3.8)
DHW circuit			
Hot water production useful heat output		kW (kcal/h)	34.2 (29,412)
DHW adjustable temperature		°C	10 - 60
DHW Circuit max. pressure		bar	10
Specific flow rate x 10 min. (Δt 30°C) U.B. 80-2		litres/min	23.3
Specific flow rate x 10 min. (Δt 30°C) U.B. 120-2		litres/min	28.4
Specific flow rate x 10 min. (Δt 30°C) U.B. 200-2		litres/min	39.7
Flow rate in continuous service (ΔT 30°C)		litres/min	16.3
DHW expansion vessel capacity		litres	4,0 (UB 80 V2) / 5 (UB 120 V2) 8 (UB 200 V2)
DHW expansion vessel factory-set pressure		bar	2.5 (for all Storage tank units)
Gas supply			
Gas flow rate at burner (G20)	MIN - MAX	m ³ /h	0.38 - 3.70
Gas flow rate at burner (G31)	MIN - MAX	kg/h	0.28 - 2.71
Electric power supply		V/Hz	230 - 50
Nominal power absorption		A	0.85
Installed electric power		W	120
Fan absorbed power		W	45
Power absorbed by pump max speed		W	59
Power absorbed in stand-by		W	6
Electric insulation rating	IP		X5D
Boiler water content		litres	2.4
Weight of empty boiler		kg	33.4

VICTRIX MAIOR TT ErP

22
COMBUSTION FEATURES VICTRIX MAIOR 28 TT 1 ErP

		(G20)	(G31)
Combustion efficiency 100% Pn (80/60°C)	%	98.0	98.0
Combustion efficiency P min (80/60°C)	%	98.5	98.5
Effective efficiency at 100% Pn (80/60°C)	%	96.1	96.1
Effective efficiency P min (80/60°C)	%	97.2	97.2
Effective efficiency at 100% Pn (50/30°C)	%	99.2	99.2
Effective efficiency P min (50/30°C)	%	107.3	107.3
Effective efficiency at 100% Pn (40/30°C)	%	100.2	100.2
Effective efficiency P min (40/30°C)	%	108.1	108.1
Chimney losses with burner on (100% Pn) (80/60°C)	%	2.0	2.0
Chimney losses with burner on (P min) (80/60°C)	%	1.5	1.5
Chimney losses with burner off	%	0.01	0.01
Casing losses with burner on (100% Pn) (80/60°C)	%	1.9	1.9
Casing losses with burner off	%	0.40	0.40
Flue gas temperature Maximum Heat Input	°C	51	52
Flue gas temperature Minimum Heat Input	°C	45	45
Flue flow rate at Central Heating Maximum Heat Input	kg/h	40	40
Flue flow rate at Maximum Domestic Hot Water Heat Input	kg/h	46	47
Flue flow rate at Minimum Heat Input	kg/h	5	5
CO ₂ at the Maximum Central Heating Heat Input	%	9.35	10.50
CO ₂ at Maximum Domestic Hot Water Heat Input	%	9.55	10.55
CO ₂ at Minimum Heat Input	%	9.10	10.10
CO at Maximum Heat Input	mg/kWh	144	235
CO at Minimum Heat Input	mg/kWh	11	14
NO _x at the Maximum Heat Input	mg/kWh	41	39
NO _x at Minimum Heat Input	mg/kWh	19	25
Weighted CO	mg/kWh	29	-
Weighted NO _x	mg/kWh	25	-
NO _x class	-	6	6
Intake / exhaust available head (Min. - Max.)	Pa	2 - 203	

Gas flow rates refer to the NHV at the temperature of 15° C and pressure of 1013 mbar.

Flue temperature values refer to an air inlet temperature of 15°C and flow/return temperature = 80/60°C.

22.1 COMBUSTION FEATURES VICTRIX MAIOR 35 TT 1 ErP - 35 X TT 1 ErP

		(G20)	(G31)
Combustion efficiency 100% Pn (80/60°C)	%	98.0	98.0
Combustion efficiency P min (80/60°C)	%	98.4	98.4
Effective efficiency at 100% Pn (80/60°C)	%	97.9	97.9
Effective efficiency P min (80/60°C)	%	96.8	96.8
Effective efficiency at 100% Pn (50/30°C)	%	103.4	103.4
Effective efficiency P min (50/30°C)	%	107.5	107.5
Effective efficiency at 100% Pn (40/30°C)	%	106.0	106.0
Effective efficiency P min (40/30°C)	%	107.6	107.6
Chimney losses with burner on (100% Pn) (80/60°C)	%	2.0	2.0
Chimney losses with burner on (P min) (80/60°C)	%	1.6	1.6
Chimney losses with burner off	%	0.01	0.01
Casing losses with burner on (100% Pn) (80/60°C)	%	0.1	0.1
Casing losses with burner off	%	0.35	0.35
Flue gas temperature Maximum Heat Input	°C	56	56
Flue gas temperature Minimum Heat Input	°C	47	47
Flue gas flow rate at Maximum Heat Input	kg/h	55	56
Flue flow rate at Minimum Heat Input	kg/h	6	6
CO ₂ at Maximum Heat Input	%	9.50	10.50
CO ₂ at Minimum Heat Input	%	9.00	10.00
CO at Maximum Heat Input	mg/kWh	143	151
CO at Minimum Heat Input	mg/kWh	5	5
NO _x at the Maximum Heat Input	mg/kWh	34	30
NO _x at Minimum Heat Input	mg/kWh	21	24
Weighted CO	mg/kWh	24	-
Weighted NO _x	mg/kWh	26	-
NO _x class	-	6	6
Intake / exhaust available head (Min. - Max.)	Pa	2 - 258	

Gas flow rates refer to the NHV at the temperature of 15° C and pressure of 1013 mbar.

Flue temperature values refer to an air inlet temperature of 15°C and flow/return temperature = 80/60°C.

VICTRIX MAIOR TT ErP

23

PRODUCT FICHE (REGULATION 811/2013)

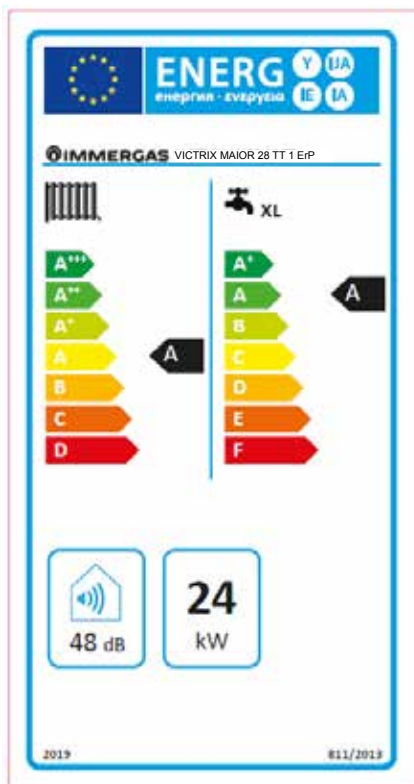

VICTRIX MAIOR 28 TT 1 ErP

Parameter	value
Annual energy consumption for the central heating mode (Q_{HE})	41.7 GJ
Annual electricity consumption for the domestic hot water function (AEC)	49 kWh
Annual fuel consumption for the domestic hot water function (AFC)	17 GJ
Room central heating seasonal efficiency (η_s)	93 %
Water heating energy efficiency (η_{wh})	85 %

23.1 TECHNICAL PARAMETERS FOR COMBINATION BOILERS (REGULATION 813/2013)

Efficiencies in the following tables refer to the gross calorific value.

Model/s:				VICTRIX MAIOR 28 TT 1 ErP					
Condensing Boilers:				YES					
Low temperature boiler:				NO					
Boiler type B1:				NO					
Co-generation appliance for central heating:				NO		Fitted with supplementary heating system:		NO	
Mixed heating appliance:				YES					
Element	Symbol	Value	Unit	Element	Symbol	Value	Unit		
Nominal heat output	P_n	24	kW	Seasonal energy efficiency of central heating	η_s	93	%		
For heating only boilers and combination boilers: useful heat output				For central heating only and combination boilers: effective efficiency					
At nominal heat output in high temperature mode (*)	P_4	24.0	kW	At nominal heat output in high temperature mode (*)	η_4	87.6	%		
At 30% of nominal heat output in a low temperature mode (**)	P_1	8.1	kW	At 30% of nominal heat output in a low temperature mode (**)	η_1	97.6	%		
Auxiliary electricity consumption				Other items					
At full load	el_{max}	0.018	kW	Heat loss in standby	P_{stby}	0.045	kW		
At partial load	el_{min}	0.013	kW	Ignition burner energy consumption	P_{ign}	0.000	kW		
In standby mode	P_{SB}	0.005	kW	Emissions of nitrogen oxides	NO_x	23	mg / kWh		
For combination central heating appliances									
Stated load profile	XL			Domestic hot water production efficiency	η_{WH}	85	%		
Daily electrical power consumption	Q_{elec}	0.225	kWh	Daily gas consumption	Q_{fuel}	22.875	kWh		
Contact information	IMMERGAS S.p.A. VIA CISA LIGURE, 95 - 42041 BRESCELLO (RE) ITALY								
(*) High temperature mode means 60°C on return and 80°C on flow.									
(**) Low temperature mode for condensation Boilers means 30°C, for low temperature boilers 37°C and for other appliances 50°C of return temperature.									

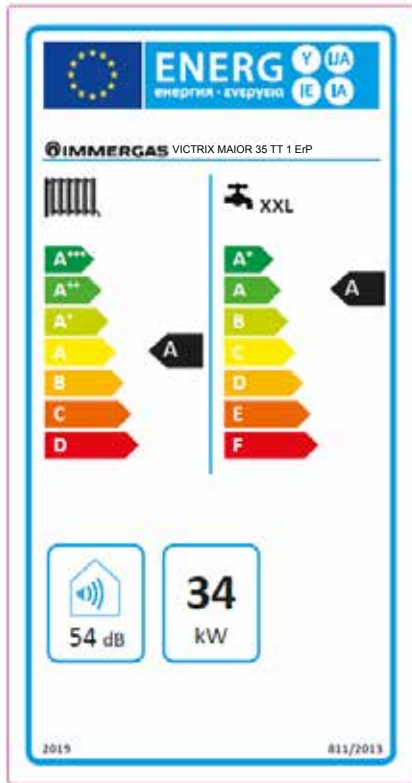

VICTRIX MAIOR 35 TT 1 ErP

Parameter	value
Annual energy consumption for the central heating mode (Q_{HE})	58.4 GJ
Annual electricity consumption for the domestic hot water function (AEC)	49 kWh
Annual fuel consumption for the domestic hot water function (AFC)	22 GJ
Room central heating seasonal efficiency (η_s)	93 %
Water heating energy efficiency (η_{wh})	85 %

24.1 TECHNICAL PARAMETERS FOR COMBINATION BOILERS (REGULATION 813/2013)

Efficiencies in the following tables refer to the gross calorific value.

Model/s:				VICTRIX MAIOR 35 TT 1 ErP				
Condensing Boilers:				YES				
Low temperature boiler:				NO				
Boiler type B1:				NO				
Co-generation appliance for central heating:				NO		Fitted with supplementary heating system:		NO
Mixed heating appliance:				YES				
Element	Symbol	Value	Unit	Element	Symbol	Value	Unit	
Nominal heat output	P_n	34	kW	Seasonal energy efficiency of central heating	η_s	93	%	
For heating only boilers and combination boilers: useful heat output				For central heating only and combination boilers: effective efficiency				
At nominal heat output in high temperature mode (*)	P_4	34.2	kW	At nominal heat output in high temperature mode (*)	η_4	88.2	%	
At 30% of nominal heat output in a low temperature mode (**)	P_1	11.4	kW	At 30% of nominal heat output in a low temperature mode (**)	η_1	97.7	%	
Auxiliary electricity consumption				Other items				
At full load	el_{max}	0.020	kW	Heat loss in standby	P_{stby}	0.051	kW	
At partial load	el_{min}	0.012	kW	Ignition burner energy consumption	P_{ign}	0.000	kW	
In standby mode	P_{SB}	0.004	kW	Emissions of nitrogen oxides	NO_x	24	mg / kWh	
For combination central heating appliances								
Stated load profile	XXL			Domestic hot water production efficiency	η_{WH}	85	%	
Daily electrical power consumption	Q_{elec}	0.222	kWh	Daily gas consumption	Q_{fuel}	28.449	kWh	
Contact information	IMMERGAS S.p.A. VIA CISA LIGURE, 95 - 42041 BRESCELLO (RE) ITALY							
(*) High temperature mode means 60°C on return and 80°C on flow.								
(**) Low temperature mode for condensation Boilers means 30°C , for low temperature boilers 37°C and for other appliances 50°C of return temperature.								

VICTRIX MAIOR X TT ErP

25

PRODUCT FICHE (REGULATION 811/2013)

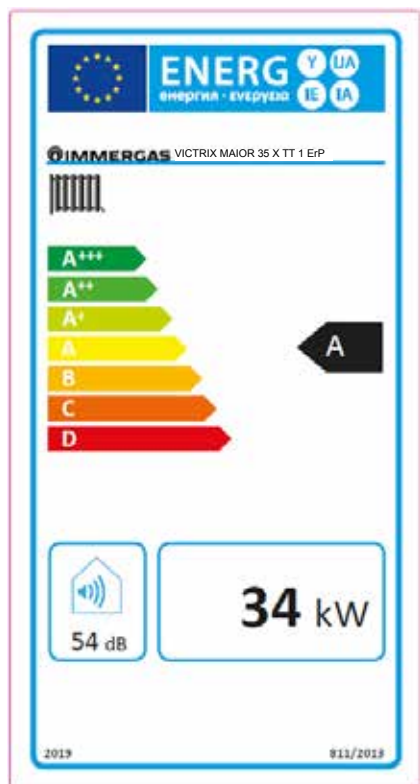





VICTRIX MAIOR 35 X TT 1 ErP

Parameter	value
Annual energy consumption for the central heating mode (Q_{HE})	58.4 GJ
Annual electricity consumption for the domestic hot water function (AEC)	
Annual fuel consumption for the domestic hot water function (AFC)	
Room central heating seasonal efficiency (η_s)	93 %
Water heating energy efficiency (η_{wh})	

25.1 TECHNICAL PARAMETERS FOR COMBINATION BOILERS (REGULATION 813/2013)

Efficiencies in the following tables refer to the gross calorific value.

Model/s:				VICTRIX MAIOR 35 X TT 1 ErP					
Condensing Boilers:				YES					
Low temperature boiler:				NO					
Boiler type B1:				NO					
Co-generation appliance for central heating:				NO		Fitted with supplementary heating system:		NO	
Mixed heating appliance:				YES					
Element	Symbol	Value	Unit	Element	Symbol	Value	Unit		
Nominal heat output	P_n	34	kW	Seasonal energy efficiency of central heating	η_s	93	%		
For heating only boilers and combination boilers: useful heat output				For central heating only and combination boilers: effective efficiency					
At nominal heat output in high temperature mode (*)	P_4	34.2	kW	At nominal heat output in high temperature mode (*)	η_4	88.2	%		
At 30% of nominal heat output in a low temperature mode (**)	P_1	11.4	kW	At 30% of nominal heat output in a low temperature mode (**)	η_1	97.7	%		
Auxiliary electricity consumption				Other items					
At full load	$e_{l_{max}}$	0.020	kW	Heat loss in standby	P_{stby}	0.051	kW		
At partial load	$e_{l_{min}}$	0.012	kW	Ignition burner energy consumption	P_{ign}	0.000	kW		
In standby mode	P_{SB}	0.004	kW	Emissions of nitrogen oxides	NO_x	24	mg / kWh		
For combination central heating appliances									
Stated load profile				Domestic hot water production efficiency		η_{WH}	%		
Daily electrical power consumption				Q_{elec}	Daily gas consumption		Q_{fuel}	kWh	
Contact information				IMMERGAS S.p.A. VIA CISA LIGURE, 95 - 42041 BRESCELLO (RE) ITALY					
(*) High temperature mode means 60°C on return and 80°C on flow.									
(**) Low temperature mode for condensation Boilers means 30°C, for low temperature boilers 37°C and for other appliances 50°C of return temperature.									

<p>CAR^{V2} product class V* or VI code 3.021395</p> 	<p>CAR^{V2} WIRELESS product class V* or VI code 3.021623</p> 
<p>CRONO 7 product class IV* or VII code 3.021622</p> 	<p>CRONO 7 WIRELESS product class IV* or VII code 3.021624</p> 
<p>External probe product class II* or VI or VII code 3.014083</p> 	

NOTE: Some thermoregulation product can have different classes.
For example the CAR^{V2} belongs by default to class "V", also adding the External probe the heat adjustment class becomes "VI".

* Product whit default setting.

REF. European Commission Notice 2014/C 207/02



6.2. Contribution to temperature controls of seasonal space heating energy efficiency of packages of space heaters, temperature control and solar devices or of packages of combination heaters, temperature control and solar devices

Class No.	I	II	III	IV	V	VI	VII	VIII
% Value	1	2	1.5	2	3	4	3.5	5

VICTRIX MAIOR TT ErP

27

OTHER OPTIONAL VICTRIX MAIOR TT ErP

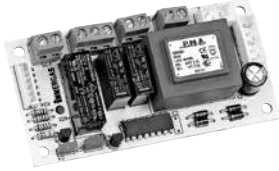
<p>Telephonic remote control code 3.013305</p> 	<p>GSM telephonic control code 3.017182</p> 
<p>Control box for pumps and zone kit code 3.011668</p> 	<p>Relay board kit code 3.015350</p> 
<p>Multi-zone electronic board kit code 3.028444</p>	<p>Mixing valve for multi-zone electronic board kit code 3.027084</p>
<p>Condensate discharge compact pump kit code 3.026374</p>	<p>Condensate neutralizer kit for single installation kit code 3.019857</p>
<p>Anti-freeze protection (-15°C) kit code 3.017324</p>	<p>Top cover kit code 3.024608</p>
<p>Anti-scale kit (indoor only) code 3.017323</p>	<p>Safety thermostat kit code 3.019229</p>
<p>Magnetic cyclone filter kit code 3.024176</p>	<p>Additional 2 litres expansion vessel code 3.017514</p>
<p>All-purpose connection kit code 3.011667</p>	<p>Shut off knobs kit code 3.5324</p>
<p>Shut off knobs with filters kit code 3.015854</p>	<p>DOMINUS Interface kit code 3.026273</p>
<p>Bottom cover kit for condensing boilers code 3.027341</p>	<p>Non return valve kit code 3.016301</p>

The boiler is designed to be combined with DIM (Multi-system Distribution Manifold), available in recess or wall-hung versions, to manage homogeneous or mixed zone systems.

28

OTHER OPTIONAL VICTRIX MAIOR X TT ErP

Telephonic remote control code 3.013305	GSM telephonic control code 3.017182
Control box for pumps and zone kit code 3.011668	Relay board kit code 3.015350
Multi-zone electronic board kit code 3.028444	Mixing valve for multi-zone electronic board kit code 3.027084
Condensate discharge compact pump kit code 3.026374	Condensate neutralizer kit for single installation kit code 3.019857
Anti-freeze protection (-15°C) kit code 3.017324	Top cover kit code 3.024608
DOMINUS Interface kit code 3.026273	Magnetic cyclone filter kit code 3.024176
All-purpose connection kit code 3.011667	Safety thermostat kit code 3.019229
Shut off knobs with filters kit code 3.015854	Shut off knobs kit code 3.5324
Additional 2 litres expansion vessel code 3.017514	Bottom cover kit for condensing boilers code 3.027341
Storage tank connection kit code 3.024609	Disconnecter kit code 3.016301
STORAGE TANK OPTIONAL	
UB INOX 80 V2 recirculation kit code 3.022198	UB INOX 120 V2 recirculation kit code 3.022199
UB INOX 200 V2 and UB INOX SOLAR 200 V2 recirculation kit code 3.022200	Recirculation connection kit for two UB INOX 120 V2 or two UB INOX 200 V2 in parallel code 3.022201
Solar panels connection kit UB INOX 120 V2 code 3.022197	Solar panels connection kit UB INOX 200 V2 code 3.022195
Solar panels connection kit for two UB INOX 120 V2 or two UB INOX 200 V2 in parallel code 3.022196	Connection kit for two UB INOX 120 V2 or two UB INOX 200 V2 in parallel code 3.022212
Solar control unit kit for UB INOX 120 V2 and UB INOX 200 V2 code 3.019097	Column attachment kit for UB INOX 120 V2 and UB INOX 200 V2 code 3.017325

The boiler is designed to be combined with DIM (Multi-system Distribution Manifold), available in recess or wall-hung versions, to manage homogeneous or mixed zone systems.

VICTRIX MAIOR X TT ErP

29

STORAGE TANKS PRODUCT FICHE (REGULATION 812/2013)

UB INOX 80 V2

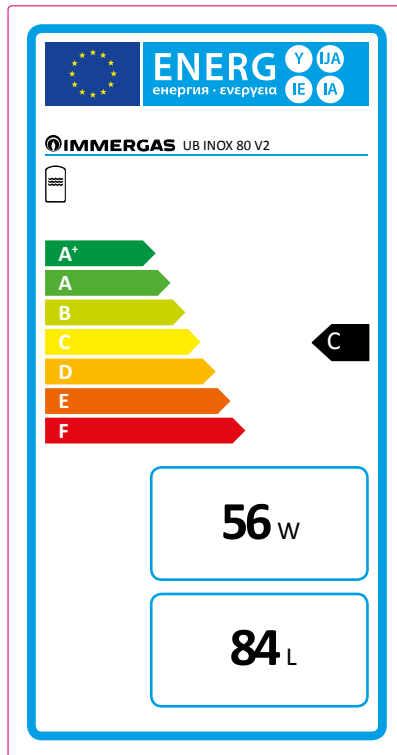

UB INOX 120 V2

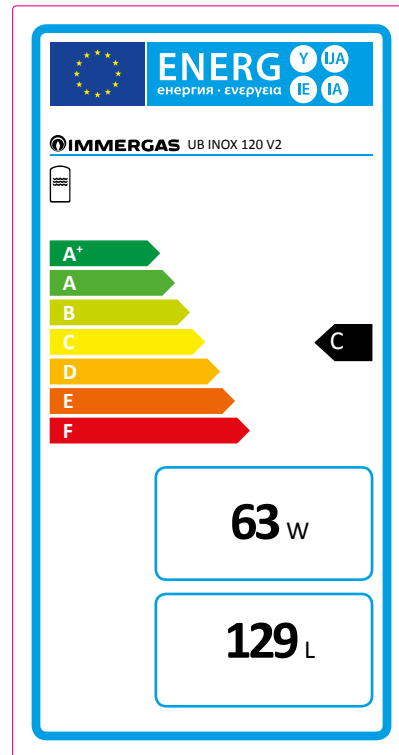

UB INOX 200 V2

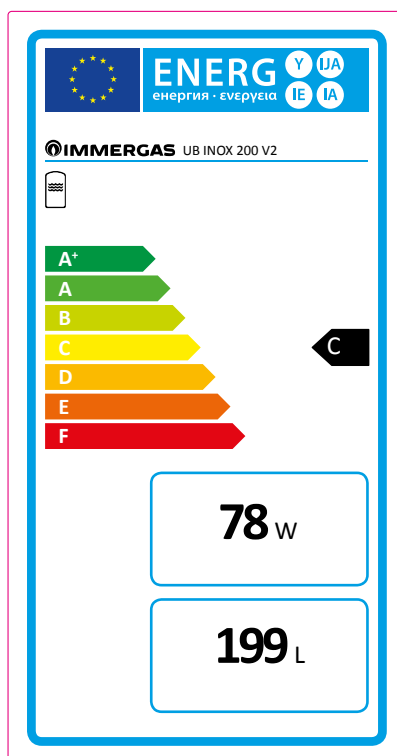

UB INOX SOLAR 200 V2

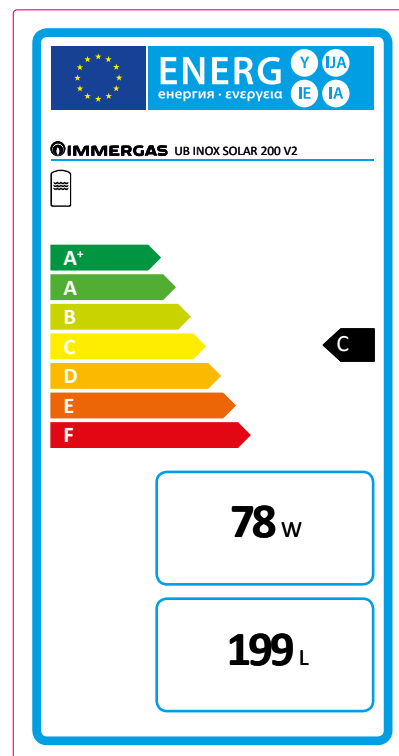

CERTIFICATE



Number KIP-15928/G Scope Regulation (EU) 2016/426
Issue date 09-05-2018 Module B
Expire date 08-05-2028
PIN 0476CT2750 Report 2002750
Replaces — Page 1 of 1

EU TYPE-EXAMINATION CERTIFICATE

Kiwa Cermet Italia declares that the products type:

Central heating condensing boilers

Trade mark: **Immergas**

Models: VICTRIX MAIOR 28 TT 1 ErP,
VICTRIX MAIOR 35 TT 1 ErP,
VICTRIX MAIOR 35 X TT 1 ErP,

Placed on the market by **Immergas S.p.A.**
Via Cisa Ligure, 95,
42041 Brescello (RE), Italy

meet the essential requirements as described in the

Regulation (EU) 2016/426 relating to appliances burning gaseous fuels.

Appliance type: B_{23P}, B₃₃, B₅₃, C₁₃, C_{13x}, C₃₃, C_{33x}, C₄₃, C_{43x}, C₅₃, C₆₃, C_{83x}, C₈₃, C₉₃, C_{93x}

Countries: AL, AT, BE, BG, CH, CY, CZ, DE, DK, EE, ES, FI, FR, GB, GR, HR, HU, IE, IS, LT, LU, LV, MK, MT, NO, NL, PL, PT, RO, SE, SI, SK, TR

Related to the following gas groups:

Group	mbar
E	20
H	20
Esi	20/25

Group	mbar
Er	20/25
E(S)	20
E(R)	20

Group	mbar
Lw	20
Ls	13
M	20

Group	mbar
P	30; 37; 50

The above gas groups can be combined according to the standard EN437:2009 and national situation of countries.

The assessment test have been performed using the following standards as guidelines:

EN 15502-1:2012+A1:2015, EN 15502-2-1:2012+A1:2016

The validity of this certificate can be verified on request at the following e-mail address: info@kiwa.it

This certificate will expire if there have been any changes to the product that may have an impact on compliance with the requirements of the Directive. This certificate will expire if there have been any updates and / or changes to the Technical Standards applicable unless specifically approved by Kiwa Cermet Italia.

Chief Operating Officer
Giampiero Bekredi

Kiwa Cermet Italia S.p.A.
Società con socio unico, soggetta all'attività di direzione e coordinamento di Kiwa Italia Holding Srl

Via Cadriano, 23
40057 Granarolo dell'Emilia (BO)

Unità locale
Via Treviso 32/34
31020 San Vendemiano (TV)

Tel +39. 0438 411755
Fax +39.0438 22428

E-mail: info@kiwacermet.it

www.kiwa.it
www.kiwacermet.it

GASTEC



SGQ N° 007A
SGA N° 010D
PRD N° 069B
FSM N° 004I
PRS N° 089C



Organismo Notificato n. 0476

During the useful life of the products, performance is affected by external factors, e.g. the hardness of the DHW, atmospheric agents, deposits in the system and so on.

The declared data refer to new products that are correctly installed and used in observance of the Standards in force.

N.B.: correct periodic maintenance is highly recommended.

NOTE: Depending on the specific design and installation conditions, the diagrams and drawings provided in this documentation can require further integration or modifications, according to what is set forth by the Standards and technical regulations in force and applicable (as an example, the R stamp - edition 2009 is mentioned). It is the professional's responsibility to identify the applicable provisions, to evaluate compliance with these in each case and the necessity of any changes to diagrams and drawings.



Immergas TOOLBOX

The App designed by Immergas for professionals



immergas.com

To request further specific details, sector Professionals can also use the following e-mail address:

consulenza@immergas.com

Immergas S.p.A.
42041 Brescello (RE) - Italy
Tel. 0522.689011
Fax 0522.680617



IMMERGAS
UNI EN ISO 9001:2008
CERTIFIED QUALITY
SYSTEM

Design, manufacture and after-sales assistance of gas boilers, gas water heaters and relative accessories

